

Biscay II electric shower

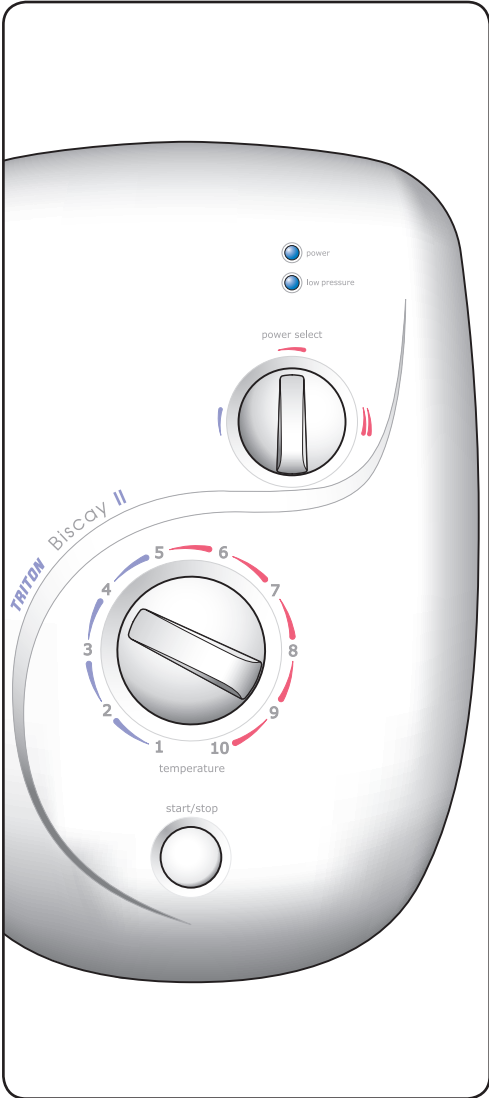

Installation and operating instructions



INSTALLERS PLEASE NOTE THESE INSTRUCTIONS ARE TO BE LEFT WITH THE USER

CONTENTS	Page
Important safety information	1
Introduction	2
Specifications	2
Advice to users	2
Main components	3
Electrical requirements	4
Water requirements	6
Siting of the shower	7
Fitting the shower to the wall	8
Plumbing connections	10
Electrical connections	11
Replacing the cover	12
Commissioning	13
Operating the shower	14
Operating functions	16
Fitting the riser rail	17
Fitting the hose and showerhead	18
Adjusting the showerhead	19
Cleaning the showerhead	20
Cleaning the inlet filter	21
Fault finding	24
Guarantee, service policy, etc.	26

To check the product suitability for commercial and multiple installations, please contact Triton's specification

Telephone: 0870 067 3767

Facsimile: 0870 067 3334

E mail: technical@tritonshowers.co.uk

PLEASE READ THIS IMPORTANT SAFETY INFORMATION

- ◆ Products manufactured by Triton are safe and without risk provided they are installed, used and maintained in good working order in accordance with our instructions and recommendations.
- ◆ **WARNING: DO NOT operate shower if frozen, or suspected of being frozen. It must thaw out before using.**
- ◆ DO NOT operate the unit if the showerhead or spray hose becomes damaged.
- ◆ DO NOT restrict flow out of the shower by placing showerhead in direct contact with your body.
- ◆ DO NOT operate the shower if water ceases to flow during use or if water has entered inside the unit because of an incorrectly fitted cover.
- ◆ **WARNING: If restarting the shower immediately after stopping, be aware that a slug of hot water will be expelled for the first few seconds.**

1 GENERAL

- 1.1 Isolate the electrical and water supplies before removing the cover.
- 1.2 Read all of these instructions and retain them for later use.
- 1.3 DO NOT take risks with plumbing or electrical equipment.
- 1.4 Isolate electrical and water supplies BEFORE proceeding with the installation.
- 1.5 The unit must be mounted onto the finished wall surface (on top of the tiles). DO NOT tile up to unit after fixing to wall.
- 1.6 Contact Customer Service (*see back page*), if any of the following occur:
 - a) If it is intended to operate the shower at pressures above the maximum or below the minimum stated.
 - b) If the unit shows a distinct change in performance.
 - c) If the shower is frozen.
- 1.7 If it is intended to operate the shower in areas of hard water (above 200 ppm temporary hardness), a scale inhibitor may have to be fitted. For advice on the Triton Scale Inhibitor, contact Triton Customer Service.
- 1.8 The sprayplate and cartridge must be cleaned regularly with descalant to remove scale and debris, otherwise restrictions to the flow on the outlet of the unit will result in higher temperatures and could also cause the Pressure Relief Device in unit to operate.
- 1.9 This product is not suitable for mounting into steam rooms or steam cubicles.

2 PLUMBING

- 2.1 The plumbing installation must comply with Water Regulations, Building Regulations or any particular regulations as specified by Local Water Company or Water Undertakers and should be in accordance with BS 6700.
- 2.2 The supply pipe must be flushed to clear debris before connecting to the shower unit.
- 2.3 DO NOT solder pipes or fittings within

300 mm of the shower appliance, as heat transfer can damage components.

- 2.4 DO NOT fit any form of outlet flow control as the outlet acts as a vent for the heater can.
- 2.5 DO NOT use excessive force when making connections to the flexible hose or showerhead, finger tight is sufficient.
- 2.6 All plumbing connections MUST be completed BEFORE making the electrical connections.

3 ELECTRICAL

- 3.1 The installation must comply with BS 7671 'Requirements for electrical installations' (IEE wiring regulations), Building Regulations or any particular regulations as specified by the local Electrical Supply Company.
- 3.2 This appliance MUST be earthed.
- 3.3 In accordance with 'The Plugs and Sockets etc. (Safety) Regulations 1994', this appliance is intended to be permanently connected to the fixed wiring of the electrical mains system.
- 3.4 Make sure all electrical connections are tight to prevent overheating.
- 3.5 Fuses DO NOT give personal protection against electric shock.
- 3.6 *To enhance electrical safety* a 30mA residual current device (RCD) should be installed in all UK electric and pumped shower circuits. This may be part of the consumer unit or a separate unit.
- 3.7 Switch the unit off immediately at the isolating switch if water ceases to flow during use.
- 3.8 Other electrical equipment i.e. extractor fans, pumps must not be connected to the circuits within the unit.
- 3.9 Switch off the unit at the isolating switch when not in use. This is a safety procedure recommended with all electrical appliances.
- 3.10 As with all electrical appliances it is recommended to have the shower and installation checked at least every two years by a competent electrician to make sure there is no deterioration due to age and usage.

INTRODUCTION

This book contains all the necessary fitting and operating instructions for your Triton Biscay II electric shower. Please read them carefully.

The shower installation must be carried out by a suitably qualified person and in the sequence of this instruction book.

Care taken during the installation will provide a long, trouble-free life from your shower.

SPECIFICATIONS

Electrical

Nominal power rating at 240V	Nominal power rating at 230V
8.5kW – (40A MCB rating)	7.9kW – (40A MCB rating)
9.5kW – (40A MCB rating)	8.7kW – (40A MCB rating)

Water

Inlet connection – 15 mm diameter.
Outlet connection – ½" BSP male thread.

Entry Points

Water – bottom or back.
Cable – top or back.

Materials

Backplate, cover, controls, showerhead – ABS.
Sprayplate – Acetal.
Elements – Minerally insulated corrosion resistant metal sheathing.

Dimensions

Height – 309 mm
Width – 212 mm
Depth – 95 mm

Standards and Approvals

Splashproof rating IPX4.

Complies with the requirements of current British and European safety standards for household and similar electrical appliances.

Complies with requirements of the British Electrotechnical Approvals Board (BEAB).

Meets with Compliance with European Community Directives (CE).

Due to continuous improvement and updating, specification may be altered without prior notice.

Replacement parts can be ordered from Customer Service. See 'spare parts' for details and part numbers.

ADVICE TO USERS

IMPORTANT: When first installed the unit will be empty. It is essential the unit should contain water before the elements are switched on. It is vital that the commissioning procedure is followed. Failure to carry out this operation will result in damage to the unit and will invalidate the guarantee.

The following points will help you understand how the shower operates:

- a. The electric heating elements operate at a constant rate at your chosen power setting. It is the rate of the water passing through the heater can which determines the water temperature. (The slower the flow, the hotter the water becomes; the faster the flow, the cooler the water).
- b. During winter the mains water supply will be cooler than in the summer, so the flow rate will vary between seasons at any one temperature setting. At different times of the year you may have to adjust the position of the temperature control to maintain your desired temperature setting.
- c. The stabiliser valve minimises variations in shower temperature during mains water pressure changes. If changes in shower temperature are experienced during normal use, it will most likely be caused by the water pressure falling near to or below the minimum level. The drop in pressure may be due to water being drawn off at other points in the house whilst the shower is in use. If pressure drops appreciably below the minimum, the heating elements will automatically cut out.

If ever the water becomes too hot and you cannot obtain cooler water, first check that the sprayplate in the showerhead has not become blocked.

DO NOT place items such as soap or shampoo bottles on top of the unit. Liquid could seep through the joint between the cover and backplate, and possibly damage the sealing rubber.

MAIN COMPONENTS

Inside unit (fig.1)

1. Top cable entry
2. Bottom pipe entry
3. Rear pipe entry area
4. Rear cable entry area
5. Wall screw fixing
6. Terminal block
7. Power selector
8. Stabilising valve
9. Solenoid valve
10. Guide pockets
11. Can and element assembly
12. Thermal cut-out (main)
13. Earth connection
14. Pressure relief device
15. Outlet temperature limiter
16. Neons
17. Trimplate

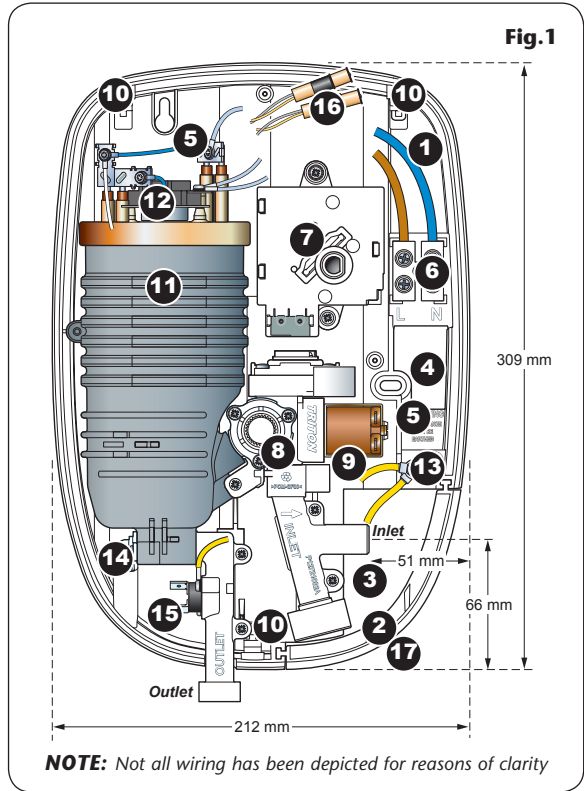

Inside cover (fig.2)

18. Cover tags
19. Start/Stop switch
20. Neon bracket

Screw fixing kit
Instructions, guarantee, etc.

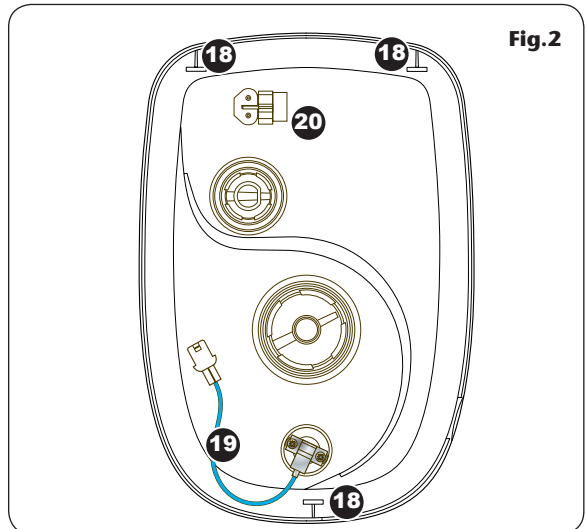

ELECTRICAL REQUIREMENTS

WARNING!
THIS APPLIANCE MUST BE
EARTHED

The installation, supply cable and circuit protection must conform with BS 7671 (IEE wiring regulations) and be sufficient for the amperage required.

The following notes are for guidance only:

1 The shower must only be connected to a 230-240V ac supply. If you are installing a shower with a kilowatt rating above 9kW, it is advisable to contact the local electricity supply company.

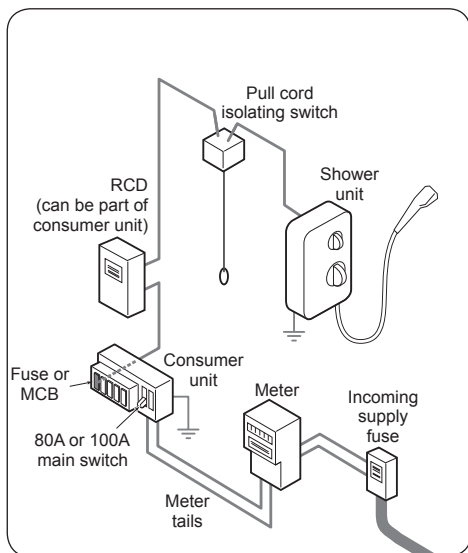
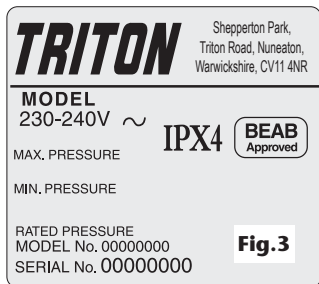

- 1.1** The electrical rating of the shower is shown on the rating label (**fig.3**) within the unit.
- 2** Before making any sort of electrical connection within the installation make sure that no terminal is live. If in any doubt, switch off the whole installation at the consumer unit.
- 3** The shower must be connected to its own independent electrical circuit. IT **MUST NOT** be connected to a ring main, spur, socket outlet, lighting circuit or cooker circuit.
- 3.1** The electrical supply must be adequate for the loading of the unit and existing circuits.
- 4** Check your consumer unit (main fuse box) has a main switch rating of 80A or above and that it has a spare fuse way which will take the fuse or miniature circuit breaker (MCB) necessary for the shower (**fig.4**).
- 4.1** If your consumer unit has a rating below 80A or if there is no spare fuse way, then the installation will not be straightforward and may require a new consumer unit serving the house or just the shower.
- 4.2** You will need to contact the local electricity company. They will check the supply and carry out what is necessary. They will also check the main bonding.
- 5** The earth continuity conductor of the electrical installation must be effectively connected electrically to all exposed metal parts of other appliances and services

Table A

CIRCUIT PROTECTION		
unit rating	MCB	cartridge fuse
7.0kW	30/32A	30A
7.5kW	32A	35A
8.0kW	40A	35A
8.5kW	40A	45A
9.0kW	40A	45A
9.5kW	40/45A	45A
10.5kW	45A	45A

in the room in which the shower is to be installed, to conform to current IEE regulations.

- 5.1 All exposed metallic parts in the bathroom must be bonded together using a cable of at least 4 mm² cross sectional area. These parts include metal baths, radiators, water pipes, taps and waste fittings.
- 6 For close circuit protection DO NOT use a rewirable fuse. Instead use a suitably rated MCB or cartridge fuse (**see table A**).
- 6.1 In the interest of electrical safety a 30mA residual current device (RCD) should be installed in all UK electric and pumped shower circuits. This may be part of the consumer unit or a separate unit.
- 7 A 45 amp double pole isolating switch with a minimum contact gap of 3mm in both poles must be incorporated in the circuit.
- 7.1 It must have a mechanical indicator showing when the switch is in the OFF position, and the wiring must be connected to the switch without the use of a plug or socket outlet.
- 7.2 The switch must be accessible and clearly identifiable, but out of reach of a person using a fixed bath or shower, except for the cord of a cord operated switch, and should be placed so that it is not possible to touch the switch body while standing in a bath or shower cubicle. It should be readily accessible to switch off after using the shower.
- 8 Where shower cubicles are located in any rooms other than bathrooms, all socket outlets in those rooms must be protected by a 30mA RCD.
- 9 The current carrying capacity of the cable must be at least that of the shower circuit protection (**see table B**).
- 9.1 To obtain full advantage of the power provided by the shower, use the shortest cable route possible from the consumer unit to the shower.
- 9.2 It is also necessary to satisfy the disconnection time and thermal constraints which means that for any given combination of current demand, voltage drop and cable size, there is a maximum permissible circuit length.
- 10 The shower circuit should be separated from other circuits by at least twice the diameter of the cable or conduit.
- 10.1 The current rating will be reduced if the cabling is bunched with others, surrounded by thermal loft or wall insulation or placed in areas where the ambient temperature is above 30°C. Under these conditions, derating factors apply and it is necessary to select a larger cable size.

Table B

**Twin and earth PVC insulated cable
Current carrying capacity**

Installed in an insulated wall	In conduit trunking	Clipped direct or buried in a non-insulated wall
6 mm ² 32A	6 mm ² 38A	6 mm ² 46A
10 mm ² 43A	10 mm ² 52A	10 mm ² 63A
16 mm ² 57A	16 mm ² 69A	16 mm ² 85A

Note: Cable selection is dependent on derating factors

- 10.2 In the majority of installations, the cable will unavoidably be placed in one or more of the above conditions. This being so, it is strongly recommended to use a minimum of 10 mm cabling throughout the shower installation.
- 10.3 In any event, it is essential that individual site conditions are assessed by a competent electrician in order to determine the correct cable size and permissible circuit length.

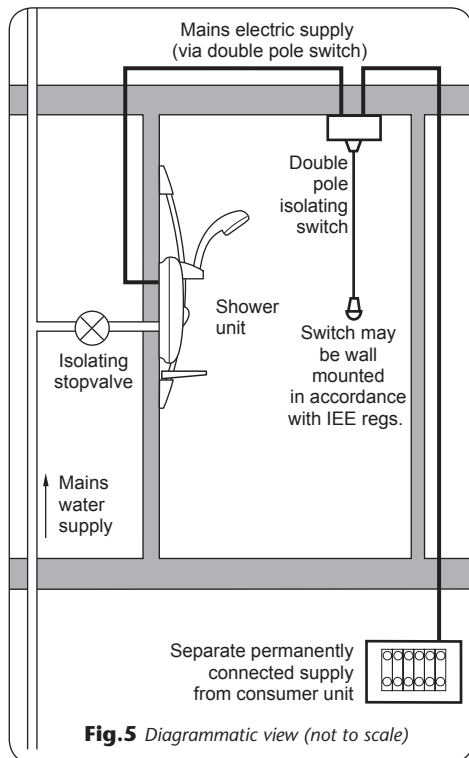

Fig.5 Diagrammatic view (not to scale)

WATER REQUIREMENTS

The installation must be in accordance with Water Regulations/Bylaws.

To guarantee activating the heating elements, the shower must be connected to a mains water supply with a minimum running pressure of 100kPa (1.0 bar) at a minimum flow rate of nine litres per minute. The maximum static pressure must be no greater than 1 000kPa (10 bar).

Note: If the stated flow rates are not available, it may not be possible to achieve the best performance from the unit throughout the year.

For guidance on the running and static pressures contact the local Water Authority or consult a competent plumber.

During periods of high ambient temperatures it may be necessary to select a low power setting to achieve your preferred shower temperature.

The water supply can be taken from a cold water storage cistern provided there is a minimum head of ten metres above the showerhead. It must be an independent supply to the shower only.

If it is intended to operate the shower at pressures above the maximum or below the minimum stated, contact Customer Service for advice.

Fig.5 shows a typical system layout.

DO NOT use jointing compounds on any pipe fittings for the installation.

SITING OF THE SHOWER

IMPORTANT: If installing onto a tiled wall always mount the unit on the surface of the tiles. NEVER tile up to the unit.

Refer to **fig.6** for the correct siting of the shower. Position the unit where it will NOT be in direct contact with water from the showerhead. Position the shower unit vertically.

Allow enough room between the ceiling and the shower to access the cover top screws. Leave enough space between the left-hand side of the unit and the wall to allow access to the pressure relief device (PRD) in the future.

Note: Water regulations require the showerhead be 'constrained by a fixed or sliding attachment so that it can only discharge water at a point not less than 25 mm above the spill-over level of the relevant bath, shower tray or other fixed appliance'. The use of the supplied gel hanger/hose guide will in most cases meet this requirement, but if the showerhead can be placed within a bath, basin or shower tray, then a double check valve, or similar, must be fitted in the supply pipework to prevent back-flow.

Pressure relief safety device

A pressure relief device (PRD) is designed into the shower unit which complies with European standards. The PRD provides a level of appliance protection should an excessive build up of pressure occur within the shower.

DO NOT operate the shower with a damaged or kinked shower hose, or a blocked showerhead which can cause the PRD to operate.

When commissioning, the showerhead must be removed from the flexible hose, while at the same time the temperature control must be at the minimum flow position. Failure to follow this procedure may also cause the PRD to operate.

Make sure the shower is positioned over a bath or shower tray because if the PRD operates, then water will eject from the bottom of the unit. Should this happen, turn off the electricity and water supplies to the shower at the isolating switch and stopvalve. Contact Customer Service for advice on replacing the PRD.

WARNING!

The shower must not be positioned where it will be subjected to freezing conditions.

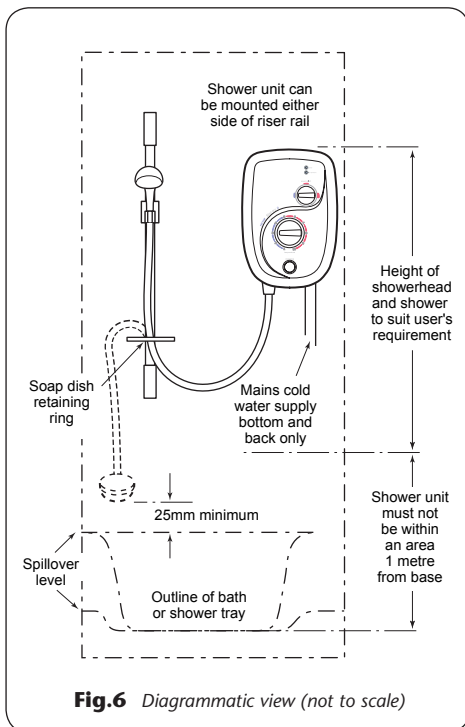

IMPORTANT: The unit must be mounted on a flat surface which covers the full width and length of the backplate. It is important that the wall surface is flat otherwise difficulty may be encountered when fitting the cover and subsequent operation of the unit may be impaired.

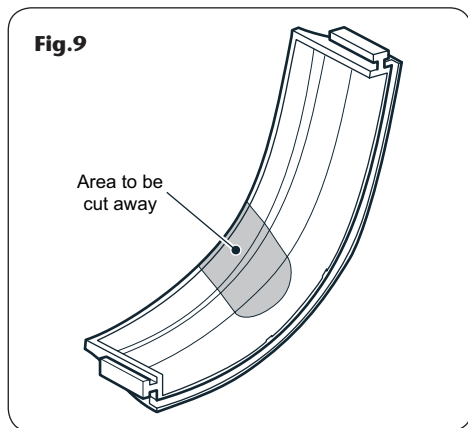
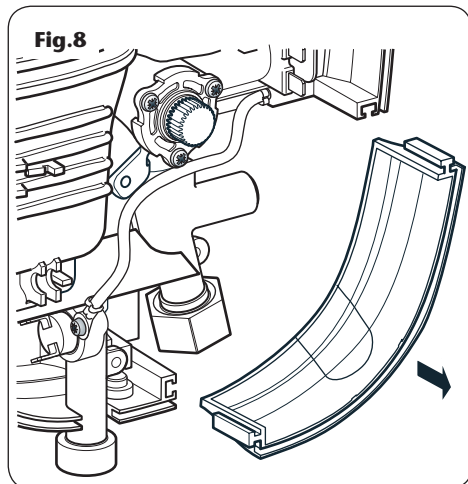
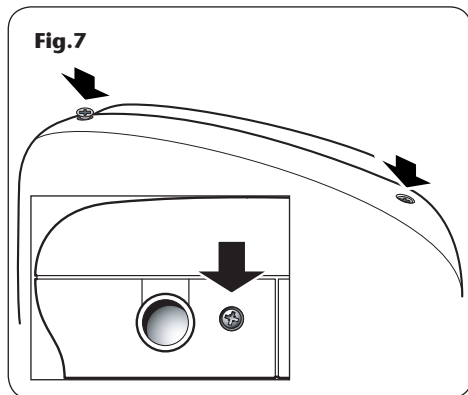

FITTING THE SHOWER TO THE WALL

WARNING!

Check there are no hidden cables or pipes before drilling holes for wall plugs. Use great care when using power tools near water. The use of a residual current device (RCD) is recommended.

Note: The control knob is an integral part of the cover – DO NOT attempt to remove it.

Unscrew the two top and one bottom retaining screws (**fig.7**) and lift the cover from the backplate. To access the pipe and cable connections lift off the trimplate (**fig.8**).

Entry positions for the mains water are from the bottom or from the rear. Cable entry is via the top or rear.

Note: Deviations from the designated entry points will invalidate product approvals.

If bottom surface entry is required for the mains cold water, then the necessary opening will need to be cut out in the trimplate (**fig.9**).

If surface cable entry from the top is required then a small area will need to be cut out in the backplate (**fig.10**).

If installing a feed pipe from the rear or bottom, the centre of the inlet valve to the wall surface is 20 mm (**fig.11**).

Note: If entry is from the rear, the nut of the compression fitting will be partially behind the surface of the wall (**fig.11**). This area MUST be left clear when plastering over the pipework in order to make the nut accessible for future adjustments.

After choosing the site for the shower, use the backplate as a template and mark the two fixing holes (**fig.12**).

Drill and plug to suit the fixing screws supplied. *(The wall plugs provided are suitable for most brick walls – use an appropriate masonry drill, but if the wall is plasterboard or a soft building block, you must use suitable wall plugs and an appropriate drill bit).*

Screw top fixing screw into position leaving the

base of the screw head protruding 6mm out from the wall.

Hook the backplate over the top screw and fit the bottom fixing screw into position. Do not fully tighten the screws at this stage, as the fixing holes are elongated to allow for out of square adjustment after the plumbing connections have been completed.

Note: If replacing an older model shower unit which has been tiled around, an installation trim is available to cover the untiled area. See 'spare parts' for details.

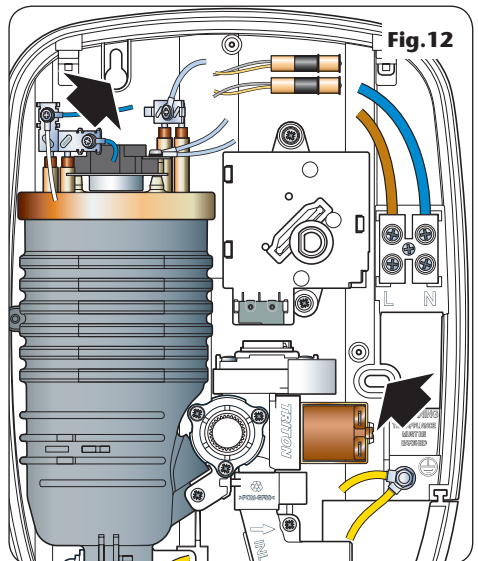
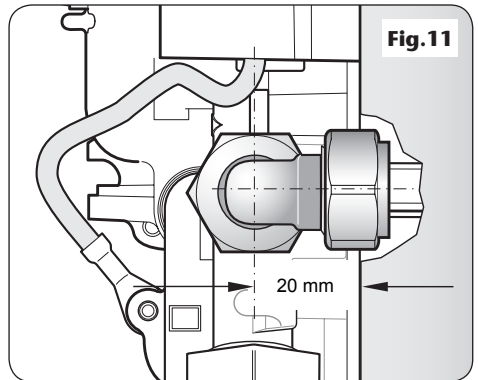
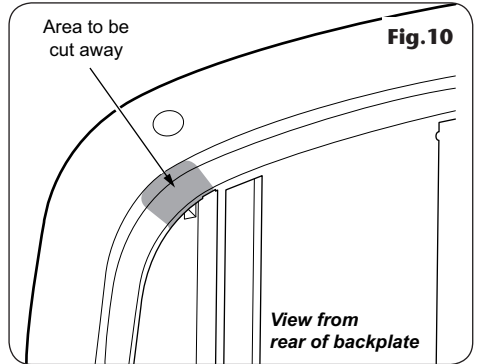

WARNING!

The outlet of the shower acts as a vent and must NOT be connected to anything other than the hose and showerhead supplied.

PLUMBING CONNECTIONS

Plumbing to be carried out before wiring

DO NOT use jointing compounds on any pipe fittings for the installation.

DO NOT solder fittings near the shower unit as heat can transfer along the pipework and damage components.

Compression fittings MUST be used to connect to the inlet of the shower. (Push-on fittings must NOT be used as full engagement cannot be guaranteed).

Note: An additional stopvalve (complying with Water Regulations) MUST be fitted in the mains water supply to the shower as an independent means of isolating the water supply should maintenance or servicing be necessary.

IMPORTANT: Before completing the connection of the water supply to the inlet of the shower, flush out the pipework to remove all swarf and system debris. This can be achieved by connecting a hose to the pipework and turning on the mains water supply long enough to clear the debris to waste.

Procedure

Turn off water supply either at the mains stopvalve or the isolating stopvalve. Connect the mains water supply to the inlet of the shower via 15 mm copper, stainless steel or plastic pipe using a 15 mm x 15 mm elbow compression fitting.

DO NOT use excessive force when making these connections.

Make sure the backplate is square on the wall and tighten the two retaining screws which hold it to the wall.

Turn on the mains water supply and check for leaks in the pipework connection to the shower.

IMPORTANT: Using a suitable sealant, always seal around the incoming pipework to prevent water entering the wall.

Note: At this stage no water can flow through the unit.

ELECTRICAL CONNECTIONS

SWITCH OFF THE ELECTRICITY SUPPLY AT THE MAINS.

Fig.13 shows a schematic wiring diagram.

The cable entry points are shown in **fig.1**. The cable can be surface clipped, hidden or via 20mm conduit.

Note: Conduit entry can only be from rear. Route the cable into the shower unit and connect to the terminal block (**fig.14**) as follows:

Earth cable to terminal marked **E** 

Neutral cable to terminal marked **N**

Live cable to terminal marked **L**

IMPORTANT: Fully tighten the terminal block screws and make sure that no cable insulation is trapped under the screws. Loose connections can result in cable overheating.

Note: The supply cable earth conductor must be sleeved. The outer sheath of the supply cable must be stripped back to the minimum.

The supply cable must be secured either by routing through conduit or in trunking or by embedding in the wall, in accordance with current IEE regulations.

The use of connections within the unit, or other points in the shower circuit, to supply power to other equipment i.e. extractor fans, pumps etc. will invalidate the guarantee.

DO NOT SWITCH ON THE ELECTRICITY SUPPLY UNTIL THE COVER HAS BEEN FITTED.

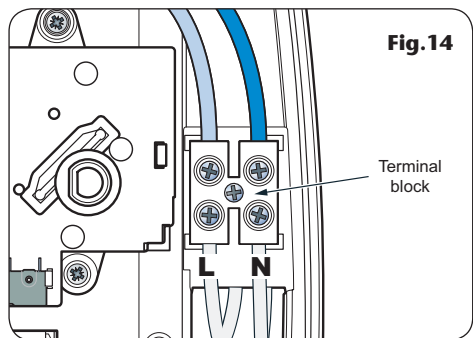
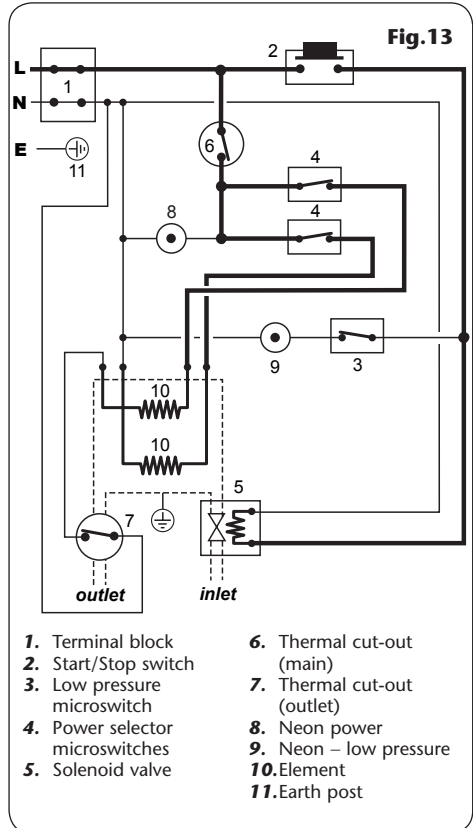

Note: The elements on UK models are to 240V specification and will give a lower kW rating if the voltage supply is below 240V.

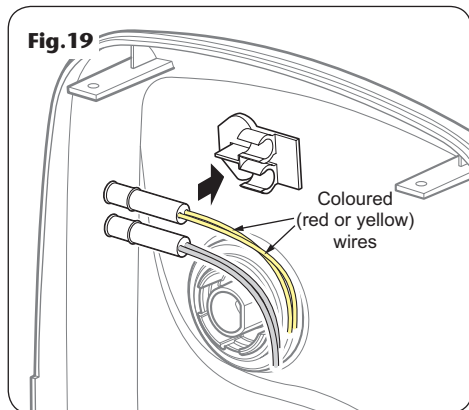
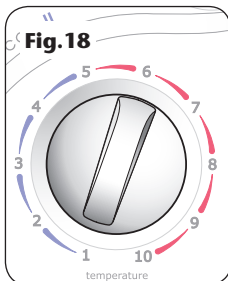
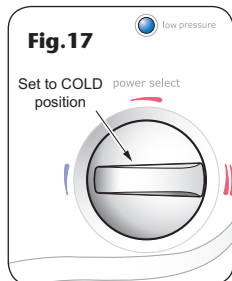
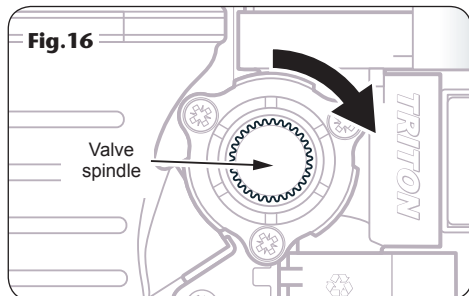
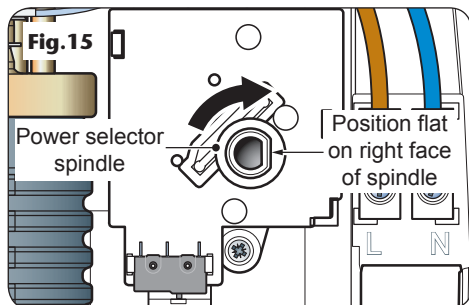

REPLACING THE COVER

Refit the trimplate. Turn the POWER selector spindle clockwise to the position shown in **fig.15**.

Turn the stabiliser valve spindle fully clockwise until resistance is felt (**fig.16**).

On the cover turn the power selector to the COLD position (**fig.17**) and position the temperature control so that it points to the '10' (**fig.18**).

IMPORTANT: Before finally fitting the cover, the following steps must be taken:

- Check the plumbing connections are watertight.
- Check the terminal block screws are fully tightened.
- Make sure the pipe and cable entering the unit do not prevent the cover locating correctly to the backplate.
- Check the power selector is in the COLD position and the temperature control is in the '10' position.

Offer the cover to the unit.

Plug the two neons located on the backplate onto the bracket inside the cover (**fig.19**). The neon with the coloured (red or yellow) wires clips into the upper position and the remaining neon fits into the lower position.

Attached to the START/STOP switch inside the cover is a two-wire lead. Connect the socket on the end of the lead to the plug leading from the backplate (**fig.20**).

Note: The plug and socket can only fit one way.

Carefully locate the cover tags into the guide pockets on the backplate and make sure the wires are not trapped.

Note: DO NOT remove the cable ties in this unit.

Guide the cover into position so that the knob spindle locates correctly (minor adjustment may be necessary to align the knob and spindle).

Should any difficulty arise, recheck the points above.

While applying slight pressure to the front cover, secure in place using the three retaining screws.

COMMISSIONING

WARNING!

Before normal operation of the shower, it is essential the following commissioning procedure is completed correctly.

BEFORE COMMISSIONING, MAKE SURE THE COVER IS CONNECTED AND FITS CORRECTLY.

IMPORTANT: The first operation of the shower is intended to flush out any remaining unit debris, and to make sure the heater unit contains water before the elements are switched on.

This operation must be carried out with the flexible hose screwed to the outlet but WITHOUT the showerhead attached.

The COLD position must be used. Make sure the outlet from the flexible hose is directed to waste.

Before turning on the electric and mains water supplies to the shower, check that the power selector is in the COLD position (**fig.21**) and the temperature control is turned to position '10', the minimum flow position (**fig.21**).

Note: Failure to turn the temperature control to '10' may cause the PRD to operate.

Turn on the electric and mains water supplies to the shower.

Press the START/STOP button (**fig.21**) and wait until water starts to flow from the flexible hose.

Slowly turn the temperature control fully anti-clockwise to '1', the maximum flow position (**fig.22**).

It will take about thirty seconds for a smooth flow of water to be obtained while air and any debris is being flushed from the shower.

When there is a smooth flow of water turn the temperature control from '1' to '10' and back again several times to release any trapped air within the unit.

Once flushing out has been completed, stop the water flow by pressing the START/STOP button.

Fit the showerhead to the flexible hose and place in the showerhead holder.

The shower is now ready for normal operation.

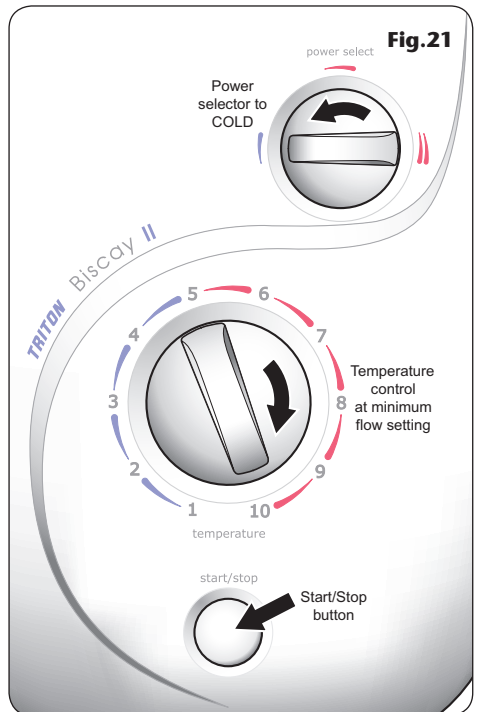
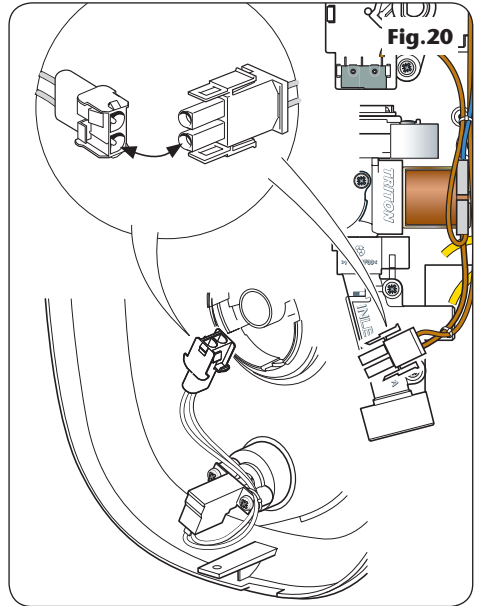

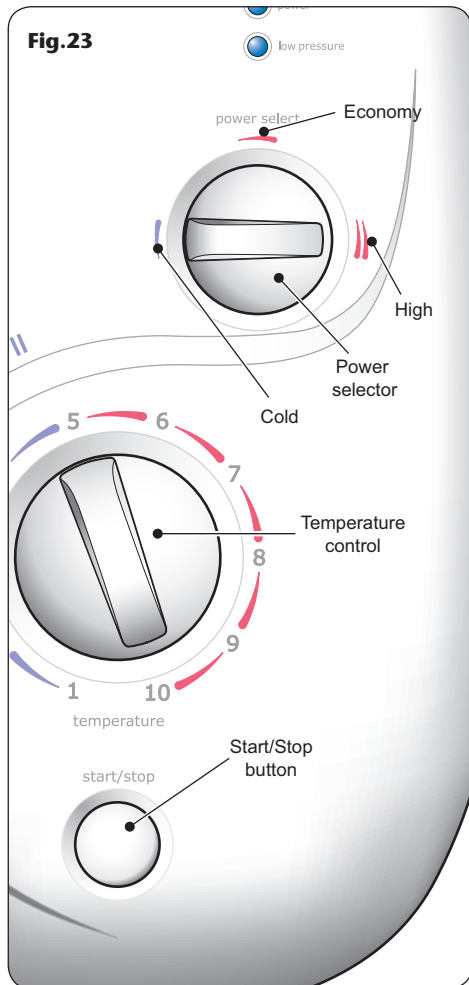
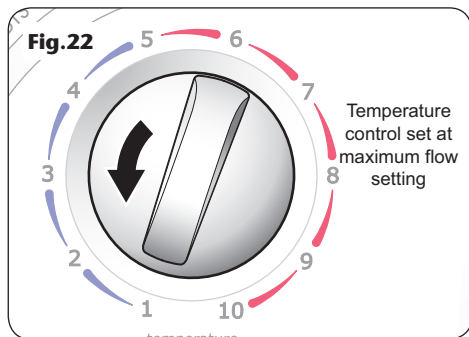

OPERATING THE SHOWER

WARNING!

Before normal operation of the shower, it is essential that the commissioning procedure has been completed correctly.

To start the shower

Press the START/STOP button and water will flow.

To stop the shower

Press the START/STOP button once more and water will cease to flow.

WARNING!

If restarting immediately after stopping, be aware that a slug of hot water will be expelled for the first few seconds.

To use the power selector

The power selector has three positions — COLD, ECONOMY and HIGH (**fig.23**).

The blue symbol  is for COLD water only. Adjusting the temperature control at this setting will only change the force of the water from the showerhead. (It will not alter the water temperature).

The red symbol  is the ECONOMY setting for using less energy when the ambient mains water temperature is high during warmer months. Temperature adjustment at this setting is via the temperature control

Note: If the stated flow rate required for the unit cannot be met due to low water pressure, it will be necessary to operate the unit on this setting during the warmer months because of flow rate limitations entering the unit.

The red symbol  is the HIGH power setting which allows the highest flow achievable for your preferred temperature. This setting should normally be regarded as optimum shower performance throughout the year. Temperature

adjustment at this setting is via the temperature control.

To adjust the shower temperature

The water temperature is altered by increasing or decreasing the flow rate of the water through the shower via the temperature control (fig.23).

After obtaining your showering temperature, the number can be left as the normal setting and should only need altering to compensate for seasonal changes in ambient water temperature.

Note: The preferred number on ECONOMY will give a different temperature to the same number position on HIGH.

To decrease the shower temperature

Turn the temperature control anti-clockwise; this will increase the flow of water through the shower therefore decreasing the water temperature, and is indicated by lower numbers.

To increase the shower temperature

Turn the temperature control clockwise; this will decrease the flow of water through the shower therefore increasing the water temperature, and is indicated by higher numbers.

Note: It is advisable to be certain that the showering temperature is satisfactory by testing with your hand before stepping under the showerhead. There will always be a time delay of a few seconds between selecting a flow rate and the water reaching the stable temperature for that flow rate.

CAUTION: It is recommended that persons who may have difficulty understanding or operating the shower controls should not be left unattended while showering. Special consideration should be given to young children and the less able bodied.

WARNING!

After any servicing of mains water supply, always make sure the unit is started on COLD in order to purge any air in the pipework.

Note: In normal use, it is in order to leave the water supply permanently on to the shower unit, but as with most electrical appliances, **the unit must be switched off at the isolating switch when not in use.**

Fig.24

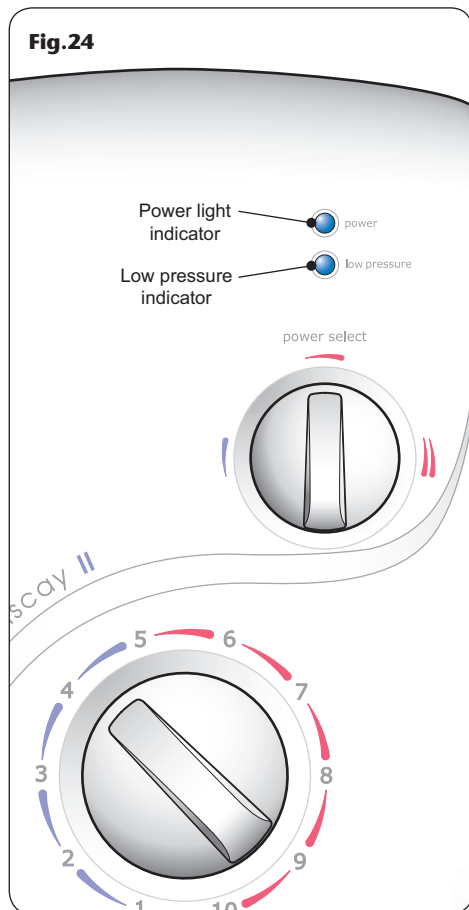

OPERATING FUNCTIONS

Power on indicator (fig.24)

When the electricity supply to the shower is switched on at the isolating switch, the neon power indicator will light.

Low pressure indicator (fig.24)

If this indicator lights, this means the water pressure has fallen below the minimum required for correct operation of the shower, resulting in the low pressure cut-out operating. This switches off power to the heating elements preventing any undue temperature rises (water will continue to flow). Power will automatically be restored when adequate water pressure returns.

Temperature limiter

During normal operation if an overheat temperature is sensed power to the elements will be reduced, although water will continue to flow. When the temperature has cooled sufficiently, power to the elements will be automatically restored to the settings at the time of interruption.

Safety cut-out

The unit is fitted with a non-resettable thermal cut-out safety device. In the event of abnormal operation which could cause unsafe temperatures within the unit, the device will disconnect the heating elements. It will require a visit from a qualified engineer to determine the nature of the fault and replace the safety device, once the unit has been repaired.

FITTING THE RISER RAIL

WARNING!

Check there are no hidden cables or pipes before drilling holes for wall plugs. Use great care when using power tools near water. The use of a residual current device (RCD) is recommended.

Note: It is recommended that the water and electric supplies to the shower are turned off while the riser rail kit is being installed.

Decide the position for the rail on the wall within the shower area. Proceed as follows:

Fit the showerhead holder onto the riser rail. The correct orientation of the holder is when the showerhead holder is sloping **DOWN** (**fig.25**).

To fit the showerhead holder onto the riser rail unit, press and hold the button on the underneath of the showerhead holder to release the locking mechanism, then slide onto the rail.

Slide the supplied soap dish onto the riser rail below the showerhead holder (**fig.26**).

Slide the top and bottom finishing trims onto the riser rail (**fig.27**).

Push the two fixing brackets into the ends of the riser rail (**fig.28**).

Offer the rail assembly to the wall (**fig.29**).

Using the brackets as templates, mark two upper holes and two lower holes.

Note: There are four provisions for screws per bracket. Select the two most suitable for your requirements. Make sure the rail is aligned vertically.

Drill and plug the wall. (*The wall plugs provided are suitable for most brick walls – use an appropriate masonry drill, but if the wall is plasterboard or a soft building block, use suitable wall plugs and an appropriate drill bit.*)

Screw to the wall with the fixing screws supplied.

Slide the finishing trims onto the brackets. Make sure the lug on each rail bracket end engages into the slot on the fatter end of each trim before push fitting the thinner ends in place (**fig.30**).

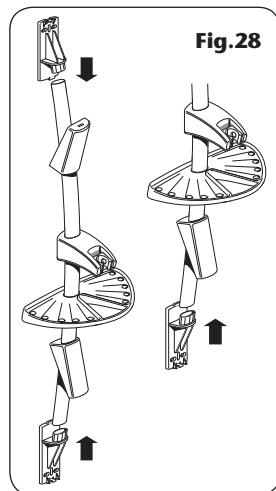
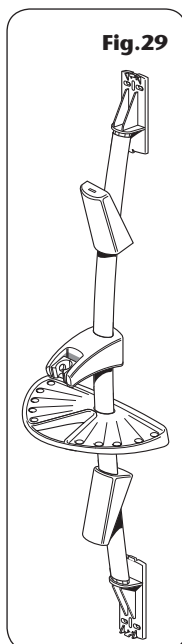
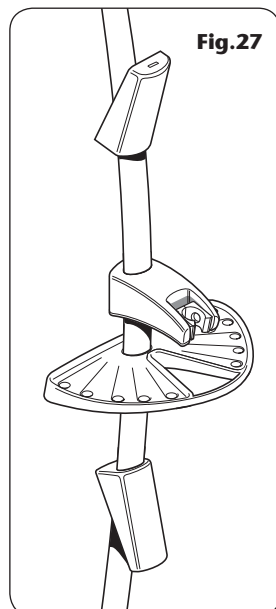
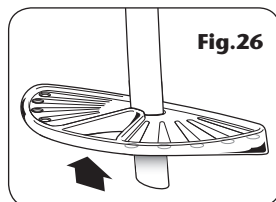
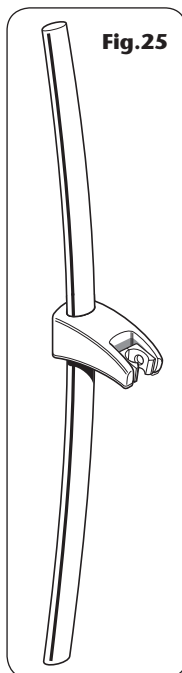
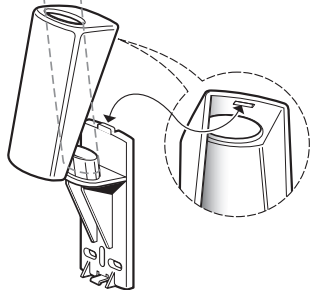

Fig.30



To remove a trim, push a small screwdriver or similar through the slot in the trim end and carefully pull away from the wall bracket.

Slide the soap dish down the rail so that its bracket engages on top of the lower finishing trim.

Adjusting the showerhead holder

To adjust the height, press the button underneath the holder to release the locking mechanism (**fig.31**). Still pressing the button, move the holder up or down to suit user's requirement.

Fig.31

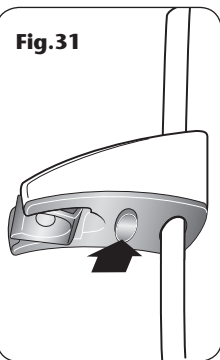
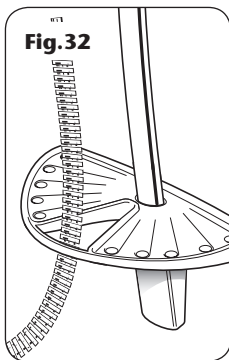

Fig.32



FITTING THE HOSE AND SHOWERHEAD

Feed the flexible hose through the soap dish opening (**fig.32**) so the dish acts as a retaining ring (Water Regulations).

Screw the flexible hose to the shower outlet and showerhead, checking the supplied washers are in place at both ends of the flexible hose (**fig.33**).

Place the showerhead into the holder and check that it fits correctly (**fig.34**).

Note: The holder is slightly tapered and the showerhead and hose will only fit from one direction.

IMPORTANT: It is the conical end of the hose which grips into the holder. The showerhead will not fit in the holder without the hose attached.

Fig.33

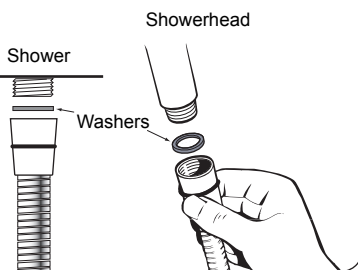
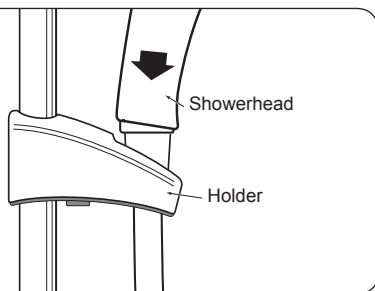

Fig.34



ADJUSTING THE SHOWERHEAD

Five showerhead patterns are available (**fig.35**). Adjust the spray pattern by turning the bezel on the showerhead in either direction until the desired pattern is obtained.

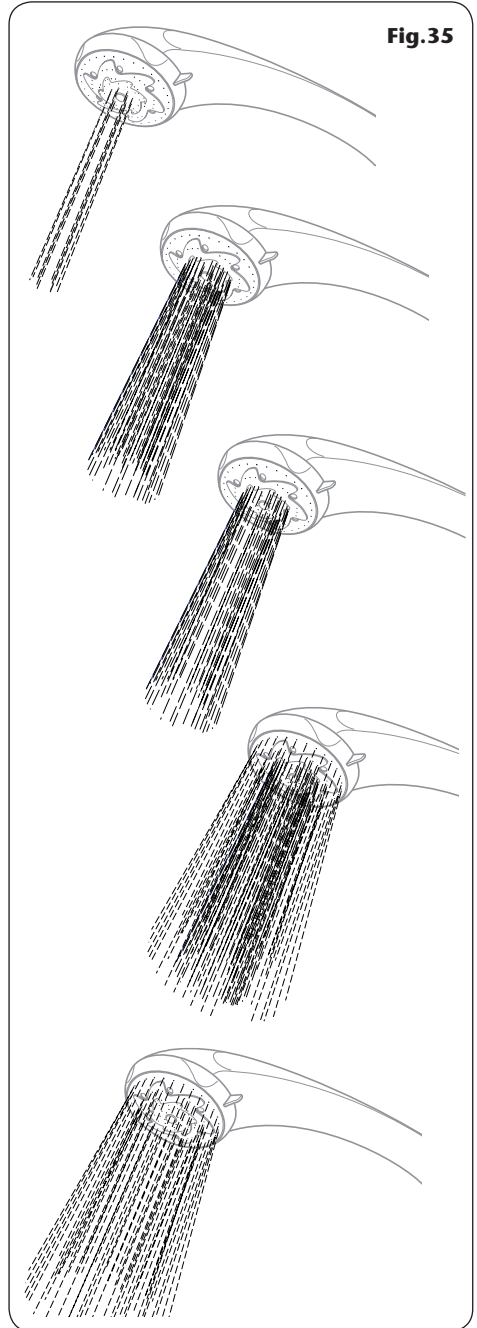

Fig.35

WARNING!

DO NOT use 'powerful' abrasive or solvent cleaning fluids when cleaning the shower as they may damage the plastic fittings.

CLEANING THE SHOWERHEAD

Before cleaning, turn off the unit at the isolation switch to avoid the shower being accidentally switched on.

IT IS IMPORTANT TO KEEP THE SHOWERHEAD CLEAN TO MAINTAIN THE PERFORMANCE OF THE SHOWER. The hardness of the water will determine the frequency of cleaning. For example, if the shower is used every day in a very hard water area, it may be necessary to clean the showerhead on a weekly basis.

Sprayplate removal

There is no need to remove the showerhead from the hose.

Using the removal tool supplied (**fig.36**), locate the raised 'bosses' into the recesses in the sprayplate. Hold in firmly and twist anti-clockwise (**fig.37**). This movement may turn the cartridge assembly as well until it reaches a 'stop'. Hold the cartridge firmly and continue to twist anti-clockwise. Having loosened the sprayplate, it can be unscrewed and removed completely.

Clean the sprayplate with a suitable brush or preferably leave it to soak overnight in a mild proprietary descalent. Make sure all traces of scale are removed and thoroughly rinse in clean water afterwards.

Before replacing the sprayplate, switch on the power at the isolating switch and direct the hose and showerhead to waste.

Turn the temperature control fully anti-clockwise. Press the START/STOP button.

This operation will flush out any loose scale deposits in the unit and showerhead. Stop after about thirty seconds.

Refit the sprayplate by screwing clockwise. Use the tool to screw the sprayplate tight.

Fig.36

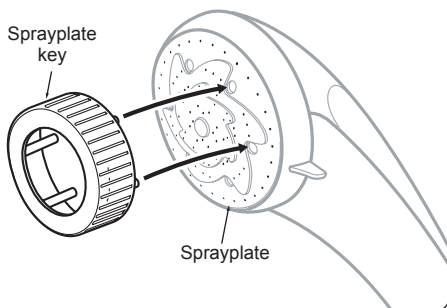
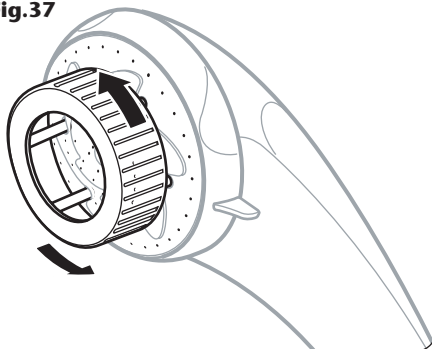

Fig.37



INSTRUCTIONS FOR INSTALLERS AND SERVICE ENGINEERS ONLY**CLEANING THE INLET FILTER**

It is recommended that the filter is periodically cleaned in order to maintain the performance of the shower. It is essential that this operation is carried out by an installer or service engineer.

IMPORTANT: BEFORE SERVICING, SWITCH OFF BOTH THE ELECTRICITY SUPPLY AND WATER SUPPLY AT THE MAINS.

The inlet filter is situated at the bottom of the inlet pipe (**fig.38**).

To gain access to the filter, remove the trimplate and then unscrew the retaining nut from the bottom of the inlet pipe.

When cleaning the wire mesh filter, **DO NOT** use a sharp object, as it will cause damage. It is preferable to use an old toothbrush or similar.

When refitting the filter, **DO NOT** overtighten the retaining nut.

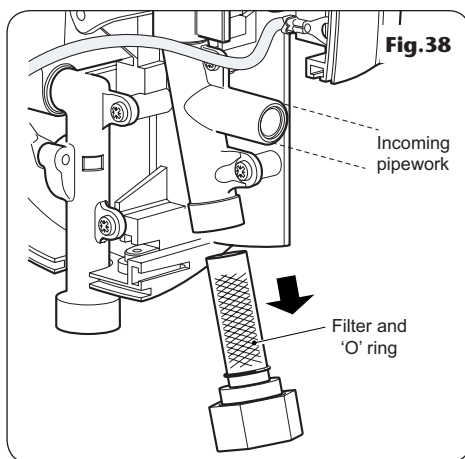

SPARE PARTS

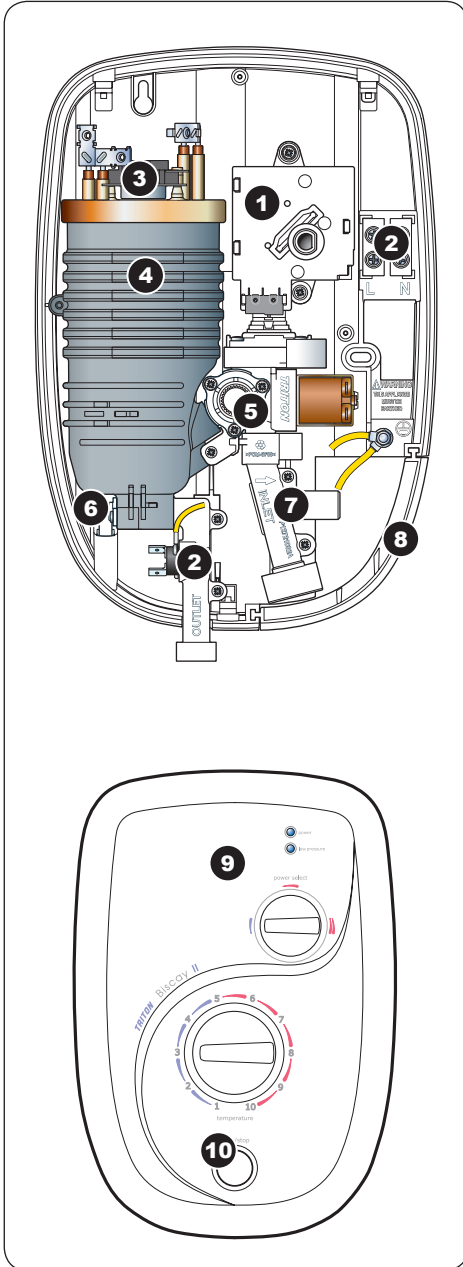

Ref	Description	Part No
1.	Power selector including microswitches	S12121008
2.	Terminal block & outlet pipe assembly	S12721003
3.	Thermal cut-out	22011180
4.	Heater can assembly	
	8.5kW	P12120701
	9.5kW	P12120702
5.	Stabiliser valve/solenoid assembly	P12120800
6.	PRD & 'O' ring	82800450
7.	Inlet pipe assembly	S12721002
8.	Trimplate	7053372
	– Neon and switch assembly	P12720903
9.	Cover assembly	S12720601
10.	Start/stop switch assembly	82301310

SPARE PARTS

Ref. Description	Part No.
11. 5 mode kwik kleen showerhead	22011270
12. Brackets (pair)	22010430
13. Cover trims (pair)	22010440
14. Riser rail	22011310
15. Showerhead holder	22010460
16. Soap dish	22010470
17. Flexible hose	28100110
18. Installation trim (<i>optional</i>)	7053417

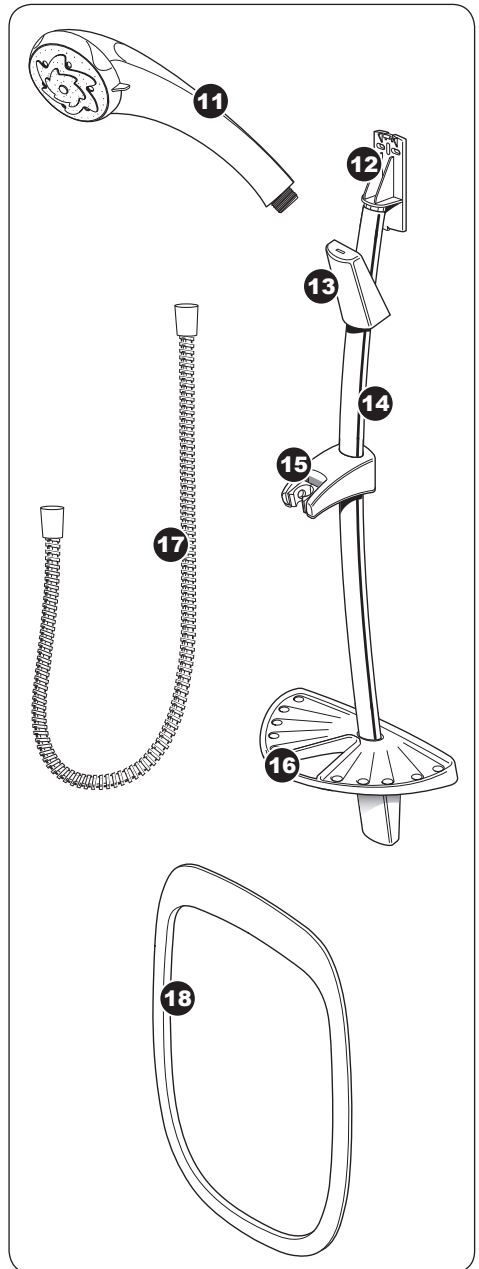

FAULT FINDING

IMPORTANT: Switch OFF the electricity at the mains supply and remove the circuit fuse before attempting any fault finding inside the unit.

Problem/Symptom	Cause	Action/Cure
1. Shower inoperable, no water flow.	1.1 Interrupted power supply.	1.1.1 Blown fuse or circuit breaker. Check supply. Renew or reset fuse or circuit breaker. If it fails again, consult a qualified electrician. 1.1.2 Power cut? Check other appliances and if necessary, contact local Electricity Supply Co.
	1.2 Unit malfunction.	1.2.1 Have unit checked. Ring Customer Service.
2. Water too hot.	2.1 Not enough water flowing through the shower.	2.1.1 Increase the flow rate via temperature control. 2.1.2 Blocked showerhead – clean blocked sprayplate.
	2.2 Blockage in supply.	2.2.1 Check if stop taps are fully open. Check if blockage in inlet filter.
	2.3 Increase in ambient water temperature.	2.3.1 Switch to economy power setting and readjust flow rate to give required temperature.
3. Water temperature cycling hot/cool at intervals.	3.1 Heater cycling on outer temperature limiter.	3.1.1 See 'Water too hot' causes 2.1, 2.2 and 2.3 and their action/cures. If it continues, contact Customer Service.
4. Water too cool or cold.	4.1 Too much flow.	4.1.1 Reduce flow rate via temperature control.
	4.2 Water pressure below minimum stated on rating label.	4.2.1 Check low pressure indicator. If lit, continue with remainder of checks. If not lit, see 4.1 & 4.4.
		4.2.2 Is water supply mains or tank fed ?
		4.2.3 If tank fed, replumb to mains water supply or see 4.2.5.
		4.2.4 If mains fed, make sure the mains stop valve is fully open and that there are no other restrictions in the supply or filter while shower is in use, or see 4.2.5.
		4.2.5 Fit a pump to give minimum pressure – contact Customer Service for advice.
4.3 Reduction in ambient water temperature.	4.3.1 Switch to full power setting and readjust the flow rate via the temperature control to give required temperature.	
4.4 Electrical malfunction or safety cut-out has operated.	4.4.1 Have unit checked by suitably qualified electrician or contact Customer Service.	

FAULT FINDING

Problem/Symptom	Cause	Action/Cure
5. Shower varies from normal temperature to cold during use.	5.1 Water pressure has dropped below minimum required. Indicator lit.	5.1.1 Wait until the water pressure resumes to normal. Low pressure indicator extinguishes.
6. Pressure relief device has operated (water ejected from PRD tube).	6.1 Blocked showerhead.	6.1.1 Clean sprayplate and then fit a new PRD.
	6.2 Twisted/blocked flexible shower hose.	6.2.1 Check for free passage through hose. Replace hose if necessary and then fit new PRD.
	6.3 Showerhead not removed while commissioning.	6.3.1 Fit new PRD. Commission unit with showerhead removed.
7. Shower switch fails to shut off when STOP button is pressed.	7.1 Faulty START/STOP switch.	7.1.1 Replace START/STOP switch.
	7.2 Debris in solenoid.	7.2.1 Replace solenoid valve assembly.
	7.3 Faulty control PCB.	7.3.1 Replace control PCB.

Note: Identify cause of operation before fitting new PRD unit.
When fitting a new PRD, follow the commissioning procedure.

It is advised all electrical maintenance/repairs to the shower should be carried out by a suitably qualified person.

**In the unlikely event of a fault occurring please contact Triton Customer Service.
Do not remove the shower from the installation.**



Service Policy

In the event of a complaint occurring, the following procedure should be followed:

- 1 Telephone Customer Service on 0870 067 3333 (0845 762 6591 in Scotland and in Northern Ireland), having available the model number and power rating of the product, together with the date of purchase.
- 2 Triton Customer Service will be able to confirm whether the fault can be rectified by either the provision of a replacement part or a site visit from a qualified Triton service engineer.
- 3 If a service call is required the unit must be fully installed for the call to be booked and the date confirmed. In order to speed up your request, please have your postcode available when booking a service call.
- 4 It is essential that you or an appointed representative (who must be a person of 18 years of age or more) is present during the service engineer's visit and receipt of purchase is shown.
- 5 A charge will be made in the event of an aborted service call by you but not by us, or where a call under the terms of guarantee has been booked and the failure is not product related (i.e. scaling and furring, incorrect water pressure, pressure relief device operation, electrical installation faults).
- 6 If the product is no longer covered by the guarantee, a charge will be made for the site visit and for any parts supplied.
- 7 Service charges are based on the account being settled when work is complete, the engineer will then request payment for the invoice. If this is not made to the service engineer or settled within ten working days, an administration charge will be added.

Replacement Parts Policy

Availability: It is the policy of Triton to maintain availability of parts for the current range of products for supply after the guarantee has expired. Stocks of spare parts will be maintained for the duration of the product's manufacture and for a period of five years thereafter.

In the event of a spare part not being available a substitute part will be supplied.

Payment: The following payment methods can be used to obtain spare parts:

- 1 By post, pre-payment of pro forma invoice by cheque or money order.
- 2 By telephone, quoting credit card (MasterCard or Visa) details.
- 3 By website order, www.tritonshowers.co.uk

Triton Showers
Triton Road
Nuneaton
Warwickshire CV11 4NR

Triton is a division of Norcross Group (Holdings) Limited

TRITON STANDARD GUARANTEE

Triton guarantee this product against all mechanical and electrical defects arising from faulty workmanship or materials for a period of two years for domestic use only, from the date of purchase, provided that it has been installed by a competent person in full accordance with the fitting instructions.

Any part found to be defective during this guarantee period we undertake to repair or replace at our option without charge so long as it has been properly maintained and operated in accordance with the operating instructions, and has not been subject to misuse or damage.

This product must not be taken apart, modified or repaired except by a person authorised by Triton. This guarantee applies only to products installed within the United Kingdom and does not apply to products used commercially. This guarantee does not affect your statutory rights.

What is not covered:

- 1 Breakdown due to: **a)** use other than domestic use by you or your resident family; **b)** wilful act or neglect; **c)** any malfunction resulting from the incorrect use or quality of electricity, gas or water or incorrect setting of controls; **d)** faulty installation.
- 2 Repair costs for damage caused by foreign objects or substances.
- 3 Total loss of the product due to non-availability of parts.
- 4 Compensation for loss of use of the product or consequential loss of any kind.
- 5 Call out charges where no fault has been found with the appliance.
- 6 The cost of repair or replacement of pressure relief devices, showerheads, hoses, riser rails and/or wall brackets, isolating switches, electrical cable, fuses and/or circuit breakers or any other accessories installed at the same time.
- 7 The cost of routine maintenance, adjustments, overhaul modifications or loss or damage arising therefrom, including the cost of repairing damage, breakdown, malfunction caused by corrosion, furring, pipe scaling, limescale, system debris or frost.

Customer Service: ☎ 0870 067 3333

**Scottish and Northern Ireland
Customer Service:** ☎ 0845 762 6591

Trade Installer Hotline: ☎ 0870 067 3767
Fax: 0870 067 3334

www.tritonshowers.co.uk

E mail: technical@tritonshowers.co.uk

Extended Warranty AVAILABLE NOW. Call 0870 067 3333 for more details.