

TRITON

AVIOR
Concentric
thermostatic
mixer shower



**Installation and
operating
instructions**



INSTALLERS PLEASE NOTE THESE INSTRUCTIONS ARE TO BE LEFT WITH THE USER

CONTENTS	Page
Introduction	1
Safety warnings	1
Main components	2
Site requirements	3
Typical suitable installations	4 – 5
Getting started	6
Siting of the shower	6
Installation	6 – 7
Rising or falling supplies	8
Rear entry supplies	8 – 9
Fitting the mixer	9
Leak testing	9
Commissioning	10
Adjusting the maximum temperature setting	10
Operating the shower	11
Cleaning	11
Spare parts	12 – 13
Fault finding	14 – 15
Guarantee, service policy, etc.	rear cover

To check the product suitability for commercial and multiple installations, please contact Triton's specification

Telephone: 0870 067 3767

Facsimile: 0870 067 3334

E mail: technical@tritonshowers.co.uk

INTRODUCTION

This book contains all the necessary fitting and operating instructions for your Triton Avior concentric mixer shower. Please read them carefully. Read through the whole of this book before beginning your installation.

The shower installation must be carried out by a suitably competent person and in sequence of this instruction book.

Care taken during the installation will give a long and trouble free life from your shower.

For the best performance within the specified running pressure range a minimum flow of 8 litres per minute should be available to both inlets.

The mixer shower **MUST NOT** be subjected to water temperatures above 80°C.

This mixer shower is designed for use with traditional low pressure 'gravity' water systems, using a cold water cistern and hot water cylinder as well as for the higher pressure systems found in the UK up to a maximum of 5 bar running pressure.

IMPORTANT: The supplied flow limiter **MUST** be installed in the outlet adaptor.

This mixer shower is suitable for fully modulating type combination boilers and multi-point hot water heaters. Also suitable for thermal storage, unvented systems and pumped gravity systems.

IMPORTANT: Before installing with a gas instantaneous water heater, make sure it is capable of delivering hot water at a minimum switch-on flow rate of 3 litres per minute.

At flow rates between 3 and 8 litres per minute, the appliance must be capable of raising the water temperature to a minimum of 52°C. Water temperature at the mixer inlet must remain relatively constant when flow rate adjustments are made (*refer to the water heater operating manual to confirm compatibility with this mixer shower*).

This mixer shower is supplied with a check valve in each inlet elbow. Inlet connections are by compression fittings for 15mm copper pipe.

SAFETY WARNINGS

- a. Layout and sizing of pipework must be such that when other services are used, pressures at the shower control inlets do not fall below the recommended minimum.
- b. **DO NOT choose a position where the shower could become frozen.**
- c. **DO NOT connect this mixer shower to any form of tap or fitting not recommended by the manufacturer.**
- d. The showerhead must be regularly cleaned to remove scale and debris.
- e. Conveniently situated isolating valves in each inlet supply must be fitted as an independent method of isolating the shower should maintenance or servicing be necessary.
- f. If it is intended to operate the shower in areas of hard water (above 200 ppm temporary hardness), a scale inhibitor may have to be fitted. For advice on the Triton scale inhibitor, please contact Customer Service.
- g. **DO NOT operate the shower outside the guidelines as laid out in 'site requirements'.**

Replacement parts can be ordered from Triton Customer Service. See 'spare parts' for details and part numbers.

Due to continuous improvement and updating, specification may be altered without prior notice.

MAIN COMPONENTS

Fig.1

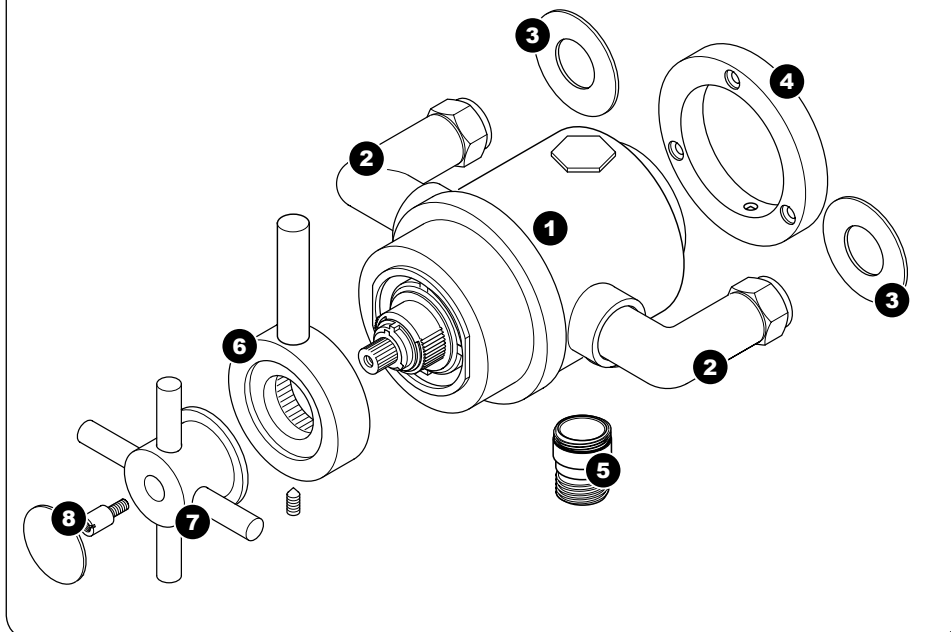

1. Mixer shower body
2. Inlet elbow including:
 - Inlet nut
 - Olive
 - Check valve
3. Rear pipe trim
4. Fixing bracket
5. Outlet adaptor
6. Flow control handle
7. Temperature control handle
8. Retaining screw and trim
 - Flow limiter

SITE REQUIREMENTS

The installation must be in accordance with Water Regulations and Byelaws.

Running water pressure:

Gravity fed – 0.1 bar min.
1.0 bar max.

Mains fed – 1.0 bar min.
5.0 bar max.

Maximum static water pressure:

Gravity and mains – 10 bar

DO NOT connect the mixer shower to a gravity hot supply and a mains cold supply (or vice versa).

For the best performance within the specified running pressure range a minimum flow of eight litres per minute should be available to both inlets.

While the mixer shower is operational (open outlet), inlet pressures must not be capable of exceeding 7 bar. For effective operation of the internal seals, the maximum static pressure must not be exceeded.

Note: On sites where the running pressure is above 5 bar, the use of a suitably sized pressure reducing valve fitted in the cold mains supply pipework can provide nominally equal pressures at the mixer shower.

The pipework should be installed such that the flow is not significantly affected by other taps and appliances being operated elsewhere on the premises.

Note: Where thermal store systems and instantaneous gas water heaters are used, if excessive draw offs take place the boiler may not be able to maintain an adequate output temperature. This could result in the shower temperature becoming noticeably cooler.

Water temperature requirements

Maximum hot water temperature = 80°C

Recommended maximum = 65°C

Minimum hot water temperature = 52°C

Maximum cold water temperature = 20°C

BS6700 recommends that the temperature of stored water should never exceed 65°C.

A stored water temperature of 60°C is considered sufficient to meet all normal requirements and will minimise the effects of scale in hard water areas.

Temperature adjustment range

The mixed water temperature can be adjusted from cold through to a top limit which must be pre-set during installation with full anti-scald protection throughout the range (35°C to 40°C) providing the hot water temperature at the inlet remains 10°C above the outlet temperature.

Should there be a loss of flow to either incoming supply then water from the shower will stop or be reduced to a trickle until both supplies are restored.

Fig.2 (diagrammatic view – not to scale)

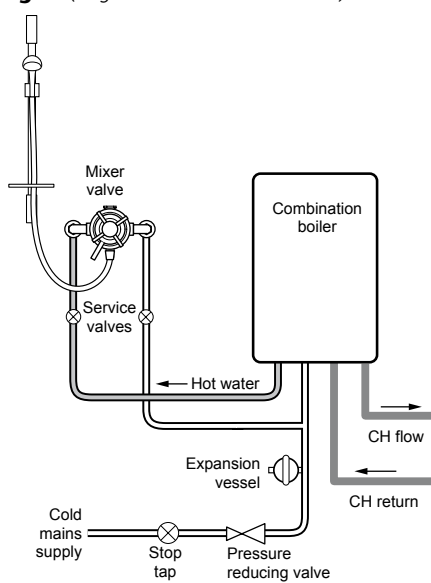

TYPICAL SUITABLE INSTALLATIONS

a) Instantaneous gas-heated systems, e.g. combination boilers (fig.2)

The shower control must be installed with a multipoint gas water heater or combination boiler of a fully modulating design (i.e. to maintain relatively stable hot water temperatures).

A drop tight pressure reducing valve must be fitted if the supply pressures exceed 5 bar running.

An expansion vessel, shown in (fig.2), MUST be fitted, and regularly maintained, to ensure the shower mixer is not damaged by excess pressures. This may already be installed within the boiler (check with manufacturer) and is in addition to the normally larger central heating expansion vessel.

The layout and sizing of pipework MUST be such that nominally equal inlet supply pressures are achieved and the effects of other draw-offs are minimised. The hot supply temperature MUST remain a minimum of 10°C hotter than the required blend temperature for best performance.

b) Unvented mains pressure systems (fig.3)

The shower control can be installed with an unvented, stored hot water cylinder.

For systems with no cold water take off after the appliance reducing valve, it will be necessary to fit an additional drop tight pressure reducing valve when the mains pressure is over 5 bar. The drop tight pressure reducing valve must be set at the same value as the unvented package pressure reducing valve.

Note: An additional expansion vessel (fig.3) may be required if a second pressure reducing valve is installed. This does not apply to packages with a cold take off after the pressure reducing valve to the cylinder.

The layout and sizing of pipework MUST be such that nominally equal inlet supply pressures are achieved and the effects of other draw-offs are minimised.

Fig.3 (diagrammatic view – not to scale)

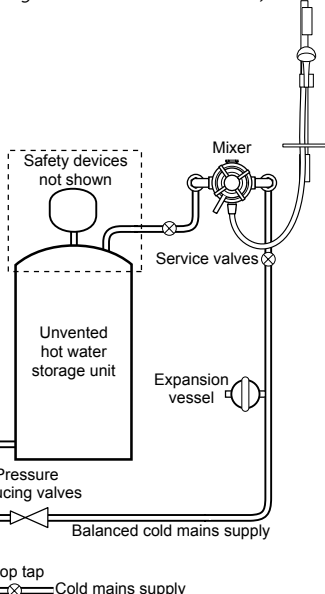

c) Mains pressurised thermal store systems (fig.4)

Packages of this type, fitted with a tempering valve (blender valve) can be used. A drop tight pressure reducing valve must be fitted if the supply pressures exceed 5 bar running.

An expansion vessel, shown in (fig.4), MUST be fitted, and regularly maintained, to ensure the unit is not damaged by excess pressures. This may already be installed externally or internally within the thermal store (check with thermal store manufacturer).

d) Gravity fed systems (fig.5)

The shower control MUST be fed from a cold water cistern and hot water cylinder providing nominally equal pressures. There must be a minimum of one metre head of water. The minimum head distance is measured from the base of the cold water cistern to top of the showerhead (fig.5).

e) Pumped gravity fed systems (fig.6)

The shower control can be used with a gravity fed system in conjunction with a suitable pump to boost pressures as shown (fig.6).

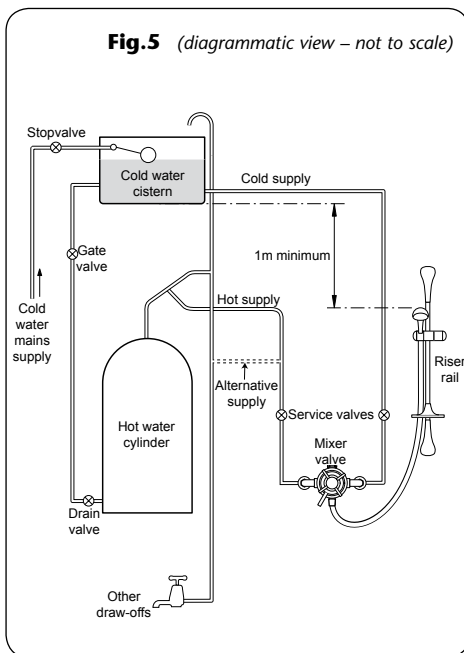
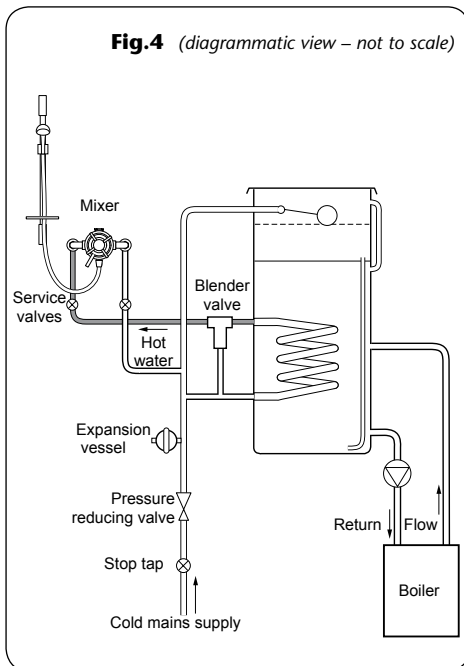

Fig.6 (diagrammatic view – not to scale)

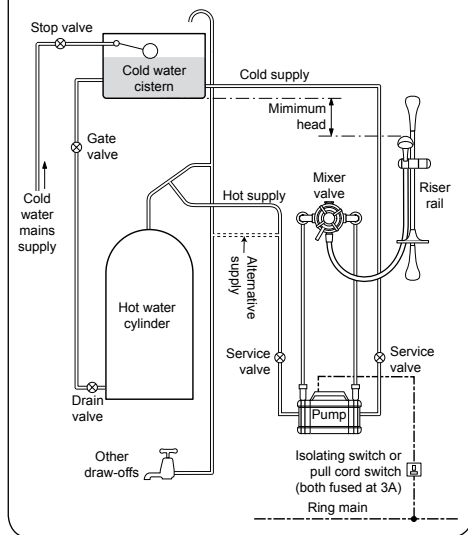
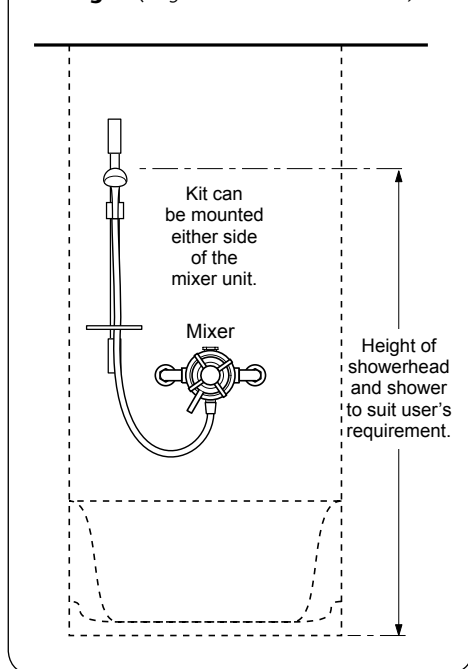

Fig.7 (diagrammatic view – not to scale)



GETTING STARTED

Check the contents to ensure all parts are present.

Before starting the installation, make all the openings on the mixer are carefully covered to prevent ingress of any debris, etc.

SITING OF THE SHOWER

WARNING!

The shower must not be positioned where it will be subject to freezing conditions.

Refer to (fig.7) for correct siting of the shower. Position the shower and showerhead on the wall so that all controls can be comfortably reached whilst using the shower. The showerhead and riser rail can be positioned either side of the shower.

IMPORTANT: The hot entry port is on the left-hand side of the mixer body marked by a 'HOT' label.

INSTALLATION

General conditions

If not already fitted, screw the flow handle into the flow control (fig.8).

Note: The outlet of the shower must not be connected to anything other than the hose and showerhead supplied.

DO NOT use jointing compounds on any pipe fittings for the installation. Use only the compression fittings supplied.

DO NOT solder fittings near the mixer unit as heat can transfer along the pipework and can damage seals and thermostatic components.

Note: Suitable isolating valves (complying with Water Regulations and Byelaws) MUST be fitted on the hot and cold water supplies to the shower as an independent means of isolating the water supplies should maintenance or servicing be necessary.

When connecting pipework avoid using tight 90° elbows. Swept or formed bends will give the best performance.

IMPORTANT: The water circuit should be installed such that the flow is not significantly affected by other taps and appliances being operated elsewhere on the premises. Water pressure must not fall below specification of the shower.

Hot water pipe entry MUST be made to the left-hand side inlet (fig.9).

The inlet elbows allow for either rising, falling or rear entry hot and cold water supplies. The elbows have 'O' seals (fig.10) to the body and do not require PTFE tape or other means of sealing.

IMPORTANT: To ensure satisfactory hot water temperature the supplied flow limiter **MUST** be installed in the outlet adaptor (fig.11).

Instantaneous Gas Water Heaters

In order to provide the best performance from the shower when connected to an instantaneous water heater, the appliance must be capable of raising the temperature of the incoming water to a minimum of 52°C (125°F) and delivering a flow rate of not less than eight litres per minute. With the flow limiter fitted and when the system is in use, the on/off flow control should be turned fully anti-clockwise to full flow setting.

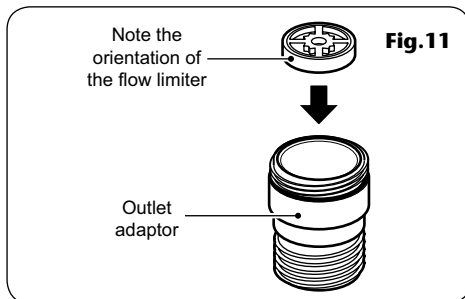
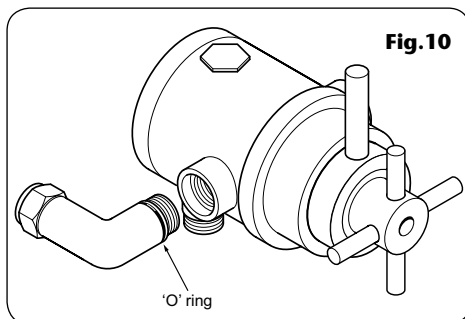
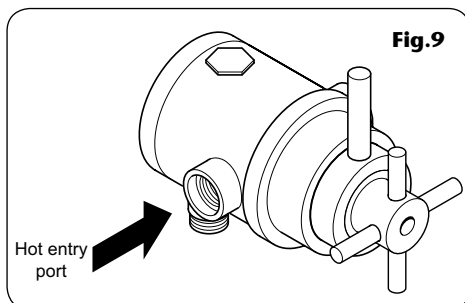
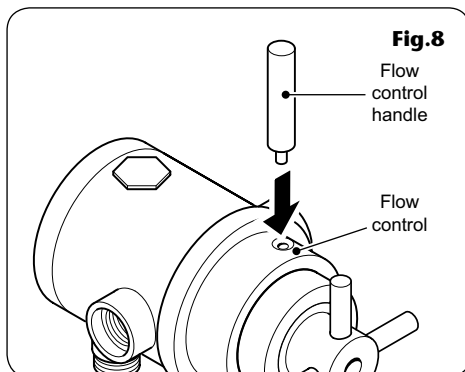

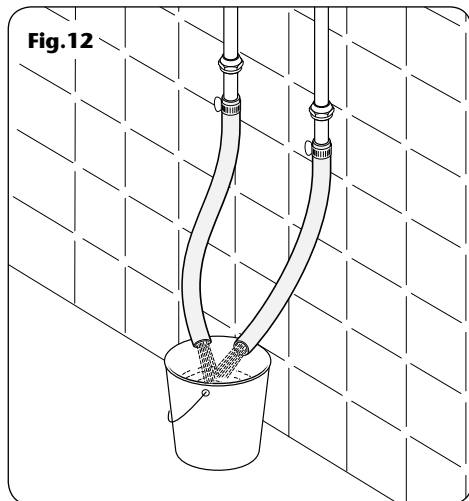

Fig. 12

RISING OR FALLING SUPPLIES

Complete the pipework to the shower area having decided on the position of the shower and direction of pipe entry.

The final separation between pipe centres needs to be between 150mm and 155mm. The hot and cold water pipes should not be permanently attached to the wall within one metre of the valve before installation to allow for final adjustment of the valve position.

Mark the position of the three locating screws for the fixing bracket.

It is preferable to flush the pipework (fig.12) to clear the system of debris and check for leaks before connecting to the mixer.

Drill and plug the holes using the wall plugs provided. *(The wall plugs provided are suitable for most brick walls — use an appropriate masonry drill, but if the wall is plasterboard or a soft building block, use special wall plugs and a suitable drill bit).*

Fit the mounting plate onto the wall using the screws supplied (**fig.13**).

Slide the inlet nut onto supply pipes followed by the olive.

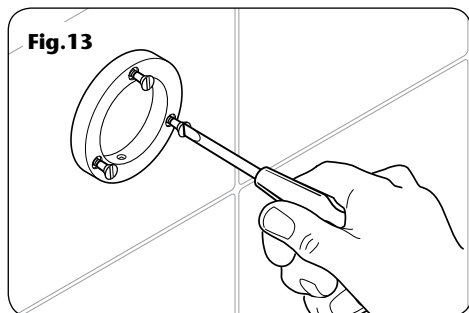

Fig. 13

REAR ENTRY SUPPLIES

Using a spirit level, mark the route of incoming hot and cold water supply pipes at a distance of 150mm – 155mm between centres. The hot and cold water pipes should not be permanently attached to the wall within one metre of the valve before installation to allow for final adjustment of the valve position.

Remove the plaster and brickwork to the required depth to conceal the supply pipework.

Note: Pipework installed in solid walls must be given enough free play inside a cavity to allow entry into the inlet elbows for tightening, before fixing the mixer unit to the finished wall surface.

Install the hot and cold pipework (hot pipe enters from the left), making sure that the finished pipework projects from the front face of the tiled surface of the wall by about 30 – 35 mm (**fig.14**).

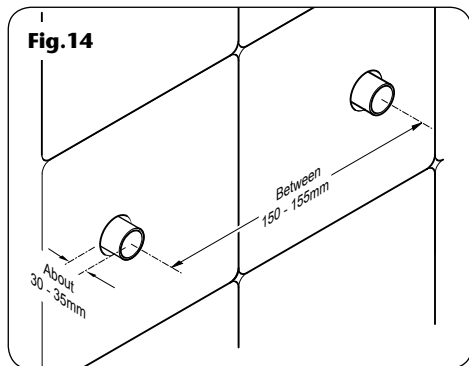

Fig. 14

Make good the wall and complete the tiling. Mark the three fixing holes. Drill and plug the holes using the wall plugs provided. Fit the mounting plate onto the wall using the screws provided (**fig.13**).

FITTING THE MIXER

IMPORTANT: Flush the pipework to clear the system of debris and check for leaks before connecting to the mixer.

Slide the trims and inlet nuts onto the supply pipes followed by the olive (**fig.15**).

Offer the mixer to the pipework and mounting plate. Make sure that the mixer body grub screw is slack, allowing the body to move freely on the mounting plate.

Level the mixer and tighten the grub screw to secure to the mounting plate. Tighten the inlet nuts.

LEAK TESTING

Fit a hose to the outlet and direct it to waste. Turn the flow control fully clockwise to close it. Open the isolating valves to the shower. Open the flow control by turning fully anti-clockwise and flush through.

Turn the temperature control fully anti-clockwise (HOT) and then fully clockwise (COLD).

Turn the flow control fully clockwise to close off the water supply.

Check for any leaks and remedy if necessary.

Turn OFF the water supplies

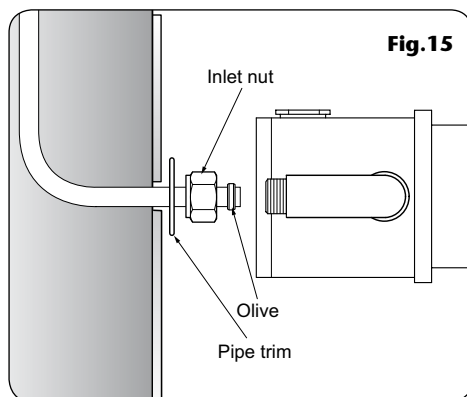

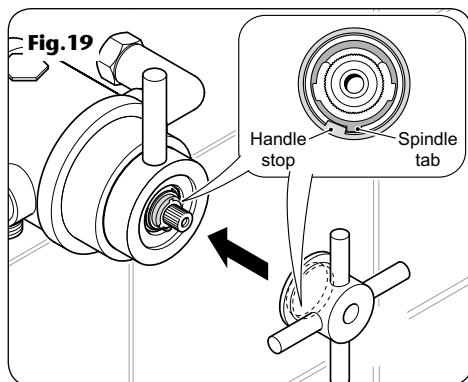
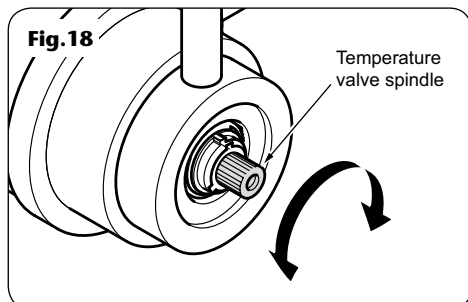
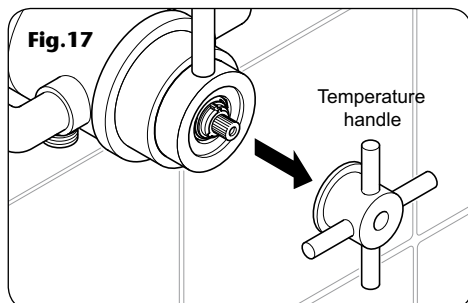
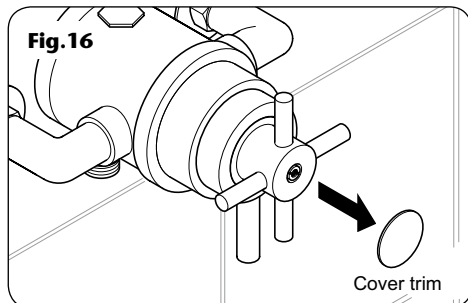

COMMISSIONING

IMPORTANT: Make sure that all supply pipework has been flushed through before commissioning.

Make sure that both hot and cold water supplies are fully open and their design temperature and pressures and are within the requirements as stated.

Make sure the temperature control is at the maximum temperature setting, i.e. rotated fully anti-clockwise and the showerhead is directed to waste.

Start the water flow by turning the flow control anti-clockwise. Allow the shower to run at the maximum temperature setting until the water temperature has stabilised. Rotate the temperature control anti-clockwise until the desired maximum showering temperature is reached.

The mixers have a temperature stop to prevent accidental rotation to higher temperatures. This is adjustable to provide a maximum temperature of 35°C – 45°C.

ADJUSTING THE MAXIMUM TEMPERATURE SETTING

To remove the temperature handle first unscrew the cover trim to expose the retaining screw (**fig. 16**). With a suitable screwdriver, unscrew the retaining screw and pull off the temperature handle (**fig. 17**).

Turn the flow control fully anti-clockwise. With a steady flow running, adjust the temperature valve spindle by hand until the desired temperature is reached (**fig. 18**).

Carefully refit the temperature control so that the stop on the inside of the temperature handle butts up to the tab on the valve (**fig. 19**). Secure the handle in place with the retaining screw and replace the cover trim.

OPERATING THE SHOWER

To start the shower, rotate the flow control lever anti-clockwise for maximum flow (**fig.20**).

To stop the water flow, rotate the flow control lever clockwise (**fig.20**).

To adjust the water temperature, rotate the temperature control — clockwise for a cooler shower or anti-clockwise for a hotter shower (**fig,21**).

CLEANING

WARNING!

DO NOT use 'powerful' abrasive or solvent cleaning fluids when cleaning the shower as they may damage the plastic fittings.

Before cleaning, turn off the unit at the isolation valve to avoid the shower being accidentally switched on.

IMPORTANT: DO NOT use abrasive or solvent cleaning fluids. The mixer unit should be cleaned using a soft cloth and warm water. Any stains should be removed using washing up liquid.

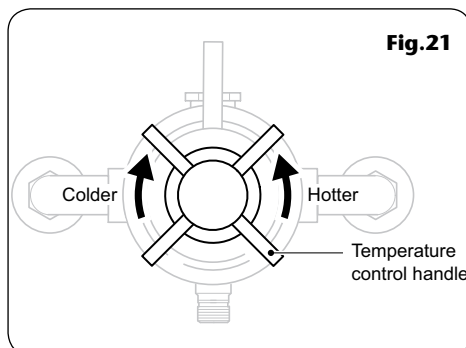
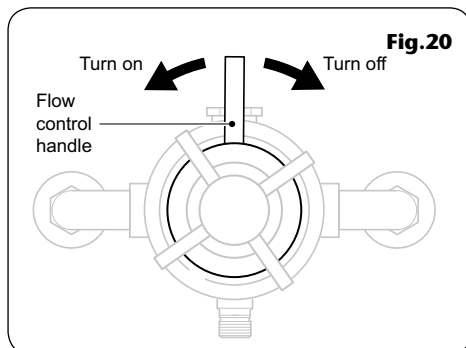

SPARE PARTS

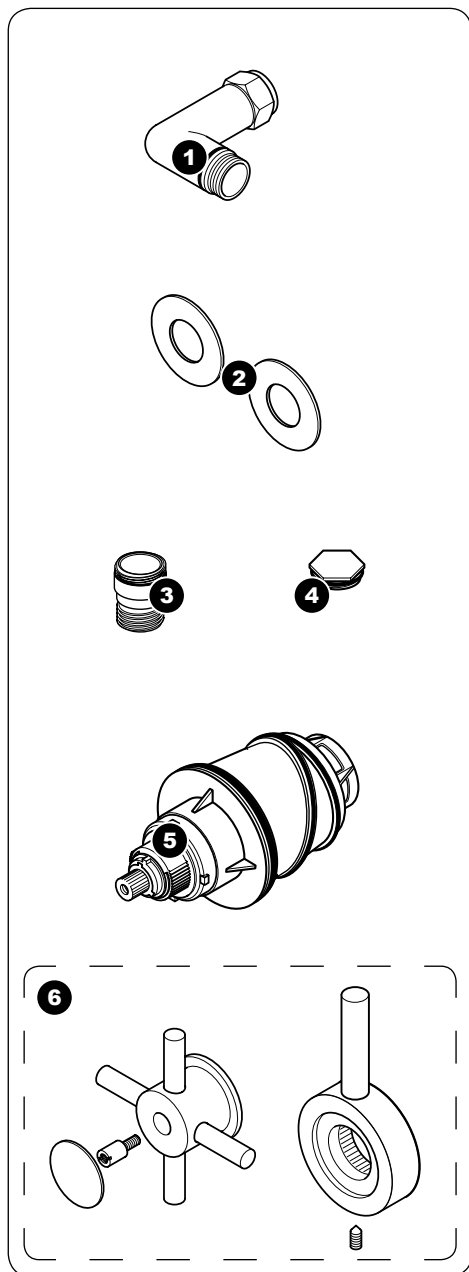

Ref.	Description	Part No.
1	Elbow assembly	83309550
2	Elbow trims (pair)	83309560
3	Outlet adaptor	83309570
4	Blanking plug	83309580
5	Thermostatic cartridge	88300000
6	Control handles w/ retaining screw and trim	86001740
-	Flow limiter	22011430

FAULT FINDING

The following can be carried out by a competent person

Problem/Symptom	Cause	Action/Cure
1 Water too hot.	1.1 Temperature control incorrectly commissioned.	1.1.1 Refer to commissioning section.
	1.2 Not enough cold water flowing through shower.	1.2.1 Turn temperature control clockwise.
	1.3 Increase in the ambient cold water temperature.	1.3.1 Turn temperature control clockwise.
	1.4 Cold water supply blocked.	1.4.1 Turn off shower and consult a competent plumber or contact Triton Customer Service.
	1.5 High volume of cold water drawn off elsewhere.	1.5.1 Reduce the simultaneous demand from the mains supply.
2 Water too cold.	2.1 Temperature control incorrectly commissioned.	2.1.1 Refer to commissioning section.
	2.2 Not enough hot water flowing through shower.	2.2.1 Turn the temperature control anti-clockwise.
	2.3 Decrease in the ambient cold water temperature.	2.3.1 Turn the temperature control anti-clockwise.
	2.4 Insufficient hot water supplies from the heating system.	2.4.1 Make sure heating appliance is set to maximum or has sufficient stored hot water.
	2.5 Hot water supply blocked or restricted.	2.4.2 Make sure the heating appliance is igniting by trying a hot water tap elsewhere.
	2.6 Flow limiter not fitted (HP systems only).	2.5.1 Turn off shower and consult a competent plumber or contact Triton Customer Service.
3 Water does not flow or shower pattern collapses when another outlet is turned on.	3.1 Water supplies cut off.	3.1.1 Check water elsewhere in house and if necessary contact local water company.
	3.2 Shower unit blocked.	3.2.1 Inspect the filters. Clean if necessary.
	3.3 Blockage in pipework.	3.3.1 Turn the shower off and consult a suitably competent plumber.
	3.4 Showerhead blocked.	3.4.1 Clean showerhead.
	3.5 System not capable of supplying multiple outlets at the same time.	3.5.1 Reduce the simultaneous demand.
		3.5.2 Make sure stop or service valve is fully open.
		3.5.3 Check if sufficient water pressure.

FAULT FINDING

The following is recommended for a professional qualified installer only

Problem/Symptom	Cause	Action/Cure
5 Water too cold.	5.1 Running pressure in excess of maximum recommended.	5.1.1 Fit a pressure reducing valve.
6 Shower controls noisy when in use.	6.1 Running pressure in excess of maximum recommended.	6.1.1 Fit a pressure reducing valve.
7 Shower will not shut off.	7.1 Pipework not flushed before connecting the unit (seals damaged). 7.2 Seals damaged.	7.1.1 Renew thermostatic cartridge.



Service Policy

In the event of a complaint occurring, the following procedure should be followed:

- 1 Telephone Customer Service on 0870 067 3333 (0845 762 6591 in Scotland and in Northern Ireland), having available the model number and power rating of the product, together with the date of purchase.
- 2 Triton Customer Service will be able to confirm whether the fault can be rectified by either the provision of a replacement part or a site visit from a qualified Triton service engineer.
- 3 If a service call is required the unit must be fully installed for the call to be booked and the date confirmed. In order to speed up your request, please have your postcode available when booking a service call.
- 4 It is essential that you or an appointed representative (who must be a person of 18 years of age or more) is present during the service engineer's visit and receipt of purchase is shown.
- 5 A charge will be made in the event of an aborted service call by you but not by us, or where a call under the terms of guarantee has been booked and the failure is not product related (i.e. scaling and furring, incorrect water pressure).
- 6 If the product is no longer covered by the guarantee, a charge will be made for the site visit and for any parts supplied.
- 7 Service charges are based on the account being settled when work is complete, the engineer will then request payment for the invoice. If this is not made to the service engineer or settled within ten working days, an administration charge will be added.

Replacement Parts Policy

Availability: It is the policy of Triton to maintain availability of parts for the current range of products for supply after the guarantee has expired. Stocks of spare parts will be maintained for the duration of the product's manufacture and for a period of five years thereafter.

In the event of a spare part not being available a substitute part will be supplied.

Payment: The following payment methods can be used to obtain spare parts:

- 1 By post, pre-payment of pro forma invoice by cheque or money order.
- 2 By telephone, quoting credit card (MasterCard or Visa) details.
- 3 By website order, www.tritonshowers.co.uk

TRITON STANDARD GUARANTEE

Triton guarantee this product against all mechanical defects arising from faulty workmanship or materials for a period of five years for domestic use only, from the date of purchase, provided that it has been installed by a competent person in full accordance with the fitting instructions.

Any part found to be defective during this guarantee period we undertake to repair or replace at our option without charge so long as it has been properly maintained and operated in accordance with the operating instructions, and has not been subject to misuse or damage.

This product must not be taken apart, modified or repaired except by a person authorised by Triton. This guarantee applies only to products installed within the United Kingdom and does not apply to products used commercially. This guarantee does not affect your statutory rights.

What is not covered:

- 1 Breakdown due to: *a*) use other than domestic use by you or your resident family; *b*) wilful act or neglect; *c*) any malfunction resulting from the incorrect use or quality of water or incorrect setting of controls; *d*) faulty installation.
- 2 Repair costs for damage caused by foreign objects or substances.
- 3 Total loss of the product due to non-availability of parts.
- 4 Compensation for loss of use of the product or consequential loss of any kind.
- 5 Call out charges where no fault has been found with the appliance.
- 6 The cost of repair or replacement of showerheads, hoses, riser rails and/or wall brackets or any other accessories installed at the same time.
- 7 The cost of routine maintenance, adjustments, overhaul modifications or loss or damage arising therefrom, including the cost of repairing damage, breakdown, malfunction caused by corrosion, furring, pipe scaling, limescale, system debris or frost.

Customer Service: ☎ 0870 067 3333

**Scottish and Northern Ireland
Customer Service:** ☎ 0845 762 6591

Trade Installer Hotline: ☎ 0870 067 3767
Fax: 0870 067 3334

www.tritonshowers.co.uk

E mail: technical@tritonshowers.co.uk

Triton Showers
Triton Road
Nuneaton
Warwickshire CV11 4NR

Triton is a division of Norcros Group (Holdings) Limited