

ASPIRANTE

TENERO

***Thermostatic dual
control mixer shower
(built-in)***



Installation and Operating Instructions

INSTALLERS PLEASE NOTE THESE INSTRUCTIONS ARE TO BE LEFT WITH THE USER

CONTENTS	Page
Introduction	1
Safety warnings	1
Main components	2
Site requirements	3
Typical installations	4 – 5
Instantaneous water heater appliance capabilities	6
Preparing the mixer valve	7
Siting of shower	7
Installation	8 – 10
Connecting the supply pipes	10
Fitting the bulkhead pipework	11
Making good	11
Fitting the bulkhead	12
Fitting the face plate and controls	13
Commissioning	14
Operating the shower	15
Cleaning	15
Cleaning the filters	15
Spare parts	16
Fault finding	17 – 18
Guarantee, service policy, etc.	rear cover

To check the product suitability for commercial and multiple installations, please contact Triton's specification advisory service before installation.

Telephone: +44 (0) 24 7632 5491

Facsimile: +44 (0) 24 7632 4564

E mail: technical@triton.plc.uk

INTRODUCTION

This book contains all the necessary fitting and operating instructions for your Aspirante Tenero thermostatic mixer shower. Please read them carefully. Read through the whole of this book before beginning your installation.

The shower installation must be carried out by a suitably competent person and in sequence of this instruction book.

Care taken during the installation will provide a long and trouble free life from your shower.

For best performance within the specified running pressure range a minimum flow of eight litres per minute should be available to both inlets.

The mixer shower MUST NOT be subjected to water temperatures above 80°C.

This mixer shower is designed for use with traditional low pressure 'gravity' water systems, using a cold water cistern and hot water cylinder as well as for the higher pressure systems found in the UK up to a maximum of 5 bar running pressure.

IMPORTANT: When installing this mixer with combination and multipoint hot water appliances, the supplied flow restrictor must be installed.

This mixer shower is suitable for fully modulating type combination boilers and multi-point hot water heaters. It is also suitable for thermal storage, unvented systems and pumped gravity systems.

IMPORTANT: Before installing with a gas instantaneous water heater, make sure it is capable of delivering hot water at a minimum switch-on flow rate of 3 litres per minute. At flow rates between 3 and 8 litres per minute, the appliance must be capable of raising the water temperature to a minimum of 52°C. Water temperature at the inlet to the mixer must remain relatively constant when flow rate adjustments are made (refer to the water heater operating manual to confirm compatibility with this mixer shower).

This mixer shower is supplied with an integral single check valve and integral large area filter in each inlet. Inlet connections are by 3/4" BSP to 22mm or 15mm compression (not supplied).

SAFETY WARNINGS

- a. Layout and sizing of pipework must be such that when other services are used, pressures at the shower control inlets do not fall below the recommended minimum.
- b. DO NOT choose a position where the shower could become frozen.
- c. DO NOT connect this mixer shower to any form of tap or fitting not recommended by the manufacturer.
- d. The shower head must be regularly cleaned to remove scale and debris.
- e. Conveniently situated service valves in each inlet supply must be fitted as an independent method of isolating the shower should maintenance or servicing be necessary.
- f. If it is intended to operate the shower in areas of hard water (above 200 ppm temporary hardness), a scale inhibitor may have to be fitted. For advice on the Triton scale inhibitor, please contact Customer Service.
- g. DO NOT operate the shower outside the guidelines as laid out in 'site requirements'.

Replacement parts can be ordered from Triton Customer Service. See 'spare parts' for details and part numbers.

Due to continuous improvement and updating, specification may be altered without prior notice.

MAIN COMPONENTS (fig.1)

Fig.1

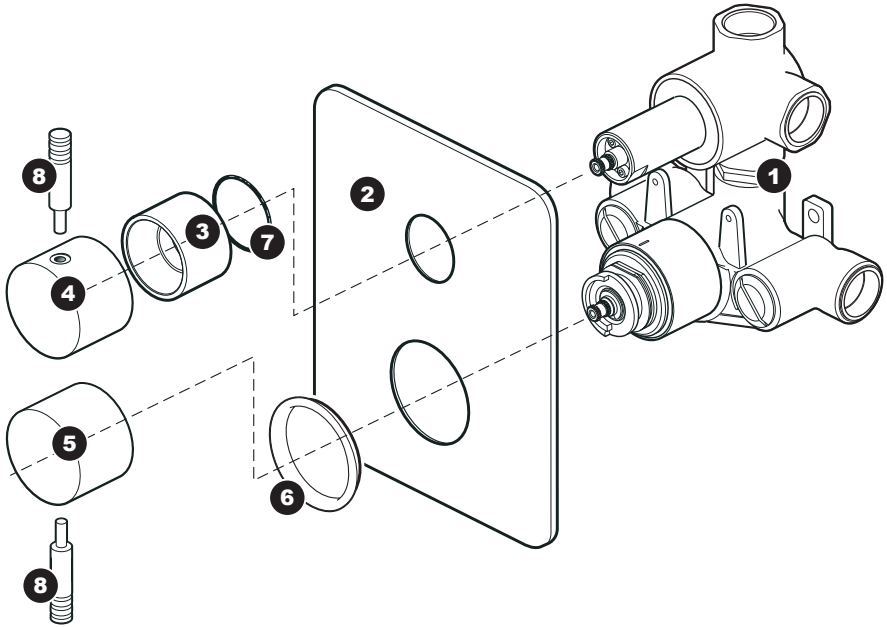

- 1** Mixer valve
- 2** Face plate
- 3** Threaded trim ring
- 4** On/off flow control
- 5** Temperature control
- 6** Rubber face plate seal
- 7** Trim ring seal
- 8** Control levers
- Screws
- Tiling shroud
- Shower head
- Riser rail assembly
- Flow limiters
- Fixing screws/wall plugs

SITE REQUIREMENTS

The installation must be in accordance with Water Regulations and Bylaws.

Running water pressure:

- Gravity fed — 0.1 bar min.
1.0 bar max.
- Mains fed — 1.0 bar min.
5.0 bar max.

Maximum static water pressure:

- Gravity and mains — 10 bar

DO NOT connect the mixer shower to a gravity hot supply and a mains cold supply (or vice versa).

For the best performance within the specified running pressure range a minimum flow of eight litres per minute should be available to both inlets.

While the mixer shower is operational (open outlet), inlet pressures must not be capable of exceeding 7 bar. For effective operation of the internal seals, the maximum static pressure must not be exceeded.

Note: On sites where the running pressure is above 5 bar, the use of a suitably sized pressure reducing valve fitted in the cold mains supply pipework can provide nominally equal pressures at the shower mixer.

The pipework should be installed such that the flow is not significantly affected by other taps and appliances being operated elsewhere on the premises.

Note: Where thermal store systems and instantaneous gas water heaters are used, if excessive draw offs take place the boiler may not be able to maintain an adequate output temperature. This could result in the shower temperature becoming noticeably cooler.

Water temperature requirements

Maximum hot water temperature = 80°C

Recommended maximum = 65°C

Minimum hot water temperature = 52°C

Maximum cold water temperature = 20°C

BS 6700 recommends that the temperature of stored water should never exceed 65°C.

A stored water temperature of 60°C is considered sufficient to meet all normal requirements and will minimise the effects of scale in hard water areas.

Temperature adjustment range

The mixed water temperature can be adjusted from cold through to a top limit which must be preset during installation with full anti-scald protection throughout the range (35°C to 40°C) providing the hot water temperature at the inlet remains 10°C above the outlet temperature.

Should there be a loss of flow to either incoming supply then water from the shower will stop or be reduced to a trickle until both supplies are restored.

Fig.2 (diagrammatic view — not to scale)

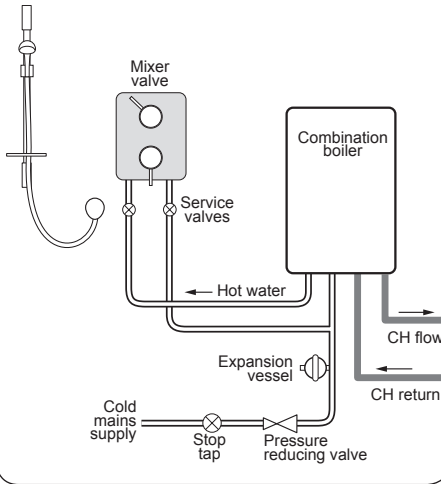

TYPICAL SUITABLE INSTALLATIONS

a) Instantaneous gas-heated systems, e.g. combination boilers (fig.2)

The shower control **MUST** be installed with a multipoint gas water heater or combination boiler of a fully modulating design (i.e. to maintain relatively stable hot water temperatures).

A drop tight pressure reducing valve **MUST** be fitted if the supply pressures exceed 5 bar running.

An expansion vessel (shown in **fig.2**) **MUST** be fitted, and regularly maintained, to ensure the shower mixer is not damaged by excess pressures. This may already be installed within the boiler (check with manufacturer) and is in addition to the normally larger central heating expansion vessel.

The layout and sizing of pipework **MUST** be such that nominally equal inlet supply pressures are achieved and the effects of other draw-offs are minimised. The hot supply temperature **MUST** remain a minimum of 10°C hotter than the required blend temperature for best performance.

b) Unvented mains pressure systems (fig.3)

The shower control can be installed with an unvented, stored hot water cylinder.

For systems with no cold water take off after the appliance reducing valve, it will be necessary to fit an additional drop tight pressure reducing valve when the mains pressure is over 5 bar. The drop tight pressure reducing valve must be set at the same value as the unvented package pressure reducing valve.

Note: An additional expansion vessel (**fig.3**) may be required if a second pressure reducing valve is installed. This does not apply to packages with a cold take off after the pressure reducing valve to the cylinder.

The layout and sizing of pipework **MUST** be such that nominally equal inlet supply

Fig.3 (diagrammatic view — not to scale)

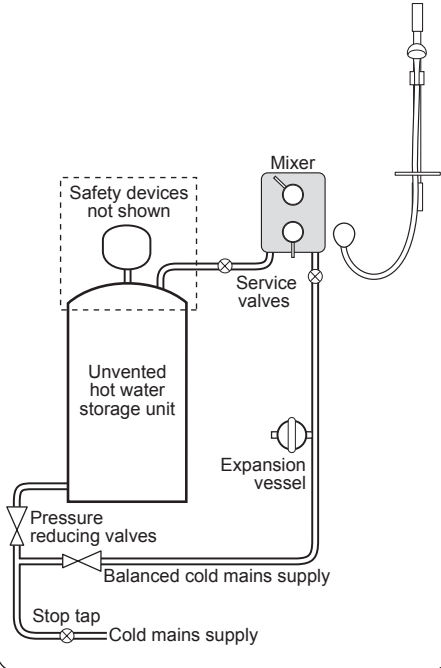

pressures are achieved and the effects of other draw-offs are minimised.

c) Mains pressurised thermal store systems (fig.4)

Packages of this type, fitted with a tempering valve (blender valve) can be used. A drop tight pressure reducing valve **MUST** be fitted if the supply pressures exceed 5 bar running.

An expansion vessel (shown in **fig.4**) **MUST** be fitted, and regularly maintained, to ensure the unit is not damaged by excess pressures. This may already be installed externally or internally within the thermal store (check with thermal store manufacturer).

d) Gravity fed systems (fig.5)

The shower control **MUST** be fed from a cold water cistern and hot water cylinder providing nominally equal pressures. There must be a minimum of one metre head of water. The minimum head distance is measured from the base of the cold water cistern to top of the shower head.

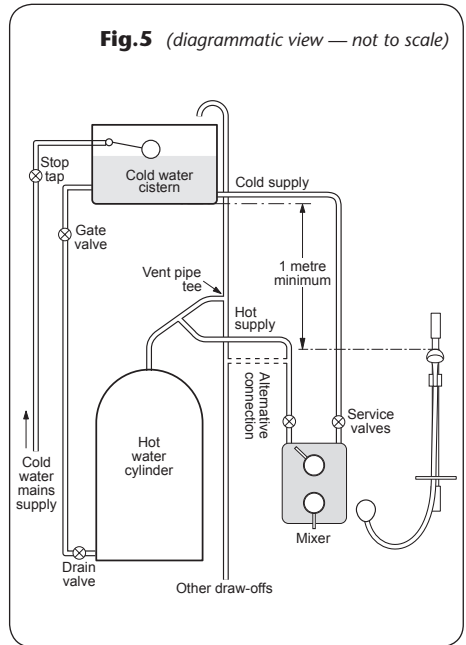
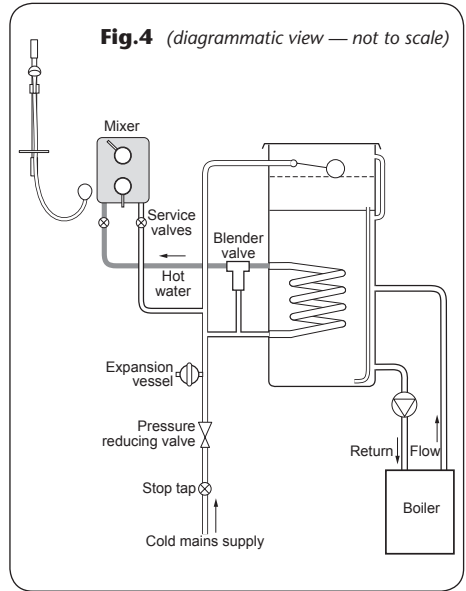

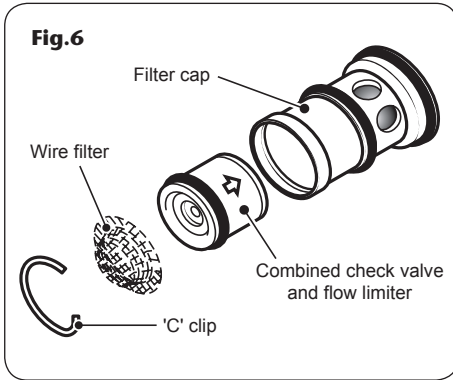

INSTANTANEOUS WATER HEATERS APPLIANCE CAPABILITIES

In order to ensure the best performance from the shower when connected to an instantaneous water heater, the appliance must be capable of raising the temperature of the incoming water to a minimum of 52°C (125°F) and delivering a flow rate of not less than eight litres per minute.

Flow limiters are supplied to control the maximum flow. To fit the flow limiters first remove the filter caps from the hot and cold inlets. Each filter cap contains a check valve and mesh debris filter, held in place by a 'C' clip (**fig.6**).

Carefully remove the 'C' clip and remove the filter and check valve. Replace the existing check valve with the combined check valve and flow limiter supplied.

IMPORTANT: When fitting the flow limiters note the correct facing.

Refit the mesh filter and secure in place with the 'C' clip.

Repeat the process for the other filter cap. Screw the filter caps back into the valve body.

With the flow limiters fitted and the system is in use, the on/off flow control should be turned fully anti-clockwise to full flow setting.

PREPARING THE MIXER VALVE

WARNING!

The shower must not be positioned where it will subject to freezing conditions.

Check the contents to make sure all parts are present.

Before beginning the mixer installation, make sure all the openings on the valve are carefully covered to stop ingress of any debris, etc.

The shower valve is suitable for installation in a chased out cavity in a solid wall, a stud partition wall, dry lined wall or fixing to a shower cubicle or panel.

The hot and cold water pipes should not be permanently attached to the wall within one metre of the valve before installation is complete to allow for final adjustment of the valve position.

Note: Suitable service valves (complying with Water Regulations and Bylaws) **MUST** be fitted on the hot and cold water supplies to the shower as an independent means of isolating the water supplies should any maintenance or servicing be necessary.

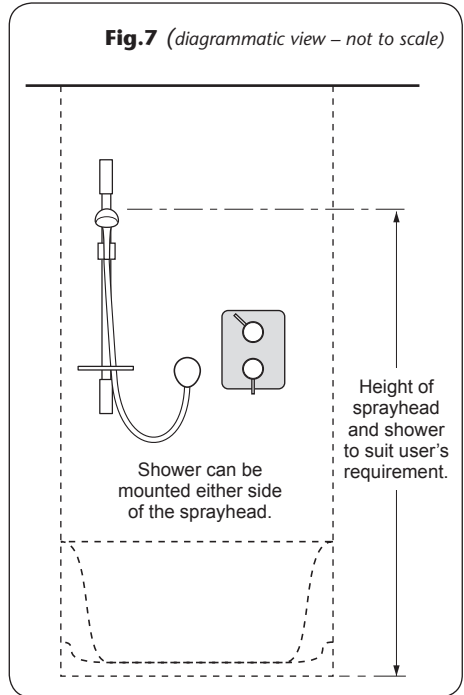

SITING OF THE SHOWER

Refer to **fig.7** for correct siting of the shower.

Position the shower and shower head on the wall so that all controls can be comfortably reached while using the shower. The shower head can be positioned either side of the shower.

The unit must be positioned vertically with the outlet port at the top (marked with an 'arrow' on the brass body).

IMPORTANT: The hot entry port is stamped 'HOT' on the mixer body.

Fig.8

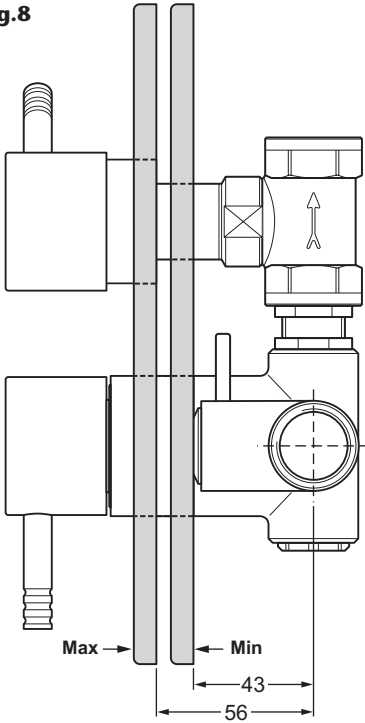
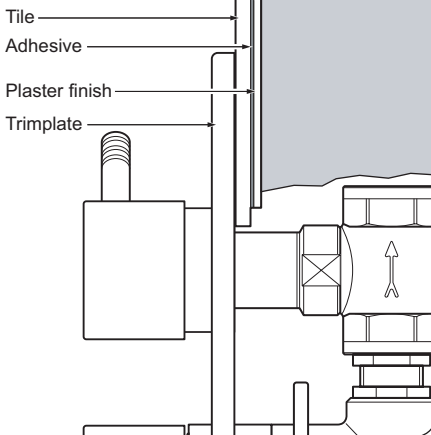

Fig.9



INSTALLATION

a) General conditions

Note: The outlet of the shower MUST NOT be connected to anything other than the shower head supplied.

DO NOT use jointing compounds on any pipe fittings for the installation.

Suitable $\frac{3}{4}$ " BSP to 22mm or 15mm compression fittings (not supplied) MUST be used for connecting to the water supplies.

DO NOT solder fittings near the mixer unit as heat can transfer along the pipework and damage the seals and thermostatic components.

When connecting the pipework, avoid using tight 90° elbows. Swept or formed bends will give the best performance.

The hot water inlet is stamped 'HOT' and the cold water inlet is identified 'COLD'.

$\frac{3}{4}$ " BSP straight or elbow male thread couplers must be fitted to the inlet ports for either rising, rear or falling hot and cold water supplies.

A $\frac{3}{4}$ " BSP straight coupler needs to be fitted to the valve outlet.

Note: These couplers are NOT supplied.

Screw the couplers into the inlets and the outlet of the valve. THE COUPLERS MUST BE TIGHTENED AGAINST THE VALVE BODY. The fittings will require PTFE tape or other means of sealing.

Before installing, make sure the typical available depth of the recess or cavity is at least 65mm when measured from the finished surface.

The allowance for varying thickness of tiles up to 10mm is accommodated to a limited degree by the tolerance between the control knobs and trim ring (**fig.8**).

The following are typical thicknesses and are given as a guide only (**fig.9**):

Tile	6 – 10 mm
Adhesive	2 – 3 mm
Plasterboard	9.5 – 12.5 mm
Plaster finish	2 – 3 mm

The maximum tile thickness should be no greater than 10mm.

b) Installation in a solid wall

Decide on the shower position and determine whether the hot and cold water supplies will enter the shower from the top (falling) or bottom (rising) or rear.

As a guide for the size of hole, it should be large enough to accept the valve complete with the inlet and outlet fittings and also allow access for connection to the pipework (**fig.10**).

Remove the plaster and brickwork to the required depth and chase out any additional areas of the wall to give access to the pipework to and from the valve. Note that the valve body requires a deeper recess than the inlet and outlet fittings.

Offer the valve body up to the wall and mark the two fixing holes. Remove the valve and drill and plug the wall. Route the pipework to valve body position.

Flush out the pipework in accordance with Water Regulations and Bylaws.

Offer the valve to the pipework and secure with screws through the two fixing brackets on the valve body.

Proceed to 'connecting supply pipes' section.

c) Installation in a hollow wall

Decide on the shower position and determine whether the hot and cold water supplies will enter the shower from the top (falling) or bottom (rising) or rear.

When installing into a stud partition or other hollow wall structures, the installer will need to consider fabricating rear supports or other options. Such options are beyond the scope of this guide.

Mark the route of the incoming and outgoing pipework.

Take out the plasterboard (use the tiling shroud as a template). Offer the valve body up to the fabrication and mark the two fixing holes.

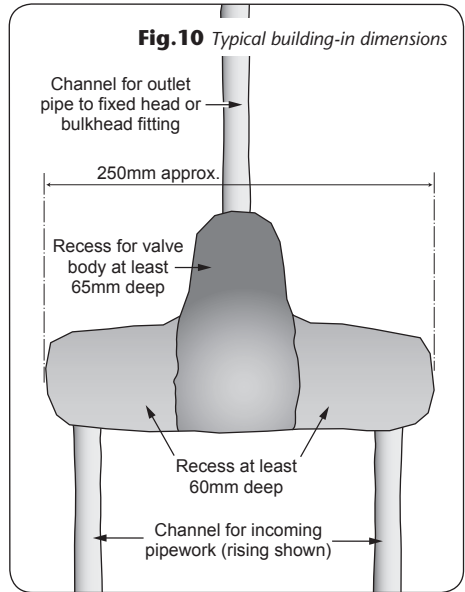

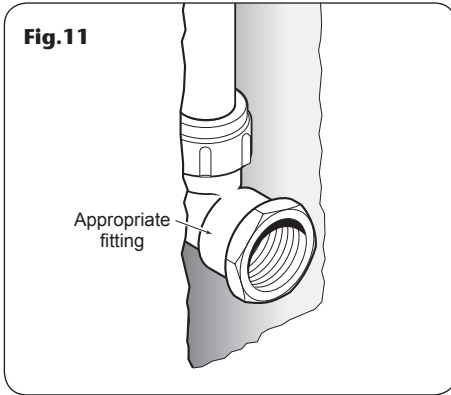

Remove the valve and drill the holes. Route the pipework to the valve position.

Flush out the pipework in accordance with Water Regulations and Bylaws.

Offer the valve up to the pipework and secure with screws through the two fixing brackets on the valve body.

Proceed to '*connecting supply pipes*' section.

d) Installation in a panel or cubicle

When installing into a panel or cubicle structure the installer will need to consider fabricating rear supports or other options. Such options are beyond the scope of this guide.

Typically, there should be at least 65mm space from the surface of the panel to the rear of the valve body.

IMPORTANT: Access to the rear of the valve must be available.

Decide on the shower position and determine whether the hot and cold water supplies will enter the shower from the top (falling) or bottom (rising) or rear. Mark the route of the incoming and outgoing pipework.

The controls require two holes to be cut out of the panel or cubicle. Use the face plate as a template to mark the hole positions then extend further to allow access for the filters (use the tiling shroud as a template).

Route the pipework to valve position.

Flush out the pipework in accordance with Water Regulations and Bylaws.

Offer the valve up to the pipework and secure to the fabrication with screws through the two fixing brackets on the valve body.

CONNECTING SUPPLY PIPES

Connect the hot water supply to the inlet marked 'HOT' and connect the cold water supply to the inlet marked 'COLD'.

Tighten all compression fittings.

FITTING THE BULKHEAD PIPEWORK

Complete the outlet pipework ending in a ½" BSP x 15mm female thread elbow or straight coupler (**fig.11**).

Note: This fitting is not supplied as variations in installations require the selection of the most suitable fitting.

Screw the supplied male-thread connector into the female fitting (**fig.12**) using PTFE tape to provide a watertight joint.

Note: The male-thread connector supplied has a shoulder. If fitting into a flush wall, make an extra 8mm allowance for this shoulder at the finished surface. The connector can be cut to size if required.

The threaded connector should protrude from the wall surface between 8mm and 13mm.

Fit a hose to the bulkhead threaded connector and direct it to waste.

Make sure the flow control spindle is in the OFF position by temporarily fitting the flow control lever and turning clockwise until resistance is felt. Open the supplies and test for leaks in all pipework upstream of the valve.

Turn on the flow control lever and test for leaks to the bulkhead outlet. Remedy any leaks if necessary. Turn off the water supplies.

MAKING GOOD

Fit the supplied tiling shroud over the mixer body and make good the wall, tiling, etc. and around the bulkhead outlet.

Plaster or tile up to the edge of the shroud.

Note that if the tiles are accurately cut to match the profile of the shroud, then the face plate will seal around the hole in the tiles, and the valve unit can be serviced without the need to break any tiles.

Make sure the grout lines are flush with the tiles to provide a smooth sealing surface for the face plate.

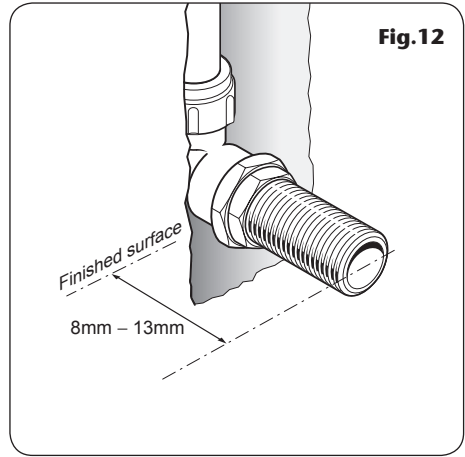
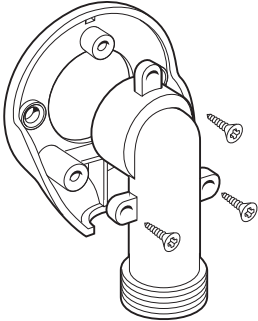

Fig. 13



FITTING THE BULKHEAD

The bulkhead and its cover are supplied assembled. Separate the two halves by carefully prising apart at the smaller of the two elbow apertures.

Secure the elbow to the bulkhead body with the three screws supplied (**fig. 13**).

Screw temporarily the bulkhead assembly onto the threaded connector. Mark the position of the two fixing holes (**fig. 14**) for securing the bulkhead to the wall.

Note: If screw thread protrudes too far out of the wall, it can be cut to the correct length using a hacksaw.

Unscrew and remove the bulkhead assembly. Check the location of the pipe in the wall before drilling. Drill and plug the holes using the wall plugs supplied. (*The wall plugs provided are suitable for most brick walls — use an appropriate masonry drill, but if the wall is plasterboard or a soft building block, you must use suitable wall plugs and a suitable drill bit*).

If fitting to a hollow wall structure, it may be preferable to secure the bulkhead by applying a bead of silicon seal to the back of the bulkhead.

Apply PTFE tape to the threaded connector.

Screw the bulkhead assembly onto the threaded connector until tight to the wall and the two fixing holes are aligned. Secure to the wall with the two screws supplied (**fig. 15**).

Finish by clipping the cover onto the bulkhead making sure the protruding legs locate in the bulkhead body.

Fig. 14

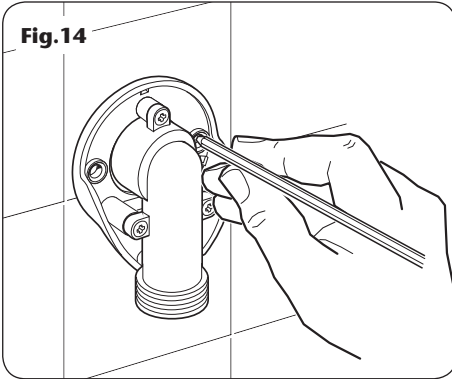
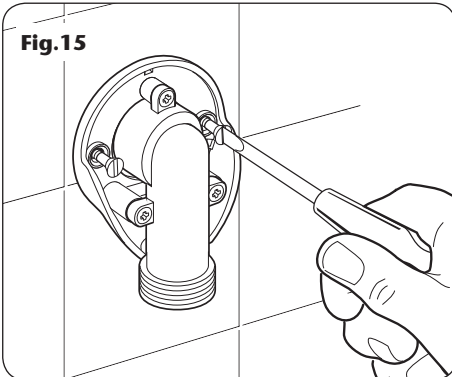

Fig. 15



FITTING THE FACE PLATE AND CONTROLS

Insert the rubber face plate seal into the temperature opening (**fig.16**). Fit the face plate over the protruding controls and slide tight to the wall. Make sure the rubber seal in the temperature opening stays in place as it slides over the trim. A smear of liquid soap on the seal will ease this procedure.

The face plate incorporates a silicon sponge backing that seals against a smooth wall.

On/off flow control knob assembly

Insert the trim ring seal into the recess on the back of the threaded trim ring (**fig.17**). Screw the threaded trim ring onto the flow control spindle until it engages into the face plate opening.

Fit the flow control knob onto the spindle (**fig.18**). Secure to the spindle using the grub screw.

Screw the lever into the control.

Note: Lever should rotate between 'ON' and 'OFF' indications on the face plate.

Temperature control knob assembly

Fit the temperature control onto the splined adaptor.

Note: The temperature control is identified as having an indicator line on the edge and a stop pin on the inside.

DO NOT secure with the grub screw until the commissioning procedure is complete.

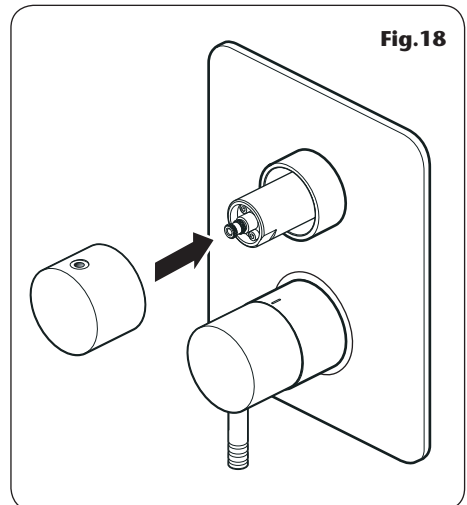
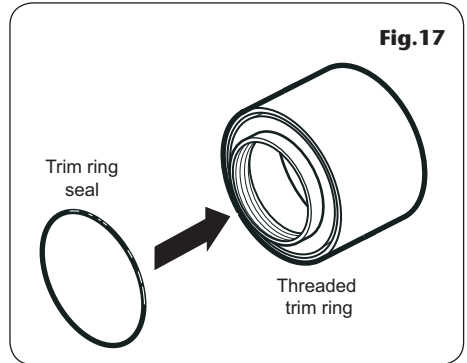
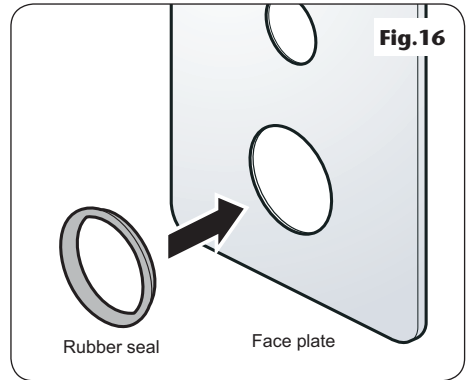

Fig.19

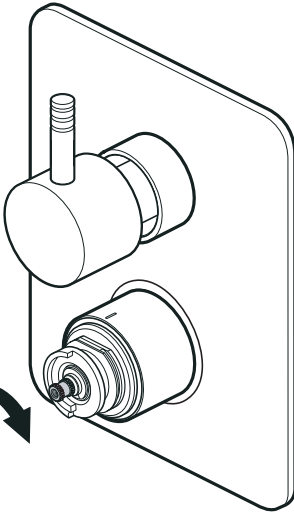
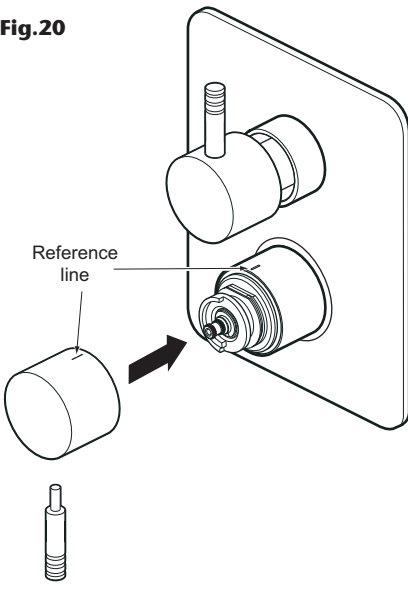

Fig.20



COMMISSIONING

CHECK THAT ALL SUPPLY PIPEWORK HAS BEEN FLUSHED THROUGH BEFORE COMMISSIONING.

Make sure that both hot and cold water supplies are fully open and at (or near to) their design temperature and pressures and are within the requirements as stated.

Make sure the temperature knob is rotated fully anti-clockwise (maximum temperature setting).

Make sure the shower head is directed to waste.

Start the water flow by turning the flow control anti-clockwise towards 'ON'.

Allow the shower to run at the maximum temperature setting until the water temperature has stabilised. Using the temperature control knob, rotate until your desired maximum showering temperature is reached.

The mixer valve is factory set to provide a maximum outlet temperature of 38°C but this should be checked on site to make sure the setting has not been altered and also to ensure user safety.

Adjusting the maximum temperature stop

Unscrew the temperature control lever to allow access to the retaining grub screw inside. Using a suitable Allen key, loosen the grub screw and remove the temperature control.

Turn the flow control fully anti-clockwise. With a steady flow running, adjust the temperature spindle (**fig.19**) until the temperature is about 38°C (turn clockwise for hotter or anti-clockwise for cooler).

When the showering temperature is satisfactory turn off the shower. Refit the temperature control, making sure the line on the temperature control aligns with the reference line in the mixer body (**fig.20**). Secure in place with the grub screw and refit the temperature control lever.

OPERATING THE SHOWER

To start the shower, rotate the flow control lever fully to the left for maximum flow.

To stop the water flow, rotate the flow control lever fully to the right.

To adjust the water temperature, rotate the temperature control — clockwise for a cooler shower or anti-clockwise for a hotter shower.

CLEANING

When the controls and face plate require cleaning, care must be taken not to scratch them in the process. Wash away any surface dust before cleaning with soapy water.

CLEANING THE FILTERS

Turn off the water supplies before proceeding.

To gain access to the filters remove the two levers and control knobs. Now remove the threaded trim ring then pull the face plate away from the wall.

Unscrew the filter cap (**fig.21**) on each inlet, unclip the 'C' clip and remove the filter. Wash the filter thoroughly under running water to remove all debris. Replace the filter and 'C' clip into the cap and screw the unit back into each inlet, making sure the 'O' ring is in place.

Reassemble the face plate, controls and levers.

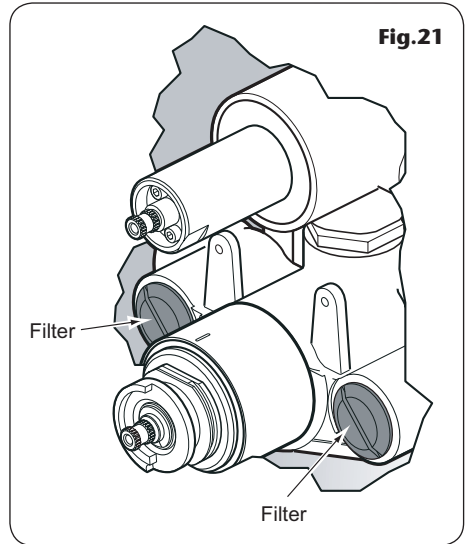

SPARE PARTS

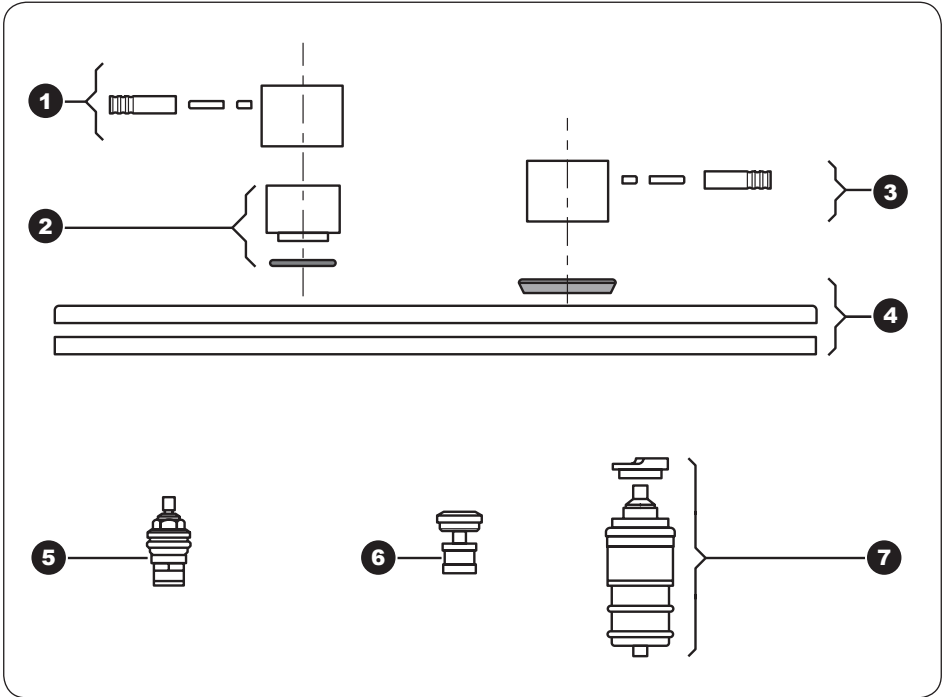

Ref	Description	Part No.
1.	Closure control knob	83307640
2.	Adaptor	83307230
3.	Regulation control knob	83307650
4.	Face plate	83301490
5.	Thermostatic cartridge	83307250
6.	Ceramic headworks	83307220
7.	Non-return valve	83307240
-	Flow limiter	22011290

FAULT FINDING

The following can be carried out by a competent person

Problem/Symptom	Cause	Action/Cure
1 Water too hot.	1.1 Temperature control incorrectly commissioned.	1.1.1 Refer to 'commissioning' section.
	1.2 Not enough cold water flowing through shower.	1.2.1 Turn temperature control anti-clockwise.
	1.3 Increase in the ambient cold water temperature.	1.3.1 Turn temperature control anti-clockwise.
	1.4 Cold water supply blocked.	1.4.1 Turn off shower and consult a competent plumber or contact Triton Customer Service.
	1.5 High volume of cold water drawn off elsewhere.	1.5.1 Reduce the simultaneous demand from the supply.
2 Water too cold.	2.1 Temperature control incorrectly commissioned.	2.1.1 Refer to 'commissioning' section.
	2.2 Not enough hot water flowing through shower.	2.2.1 Turn the temperature control clockwise.
	2.3 Decrease in the ambient cold water temperature.	2.3.1 Turn the temperature control clockwise.
	2.4 Insufficient hot water supplies from the heating system.	2.4.1 Make sure heating appliance is set to maximum or has sufficient stored hot water. 2.4.2 Make sure heating appliance is igniting by trying a hot water tap elsewhere.
	2.5 Hot water supply blocked or restricted.	2.5.1 Turn off the shower and consult a competent plumber or contact Triton Customer Service.
	2.6 Flow limiter not fitted (HP systems only).	2.6.1 Fit the supplied flow limiters in the filter caps (see 'instantaneous water heaters appliance capabilities').
3 High water flow and/or poor performance on a mains fed system.	3.1 Flow limiter not fitted.	3.1.1 Fit the supplied flow limiters in the filter caps (see 'instantaneous water heaters appliance capabilities').

FAULT FINDING

The following can be carried out by a competent person

<i>Problem/Symptom</i>	<i>Cause</i>	<i>Action/Cure</i>
4 Water does not flow or shower pattern collapses when another outlet is turned on.	4.1 Water supplies cut off.	4.1.1 Check water elsewhere in house and if necessary contact local water company.
	4.2 Shower unit blocked.	4.2.1 Inspect the inlet filters. Clean if necessary.
	4.3 Blockage in pipework.	4.3.1 Turn off the shower and consult a suitably competent plumber.
	4.4 Shower head blocked.	4.4.1 Clean the shower head.
	4.5 System not capable of supplying multiple outlets at the same time.	4.5.1 Reduce the simultaneous demand. 4.5.2 Check stop/service valves are fully open. 4.5.3 Check if sufficient water pressure.
5 Water too cold.	5.1 Running pressure in excess of maximum recommended.	5.1.1 Fit a pressure reducing valve.
6 Shower controls noisy while in use.	6.1 Running pressure in excess of maximum recommended.	6.1.1 Fit a pressure reducing valve.
7 Shower will not shut off.	7.1 Pipework not flushed through before connecting the unit (flow control damaged).	7.1.1 Renew flow control ceramic headworks.



*A **NORGROS** Company*

Service Policy

In the event of a complaint occurring, the following procedure should be followed:

- 1** Telephone Customer Service on +44 (0) 24 7637 2222 (+44 (0) 84 5762 6591 in Scotland and in Northern Ireland), having available the model number and power rating of the product, together with the date of purchase.
- 2** Triton Customer Service will be able to confirm whether the fault can be rectified by either the provision of a replacement part or a site visit from a qualified Triton service engineer.
- 3** If a service call is required it will be booked and the date of call confirmed. In order to speed up your request, please have your postcode available when booking a service call.
- 4** It is essential that you or an appointed representative (who must be a person of 18 years of age or more) is present during the service engineer's visit and receipt of purchase is shown.
- 5** A charge will be made in the event of an aborted service call by you but not by us, or where a call under the terms of guarantee has been booked and the failure is not product related (i.e. scaling and furring, incorrect water pressure, pressure relief device operation, electrical installation faults).
- 6** If the product is no longer covered by the guarantee, a charge will be made for the site visit and for any parts supplied.
- 7** Service charges are based on the account being settled when work is complete, the engineer will then request payment for the invoice. If this is not made to the service engineer or settled within ten working days, an administration charge will be added.

Replacement Parts Policy

Availability: It is the policy of Triton to maintain availability of parts for the current range of products for supply after the guarantee has expired. Stocks of spare parts will be maintained for the duration of the product's manufacture and for a period of five years thereafter. In the event of a spare part not being available a substitute part will be supplied.

Payment: The following payment methods can be used to obtain spare parts:

- 1** By post, pre-payment of pro forma invoice by cheque or money order.
- 2** By telephone, quoting credit card (MasterCard or Visa) details.
- 3** By website order, www.tritonshowers.co.uk

Triton Plc
Triton Road
Nuneaton
Warwickshire

CV11 4NR

TRITON STANDARD GUARANTEE

Triton Plc guarantee this product against all mechanical defects arising from faulty workmanship or materials for a period of five years for domestic use only, from the date of purchase, provided that it has been installed by a competent person in full accordance with the fitting instructions.

Any part found to be defective during this guarantee period we undertake to repair or replace at our option without charge so long as it has been properly maintained and operated in accordance with the operating instructions, and has not been subject to misuse or damage. This product must not be taken apart, modified or repaired except by a person authorised by Triton Plc. This guarantee applies only to products installed within the United Kingdom and does not apply to products used commercially. This guarantee does not affect your statutory rights.

What is not covered:

- 1** Breakdown due to: *a)* use other than domestic use by you or your resident family; *b)* wilful act or neglect; *c)* any malfunction resulting from the incorrect use or quality of water or incorrect setting of controls; *d)* faulty installation.
- 2** Repair costs for damage caused by foreign objects or substances.
- 3** Total loss of the product due to non-availability of parts.
- 4** Compensation for loss of use of the product or consequential loss of any kind.
- 5** Call out charges where no fault has been found with the appliance.
- 6** The cost of repair or replacement of pressure relief devices, shower heads, hoses, riser rails and/or wall bracket or any other accessories installed at the same time.
- 7** The cost of routine maintenance, adjustments, overhaul modifications or loss or damage arising therefrom, including the cost of repairing damage, breakdown, malfunction caused by corrosion, furring, pipe scaling, limescale, system debris or frost.

Customer Service: ☎ +44 (0) 24 7637 2222

Scottish and Northern Ireland

Customer Service: ☎ +44 (0) 84 5762 6591

Trade Installer Hotline: ☎ +44 (0) 24 7632 5491

Fax: +44 (0) 24 7632 4564

www.tritonshowers.co.uk

E mail: technical@triton.plc.uk