

## Aspirante Millennium



## Installation and Operating Instructions

**INSTALLERS PLEASE NOTE THESE INSTRUCTIONS ARE TO BE LEFT WITH THE USER**

<b>CONTENTS</b>	<b>Page</b>
Important safety information	1
Introduction	2
Understanding the Millennium	2
Key to main components	3
Electrical requirements	4 - 5
Water requirements	6
Siting of the shower	6 - 7
Fitting the shower to the wall	8
Plumbing connections	8 - 9
Electrical connections	10
Replacing the cover	11
Commissioning	12 - 13
Operating the shower	14 - 15
Operating functions	16
Adjusting the sprayhead	17
Cleaning	17
Spare parts	18
Cleaning the inlet filter	19
Temperature / flow rate graph	19
Fault finding	20
Guarantee, service policy, etc.	rear cover

To ensure the product suitability for commercial and multiple installations, please contact Triton's specification advisory service prior to installation.

Telephone: (024) 7632 5491

Facsimile: (024) 7632 4564

E mail: [technical@triton.plc.uk](mailto:technical@triton.plc.uk)

**PLEASE READ THIS IMPORTANT SAFETY INFORMATION**

- ◆ Products manufactured by Triton are safe and without risk provided they are installed, used and maintained in good working order in accordance with our instructions and recommendations.
- ◆ DO NOT operate shower if frozen, or suspected of being frozen. It must thaw out before using.
- ◆ DO NOT operate the unit if the sprayhead or spray hose becomes damaged.
- ◆ DO NOT restrict flow out of the shower by placing sprayhead in direct contact with your body.
- ◆ DO NOT operate the shower if water ceases to flow during use or if water has entered inside the unit because of an incorrectly fitted cover.

**1 GENERAL**

**1.1** Isolate the electrical and water supplies before removing the cover.

**1.2** Read all of these instructions and retain them for later use.

**1.3** DO NOT take risks with plumbing or electrical equipment.

**1.4** Isolate electrical and water supplies BEFORE proceeding with the installation.

**1.5** The unit must be mounted onto the finished wall surface (on top of the tiles). DO NOT tile up to unit after fixing to wall.

**1.6** Contact Customer Service (see back page), if any of the following occur;

- a)** If it is intended to operate the shower at pressures above the maximum or below the minimum stated.
- b)** If the unit shows a distinct change in performance.
- c)** If the shower is frozen.

**1.7** If it is intended to operate the shower in areas of hard water (above 200 ppm temporary hardness), a scale inhibitor may have to be fitted. For advice on the Triton Scale Inhibitor, contact Customer Service.

**1.8** The sprayplate and cartridge must be cleaned regularly with descalent to remove scale and debris, otherwise restrictions to the flow on the outlet of the unit will result in higher temperatures and could also cause the Pressure Relief Device in unit to operate.

**1.9** This product is not suitable for mounting into steam rooms or steam cubicles.

**2 PLUMBING**

**2.1** The plumbing installation must comply with Water Regulations, Building Regulations or any particular regulations as specified by Local Water Company or Water Undertakers and should be in accordance with BS 6700.

**2.2** The supply pipe must be flushed to clear debris before connecting to the shower unit.

**2.3** DO NOT solder pipes or fittings within 300mm of the shower appliance, as heat transfer can damage components.

**2.4** DO NOT fit any form of outlet flow control as the outlet acts as a vent for the heater can.

**2.5** DO NOT use excessive force when making connections to the flexible hose or sprayhead, finger tightness is sufficient.

**2.6** All plumbing connections MUST be completed BEFORE making the electrical connections.

**3 ELECTRICAL**

**3.1** The installation must comply with BS 7671 'Requirements for electrical installations' (IEE wiring regulations) or any particular regulations as specified by the local Electrical Supply Company.

**3.2** This appliance MUST be earthed.

**3.3** In accordance with 'The Plugs and Sockets etc. (Safety) Regulations 1994', this appliance is intended to be permanently connected to the fixed wiring of the electrical mains system.

**3.4** Ensure all electrical connections are tight to prevent overheating.

**3.5** Fuses do not give personal protection against electric shock.

**3.6** *To enhance electrical safety* a 30mA residual current device (RCD) should be installed in all UK electric and pumped shower circuits. This may be part of the consumer unit or a separate unit.

**3.7** Switch off immediately at isolating switch if water ceases to flow during use.

**3.8** Other electrical equipment i.e. extractor fans, pumps must not be connected to the circuits within the unit.

**3.9** Switch off at isolating switch when not in use. This is a safety procedure recommended with all electrical appliances.

**3.10** As with all electrical appliances it is recommended to have the shower and installation checked at least every two years by a competent electrician to ensure there is no deterioration due to age and usage.

## INTRODUCTION

This book contains all the necessary fitting and operating instructions for your Aspirante Millennium electric shower. Take time to read this book thoroughly and familiarise yourself with all instructions *before* commencing installation. Please keep it for future reference.

*The shower installation must be carried out by a suitably qualified person and in the sequence of this instruction book.*

Care taken during the installation will ensure a long, trouble-free life from your shower.

## SPECIFICATIONS

### Electrical

Nominal power rating at 240V	Nominal power rating at 230V
8.5kW – (40A MCB rating)	7.8kW – (40A MCB rating)
9.5kW – (40A MCB rating)	8.7kW – (40A MCB rating)

### Water

Inlet connection – 15mm diameter.

Outlet connection – 1/2" BSP male thread.

### Entry Points

Water – top, bottom, back or right.

Cable – top, bottom, back or right.

### Materials

Backplate, cover, controls, sprayhead – ABS.

Sprayplate – Acetal.

Elements – Minerally insulated corrosion resistant metal sheathing.

### Dimensions (in millimetres)

Height - 413, Width - 243, Depth - 97

### Standards and Approvals

Splashproof rating IPX4.

Complies with the requirements of current British and European safety standards for household and similar electrical appliances.

Complies with requirements of the British Electrotechnical Approvals Board (BEAB).

Meets with Compliance with European Community Directives (CE).

Due to continuous improvement and updating, specification may be altered without prior notice.

## UNDERSTANDING YOUR MILLENNIUM

### a) Temperature /flow rate

The temperature control on the unit can be adjusted to provide shower temperatures between 35°C and 47°C.

Alternatively, the shower temperature can be restricted by moving the set-up link on the cover PCB to one of three positions, providing 41°C, 43°C or 47°C maximum.

At a selected temperature the unit will maintain a set flow rate.

The unit has 4 flow options:

- 1 Cold (4.5 litres per minute)
- 2 Low flow (3 litres per minute)
- 3 Medium flow (4.5 litres per minute)
- 4 High flow (maximum obtainable 6 litres per minute – average)

If the unit is unable to maintain a stated flow rate for the temperature required due to variations in incoming water temperature/pressure, the unit will supply the maximum flow rate possible.

Note the maximum flow rate for the given temperature will be greater in the Summer than in the Winter because of the variance in the ambient mains water supply.

### b) Temperature stabilisation

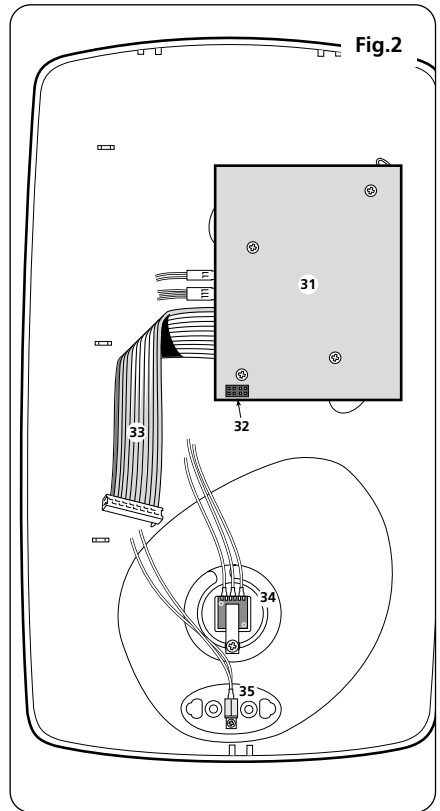
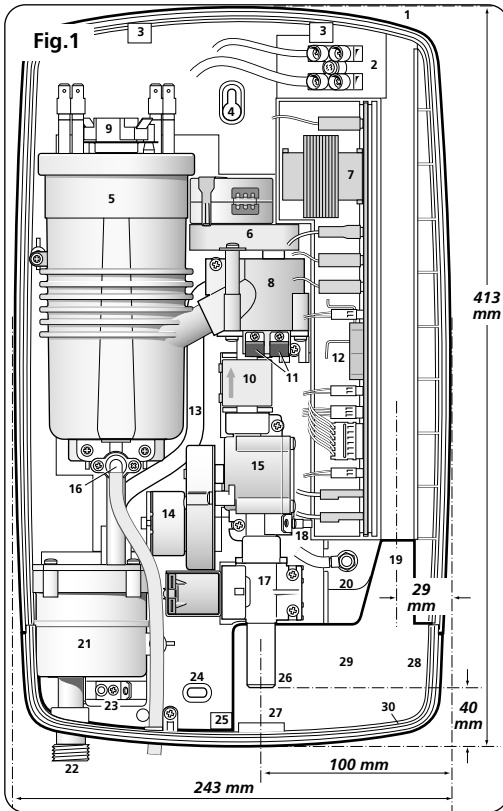
The shower will maintain the user's selected temperature to within +1°C when pressure changes occur (within the pressure range stated in the site requirements) and when there are fluctuations in voltage (within the UK supply tolerance) and inlet water temperature.

### c) Safety cut-out

The unit is fitted with a non resettable over-temperature safety device. In the event of abnormal operation which could cause unsafe temperatures within the unit, the device will disconnect the heating elements. It will require a visit from a qualified engineer to determine the nature of the fault and replace the safety device, once the unit has been repaired.

**Important:** When first installed the heater can will be empty. It is essential the can should contain water *before* the elements are switched on. As this unit has electronic control, it is *vital* that the commissioning procedure is followed as instructed. Failure to carry out this operation will result in damage to the unit and will invalidate the guarantee.

KEY TO MILLENNIUM COMPONENTS



**Inside unit (fig.1)**

- |                                |                                       |
|--------------------------------|---------------------------------------|
| 1 Top cable or pipe entry      | 14 DC motor                           |
| 2 Terminal block               | 15 Flow control valve                 |
| 3 Cover screw fixing – top     | 16 Pressure Relief Device (PRD)       |
| 4 Wall fixing hole – top       | 17 Solenoid valve                     |
| 5 Can & element assembly       | 18 Inlet sensor                       |
| 6 Stepper motor                | 19 Cable and pipe exit from top entry |
| 7 Transformer on PCB           | 20 Earth post                         |
| 8 Splitter valve               | 21 Mixing chamber                     |
| 9 Thermal safety cut-out       | 22 Shower outlet                      |
| 10 Flow meter                  | 23 Outlet sensor                      |
| 11 Triac switches              | 24 Wall fixing hole – bottom          |
| 12 Connector for cover ribbon  | 25 Cover screw fixing – bottom        |
| 13 Cold feed to mixing chamber | 26 Shower inlet                       |
|                                | 27 Bottom cable or pipe entry         |

- |                                       |
|---------------------------------------|
| 28 Side entry for cable or pipe       |
| 29 Back entry area for pipe and cable |
| 30 Trimplate                          |

**Inside cover (fig.2)**

- |  |
|--|
| 31 Control PCB                                   |
| 32 Set-up link (factory set at 'purge' position) |
| 33 Ribbon - 20 way                               |
| 34 Potentiometer                                 |
| 35 Start/stop switch                             |

**Riser rail kit boxed separately**

**ELECTRICAL REQUIREMENTS**

**WARNING**  
THIS APPLIANCE MUST BE EARTHED

The installation, supply cable and circuit protection must conform with IEE wiring regulations and be sufficient for the amperage required.

The following notes are for guidance only:

**1** The shower must only be connected to a 230-240V ac supply. If you are installing a shower with a kilowatt rating above 9kW, it is advisable to contact the local electricity supply company.

**1.1** The electrical rating of the shower is shown on the rating label (fig.3) within the unit.



Fig.3

**2** Before making any sort of electrical connection within the installation, ensure that no terminal is live. If in any doubt, switch off the whole installation at the consumer unit.

**3** The shower must be connected to its own independent electrical circuit. IT MUST NOT be connected to a ring main, spur, socket outlet, lighting circuit or cooker circuit.

**3.1** The electrical supply must be adequate for the loading of the unit and existing circuits.

**4** Check your consumer unit (main fuse box) has a main switch rating of 80A or above and that it has a spare fuse way which will take the fuse or mcb necessary for the shower (fig.4).

**4.1** If your consumer unit has a rating below 80A or if there is no spare fuse way, then the installation will not be straight forward and may require a new consumer unit serving the house or just the shower.

**4.2** You will need to contact the local electricity company. They will check the circuit and carry out what is necessary. They will also check the main bonding.

**5** The earth continuity conductor of the electrical installation must be effectively connected electrically to all exposed metal parts of other appliances and services in the room in which the shower is to be installed, to conform to current IEE regulations.

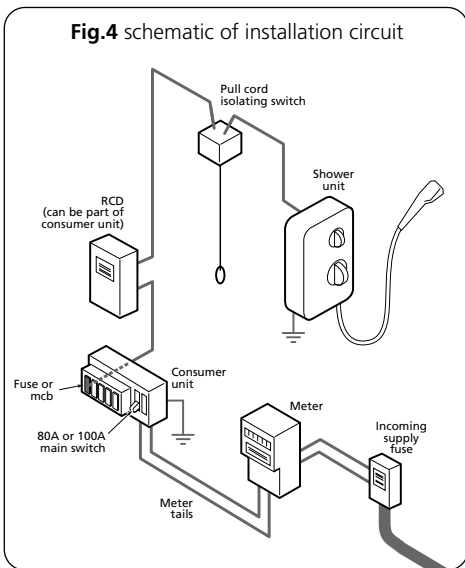


Table A

CIRCUIT PROTECTION		
unit rating	mcb	cartridge fuse
7.0kW	30/32A	30A
7.5kW	32A	35A
8.0kW	40A	35A
8.5kW	40A	45A
9.0kW	40A	45A
9.5kW	40/45A	45A
10.5kW	45A	45A

## ELECTRICAL REQUIREMENTS

**5.1** All exposed metallic parts in the bathroom must be bonded together using a cable of at least 4mm<sup>2</sup> cross sectional area. These parts include metal baths, radiators, water pipes, taps and waste fittings.

**6** For close circuit protection DO NOT use a rewirable fuse. Instead use a suitably rated miniature circuit breaker (MCB) or cartridge fuse (see table A).

**6.1** In the interest of electrical safety a 30mA residual current device (RCD) should be installed in all UK electric and pumped shower circuits. This may be part of the consumer unit or a separate unit.

**7** A 45 amp double pole isolating switch with a minimum contact gap of 3mm in both poles must be incorporated in the circuit.

**7.1** It must have a mechanical indicator showing when the switch is in the OFF position, and the wiring must be connected to the switch without the use of a plug or socket outlet.

**7.2** The switch must be accessible and clearly identifiable, but out of reach of a person using a fixed bath or shower, except for the cord of a cord operated switch, and should be placed so that it is not possible to touch the switch body

while standing in a bath or shower cubicle. It should be readily accessible to switch off after using the shower.

**8** Where shower cubicles are located in any rooms other than bathrooms, all socket outlets in those rooms must be protected by a 30mA RCD.

**9** The current carrying capacity of the cable must be at least that of the shower circuit protection (see table B).

**9.1** To obtain full advantage of the power provided by the shower, use the shortest cable route possible from the consumer unit to the shower.

**9.2** It is also necessary to satisfy the disconnection time and thermal constraints which mean that for any given combination of current demand, voltage drop and cable size, there is a maximum permissible circuit length.

**10** The shower circuit should be separated from other circuits by at least twice the diameter of the cable or conduit.

**10.1** The current rating will be reduced if the cabling is bunched with others, surrounded by thermal loft or wall insulation or placed in areas where the ambient temperature is above 30°C. Under these conditions, derating factors apply and it is necessary to select a larger cable size.

**10.2** In the majority of installations, the cable will unavoidably be placed in one or more of the above conditions. This being so, it is strongly recommended to use a minimum of 10mm cabling throughout the shower installation.

**10.3** In any event, it is essential that individual site conditions are assessed by a competent electrician in order to determine correct cable size and permissible circuit length.

Table B

**Twin and earth PVC insulated cable  
CURRENT CARRYING CAPACITY**

installed in an insulated wall	in conduit or trunking	clipped direct or buried in a non insulated wall
6mm <sup>2</sup>	6mm <sup>2</sup>	6mm <sup>2</sup>
32A	38A	46A
10mm <sup>2</sup>	10mm <sup>2</sup>	10mm <sup>2</sup>
43A	52A	63A
16mm <sup>2</sup>	16mm <sup>2</sup>	16mm <sup>2</sup>
57A	69A	85A

**Note: Cable selection is dependent on derating factors**

**WATER REQUIREMENTS**

The installation must be in accordance with Water Regulations/Byelaws.

To ensure activation of the heating elements, the shower must be connected to a mains water supply with a minimum running pressure of 100kPa (1.0 bar) at a minimum flow rate of eight litres per minute for the 8.5kW rated model and nine litres per minute for the 9.5kW rated model. For all units the maximum static pressure must be 1000kPa (10 bar).

If in any doubt, the pressure should be checked.

NOTE: If the stated flow rate are not available, it may not be possible to achieve optimum performance from the unit throughout the year.

The water supply can be taken from a cold water storage cistern provided there is a minimum head of ten metres. Minimum head is the vertical distance from the base of the cistern to the sprayhead. It must be an independent supply to the shower only.

If it is intended to operate the shower at pressures above the maximum or below the minimum stated, contact Customer Service for advice.

**Fig.5** shows a typical system layout.

*Do not* use jointing compounds on any pipe fittings for the installation.

**SITING OF THE SHOWER**

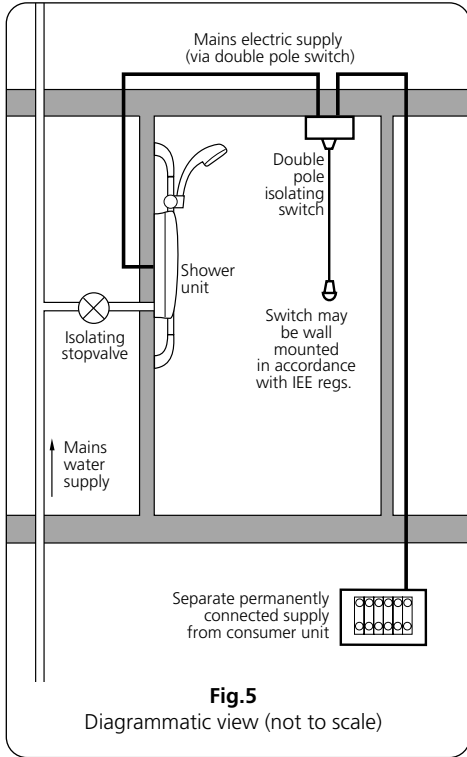
**WARNING: The shower must not be positioned where it will be subjected to freezing conditions.**

FOR EASE OF SERVICING, THE UNIT MUST ALWAYS BE MOUNTED ON THE SURFACE OF TILED WALLS. NEVER TILE UP TO THE UNIT.

Refer to **fig.6** for correct siting of shower. Position the unit where it will NOT be in direct contact with water from the sprayhead. Position the shower unit vertically.

Allow sufficient room between the ceiling and the shower to access the cover top screws.

NOTE: Water Regulations (shower hose connections) requires the sprayhead be 'constrained by a fixed or sliding attachment so that it can only discharge water at a point not less than 25mm above the spill-over level of the relevant bath, shower tray or other fixed



**Fig.5**

Diagrammatic view (not to scale)



appliance'. The use of the supplied soap dish will in most cases meet this requirement, but if the sprayhead can be placed within a bath, basin or shower tray, then a double check valve, or similar, must be fitted in the supply pipework to prevent back-flow.

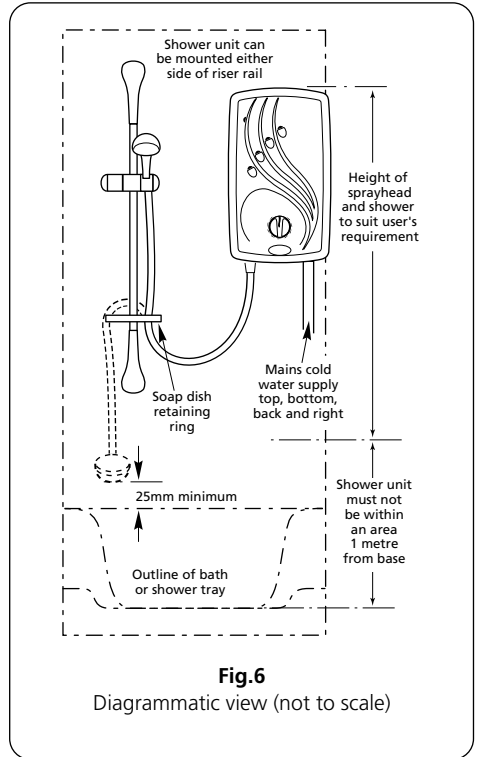
**Pressure relief safety device**

A pressure relief device (PRD) is designed into the shower unit which complies with European standards. The PRD provides a level of appliance protection should an excessive build up of pressure occur within the shower.

DO NOT operate the shower with a damaged or kinked shower hose, or a blocked sprayhead which can cause the PRD to operate.

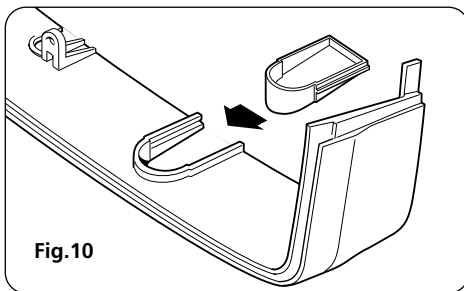
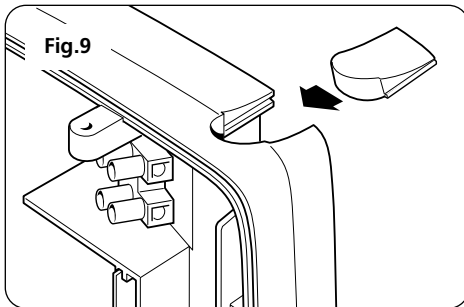
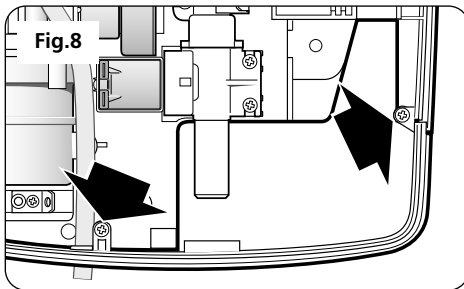
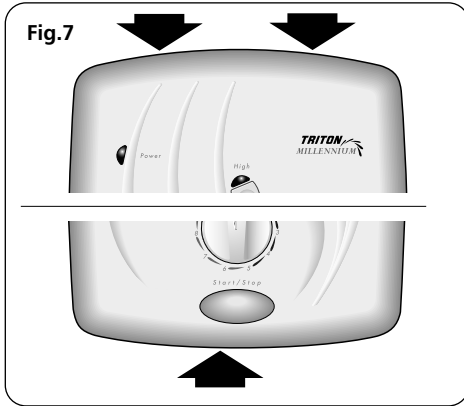
When commissioning, the sprayhead must be removed from the flexible hose, while at the same time the temperature control must be at the minimum flow position. Failure to follow this procedure may also cause the PRD to operate.

Ensure the shower is positioned over a bath or shower tray because if the PRD operates, then water will eject from the bottom of the unit. Should this happen, turn off the electricity and water supplies to the shower at the isolating switch and stopvalve. Contact Customer Service for advice on replacing the PRD.



**Fig.6**  
Diagrammatic view (not to scale)

**Important:** The unit must be mounted on a flat surface which covers the full width and length of the backplate. It is important that the wall surface is flat otherwise difficulty may be encountered when fitting the cover and subsequent operation of the unit may be impaired.



### FITTING THE SHOWER TO WALL

NOTE: The control knob is an integral part of the cover – do not attempt to remove it.

Unscrew the two top and one bottom retaining screws (**fig.7**) and lift the cover from the backplate. To facilitate the pipe and cable connections, remove the two screws (**fig.8**) and take off the trimplate.

Entry positions for the mains water and cable supplies are from the top, bottom, back or from the right hand side.

NOTE: Deviations from the designated entry points will invalidate product approvals.

If bottom entry is chosen for the mains water and cable, fit the appropriate trim in the top of the backplate (**fig.9**).

If top entry is chosen for the mains water and cable, fit the appropriate trim in the bottom of the trimplate (**fig.10**).

If side entry is required, the trimplate will have to be cut out. Carefully remove the appropriate area by using a knife or junior hacksaw (**fig.11**).

If installing a feed pipe from the rear or bottom, the centre of the inlet valve to the wall surface is 21.5mm (**fig.12**).

NOTE: If entry is from the rear, the nut of the compression fitting will be partially behind the surface of the wall (**fig.12**). This area **MUST** be left clear when plastering over the pipework in order to make the nut accessible for future adjustments.

After choosing the site for the shower, use the backplate as a template and mark the two fixing holes (**fig.13**). Drill and plug to suit the fixing screws supplied. *(The wallplugs provided are suitable for most brick walls – use an appropriate masonry drill, but if the wall is plasterboard or a soft building block, you must use special wallplugs and an appropriate drill obtainable from most hardware stores).*

Screw the top fixing screw into position leaving the base of the screw head protruding 6mm (0.25in) out from the wall.

Hook the backplate over the top screw and fit the bottom fixing screw into position.

Do not fully tighten the screws at this stage, as the fixing holes are elongated to allow for out of square adjustment after the plumbing connections have been completed.

**PLUMBING CONNECTIONS**

***Plumbing to precede wiring.***

**WARNING:** The outlet of the shower acts as a vent and must not be connected to anything other than the hose and sprayhead supplied.

DO NOT use jointing compounds on any pipe fittings for the installation.

DO NOT use soldered fittings within the vicinity of the shower unit.

Compression fittings MUST be used to connect to the inlet of the shower. (Push-on fittings must NOT be used as full engagement cannot be guaranteed).

NOTE: An additional stopvalve (complying with Water Regulations) MUST be fitted in the mains water supply to the shower as an independent means of isolating the water supply should maintenance or servicing be necessary.

**Important:** Before completing the connection of the water supply to the inlet of the shower, flush out the pipework to remove all swarf and system debris. This can be achieved by connecting a hose to the pipework and turning on the mains water supply long enough to clear the debris to waste.

**Procedure:** Turn off the water supply either at the mains stopvalve or the isolating stopvalve.

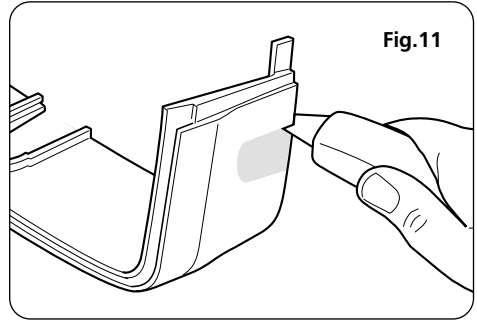
Connect the mains water supply to the inlet of the shower via 15mm copper, stainless steel pipe or plastic pipe using a 15mm x 15mm elbow or straight compression fitting.

DO NOT use excessive force when making these connections.

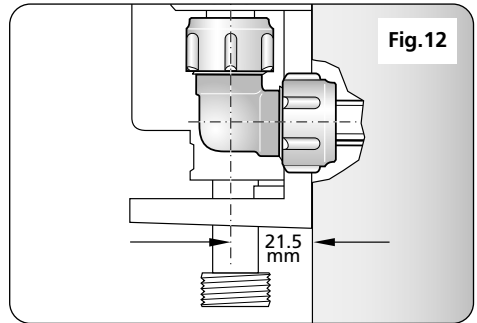
Ensure the backplate is square on the wall and tighten the two retaining screws which hold it to the wall.

Turn on the mains water supply and check for leaks in the pipework connection to the shower.

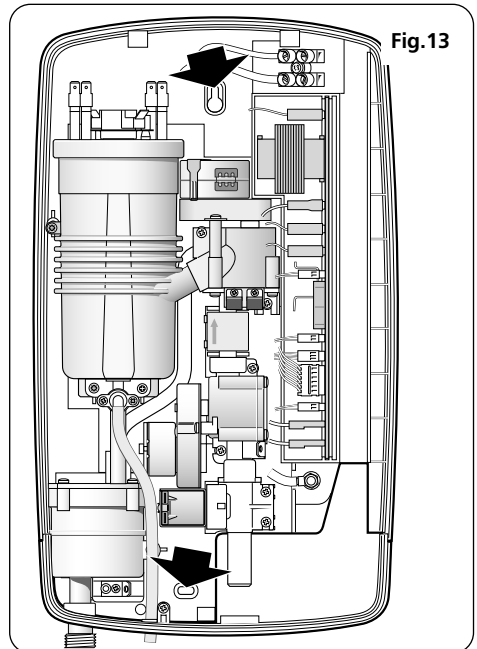
NOTE: At this stage no water can flow through the unit.



**Fig.11**

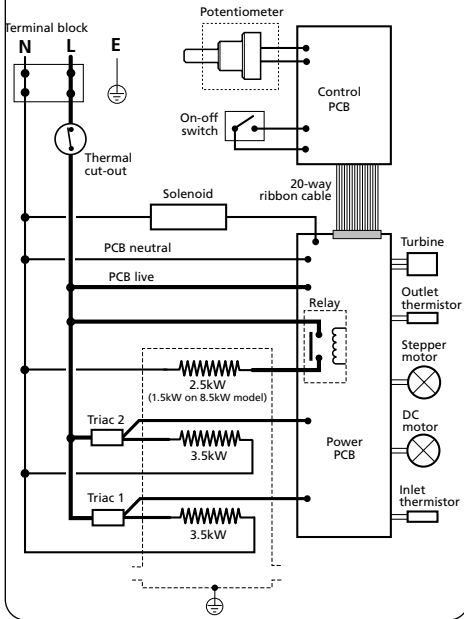


**Fig.12**



**Fig.13**

Fig.14




**ELECTRICAL CONNECTIONS**

SWITCH OFF THE ELECTRICITY SUPPLY.

**Fig.14** shows a schematic wiring diagram.

The cable entry points are shown in **fig.1**. The cable can be surface clipped, hidden or via 20mm conduit.

NOTE: Conduit entry can only be from rear. Route the cable into the shower unit and connect to the terminal block (**fig.15**) as follows:

*Earth cable to terminal marked E* 

*Neutral cable to terminal marked N*

*Live cable to terminal marked L*

**IMPORTANT: Fully tighten the terminal block screws and ensure that no cable insulation is trapped under the screws. Loose connections can result in cable overheating.**

NOTE: The supply cable earth conductor must be sleeved. The outer sheath of the supply cable must be stripped back to just before the terminal block.

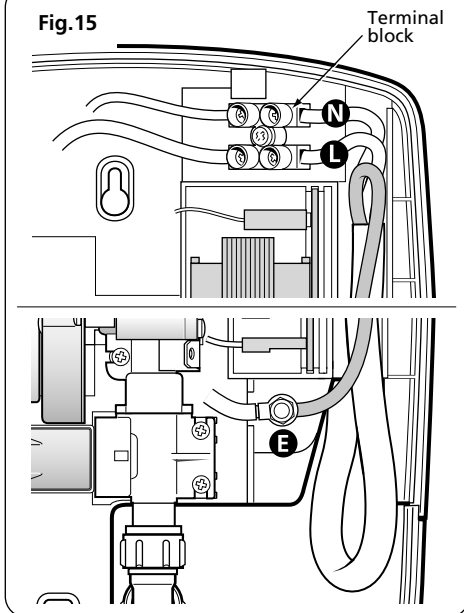
The supply cable must be secured either by routing through conduit or in trunking or by embedding in the wall, in accordance with current IEE regulations.

The earth continuity conductor of the electrical installation must be effectively connected electrically to all exposed metal parts of other appliances and services in the room in which the shower is to be installed, to conform to current IEE regulations.

**WARNING:** The use of connections within the unit to supply power to other equipment i.e. extractor fans, pumps etc. will invalidate the guarantee.

**DO NOT switch on the electricity supply until the cover has been fitted.**

Fig.15



NOTE: The elements on UK models are to 240V specification and will give a lower kW rating if the voltage supply is below 240V.

### REPLACING THE COVER

Refit the trimplate and secure with the two retaining screws (**fig.16**).

**Important:** Before finally fitting the cover, the following checks must be observed:

- a) Check plumbing connections for leaks.
- b) Check terminal block screws are fully tightened.
- c) Check that pipe and cable entering the unit do not prevent the cover locating correctly to the backplate.
- d) Ensure the set-up link is located on the left hand set of pins - 'purge' position (**fig.17**) on the control PCB inside the cover.
- e) Ensure the potentiometer cover (**fig.18**) is in place.

Offer the cover to the unit. Attached to the control PCB, inside the cover, is a 20-way ribbon cable. The ribbon cable connector must be plugged into the socket located at the centre of the PCB on the right hand side of the unit (**fig.19**).

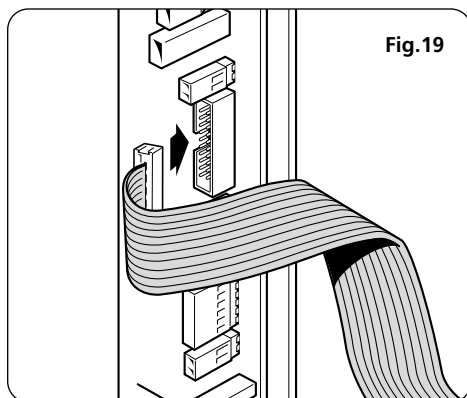
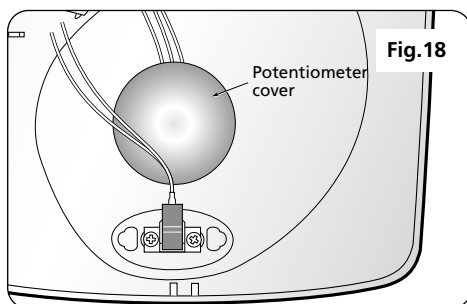
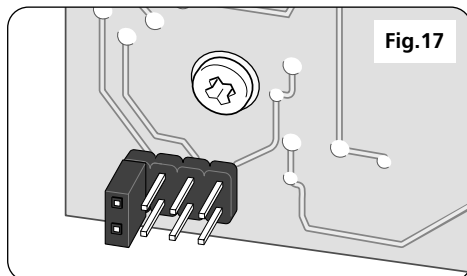
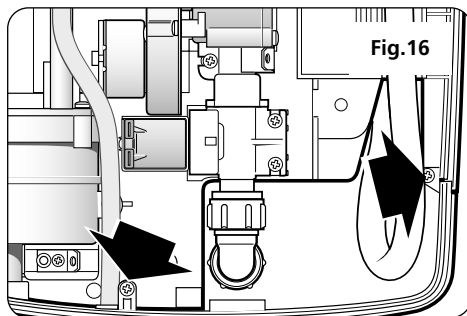
NOTE: The ribbon cable is preformed to fold flat when the cover is fitted.

Carefully replace the cover squarely to the backplate and ensure that wires are not trapped. Should any difficulty arise, recheck the points above.

Whilst applying slight pressure to the front cover, secure in position with the three retaining screws.

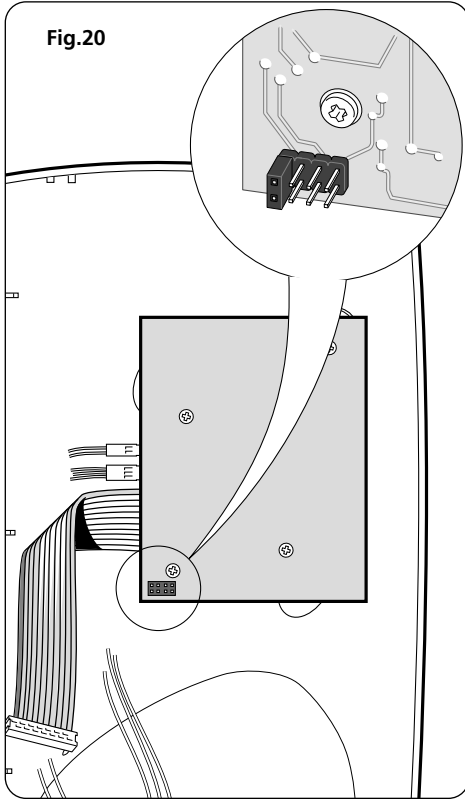
**DO NOT switch on the electricity supply to the shower until the commissioning procedure has been carried out.**

*Before proceeding with the commissioning it is advisable at this point to fit the riser rail kit and shower hose. Please refer to the fitting instructions supplied with the riser rail kit.*



## COMMISSIONING

Fig.20



**WARNING:** BEFORE NORMAL OPERATION OF THE SHOWER, IT IS ESSENTIAL THAT THE COMMISSIONING AND SETUP PROCEDURE ARE CORRECTLY COMPLETED.

AT THIS STAGE THE START/STOP BUTTON MUST **NOT** BE PRESSED.

IT MAY DAMAGE THE SHOWER UNIT AND WILL INVALIDATE THE GUARANTEE.

The first operation of the shower is intended to flush out any remaining system debris and to ensure water is purged through the unit. This operation must be carried out with the flexible hose screwed to the shower outlet but *without* the sprayhead attached.

Ensure the outlet of the flexible hose is directed to waste.

*Before* turning on the electric supply to the shower, ensure that the cover is fitted.

Ensure the water supply to the shower is turned on at the isolating stopvalve.

Switch on the electricity supply to the shower at the isolating switch. Immediately the flow control button indicators will light up in sequence and repeatedly flash while water starts to flow from the flexible hose.

It will take approximately sixty seconds for a smooth flow of water to be obtained whilst air and any debris is being dispersed from the shower.

*Once the flushing out has been completed, DO NOT PRESS THE START/STOP BUTTON but stop the water flow only by switching off the electricity supply to the shower at the isolating switch.*

**Setup link procedure**

Unscrew the top and bottom retaining screws (**fig.6**) again and remove the cover from the backplate. It is not necessary to disconnect the twenty way ribbon cable as long as it is convenient to support the cover with one hand while moving the setup link with the other.

*Do not let the cover dangle with the weight taken by the cable.*

The setup link is located on the bottom left corner of the control PCB inside the cover (**fig.20**)

Apart from the 'purge' position, there are three other sets of pins on which the link can be placed as indicated (**fig.21**). These represent the maximum temperature restrictions (41°C, 43°C, or 47°C) of the shower when the temperature control is turned fully clockwise to '10'.

For normal use, place the link on the right hand set of pins (47°C maximum – **fig.22**).

For situations where the main usage of the shower is for the elderly or young children, then place the link on either of the other two sets of pins (41°C or 43°C). This will restrict the maximum temperature to these limits should the temperature control otherwise be accidentally turned up too high.

### Replacing the cover

Carefully locate the cover into the backplate, ensuring wires are not trapped, and guide into position.

Whilst applying slight pressure to the front cover, secure in position with the three retaining screws.

Turn the electric supply back on at the isolating switch.

Fit the sprayhead to the flexible hose and place in sprayhead holder.

The shower is now ready for normal operation.

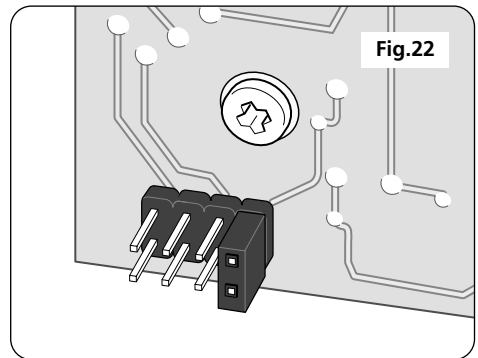
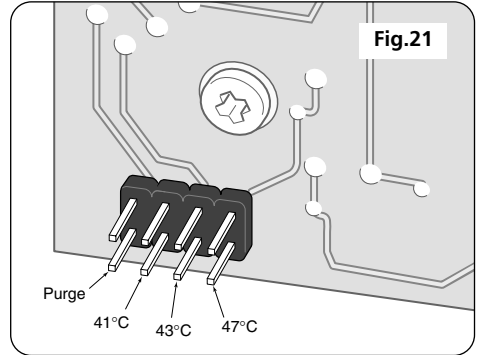
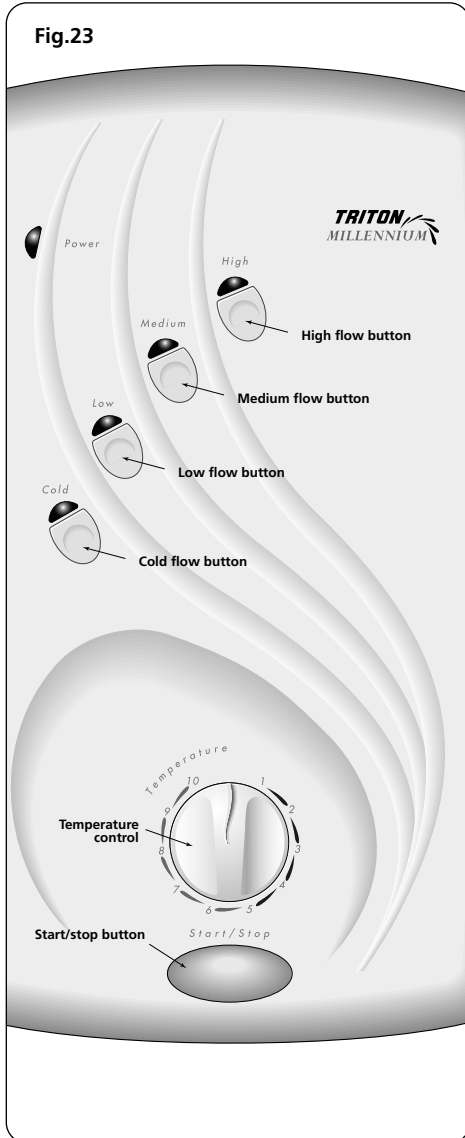


Fig.23



## OPERATING THE SHOWER

Ensure the commissioning procedure has been carried out.

NOTE: Whenever power is switched on at the isolating switch, the shower will run through a start-up routine and the LED indicators will light up in sequence for a few seconds.

### To start the shower

The shower can be started in two ways. Either by pressing the start/stop button (**fig.23**) or by pressing any of the four flow buttons.

Pressing the start/stop button will start water to flow at the high flow rate by default. The high flow indicator will light.

Pressing any one of the four flow buttons will start water to flow. The appropriate indicator will light. (See below for detailed operation).

### To stop the shower

Press the start/stop button and the phased shutdown will commence. Water will cease to flow after approximately four seconds.

For correct operation, the unit should always be switched off at the start/stop button, prior to switching off at the isolating switch.

### To use the flow control buttons

There are four control buttons (cold, low, medium and high) as shown in **fig.23**.

These control and maintain the flow only, at any selected temperature.

**Cold** is for cold water only. Adjustment of the temperature control at this setting will have no effect on the flow of water. Cold water at the ambient temperature will flow at a maximum of 4.5 litres per minute.

**Low** maintains a maximum flow rate of 3 litres per minute regardless of the temperature control position. The shower automatically adjusts to maintain the flow rate at the selected temperature and not to increase more than + 1°C of the setting.

**Medium** maintains a maximum flow rate of 4.5 litres per minute regardless of the temperature control position. The shower automatically adjusts to maintain the flow rate at the selected temperature and not to increase more than + 1°C of the setting.



**High** allows the maximum flow possible for your selected temperature. The shower automatically adjusts to provide the highest flow rate achievable at the selected temperature and not to increase more than + 1°C of the setting. This setting should be regarded as normal for optimum shower performance throughout the year.

NOTE: If the unit is unable to maintain a selected flow rate for the temperature required due to variations in incoming water temperature/pressure, the unit will supply the maximum flow rate possible.

### **Adjusting the shower temperature**

The water temperature is altered by adjusting the temperature control (**fig.23**).

For a cooler shower temperature, turn the temperature control anti-clockwise towards the lower numbers.

For a hotter shower, turn the temperature control clockwise towards the higher numbers.

After obtaining your preferred showering temperature, the number can be remembered and left as the normal setting.

NOTE: It is advisable to be certain that the showering temperature is satisfactory by testing with your hand *before* stepping under the sprayhead.

There will always be a time delay of a few seconds between selecting a temperature and the water reaching the stable temperature.

**Caution:** It is recommended that persons who may have difficulty understanding or operating the shower controls should not be left unattended whilst showering.

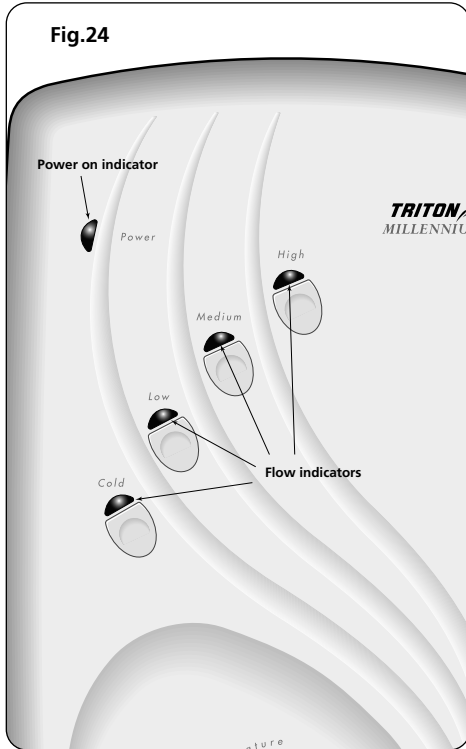
Special consideration should be given to young children and the less able bodied.

NOTE: IN NORMAL USE, IT IS IN ORDER TO LEAVE THE WATER SUPPLY PERMANENTLY ON TO THE SHOWER UNIT, BUT AS WITH MOST ELECTRICAL APPLIANCES, **THE UNIT MUST BE SWITCHED OFF AT THE ISOLATING SWITCH WHEN NOT IN USE.**

### **WARNING**

*After any servicing of mains water supply, always ensure the unit is started on COLD in order to purge any air in the pipework.*

Fig.24



## OPERATING FUNCTIONS

### Power on indicator (fig.24)

When the electricity supply to the shower is switched on at the isolating switch, the 'power' indicator will light, and will remain lit until the power is switched off again at the isolating switch.

NOTE: Whenever power is switched on at the isolating switch, the shower will run through a start-up routine and the LED indicators will light up in sequence for a few seconds.

### Flow indicators (fig.24)

Above each flow button there is an LED which indicates the flow option in use.

### Phased shutdown

In use, when the start/stop button is pressed, power is switched off to the elements. Water continues to flow for a few seconds, flushing out any remaining hot water. This ensures the next immediate user will not receive a slug of hot water if standing under the sprayhead when starting the shower.

### Low flow sensor

Should the mains water pressure fall below the minimum specified operating pressure, the low flow LED will flash continuously and the unit will turn off. When pressure returns to normal the shower can be restarted by pressing the start or flow buttons. If the unit fails to return to normal operation it will be necessary to have the water supply and unit checked.

### Safety cut-out

The unit is fitted with a non resettable over-temperature safety device. In the event of abnormal operation which could cause unsafe temperatures within the unit, the device will disconnect the heating elements. It will require a visit from a qualified engineer to determine the nature of the fault and replace the safety device, once the unit has been repaired.

### ADJUSTING THE SPRAYHEAD

Four sprayhead patterns are available (fig.25). Adjustment is by turning the bezel on the sprayhead in either direction until the desired pattern is obtained.

*MAXI*: A full spray perfect for a relaxing shower.

*ULTRA*: A focused spray for a refreshing, satisfying shower.

*NEEDLE*: A tingling, fine spray for a highly invigorating shower.

### CLEANING

**Do not use abrasive or solvent cleaning fluids. The shower unit, riser rail, hose, etc. should be cleaned using a soft cloth and warm water.**

It is advised before cleaning, to turn the isolation switch off, thus avoiding the shower being accidentally switched on.

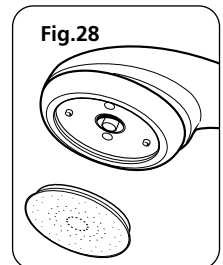
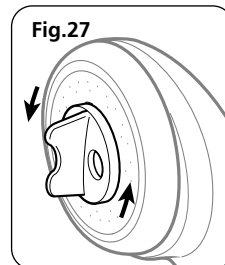
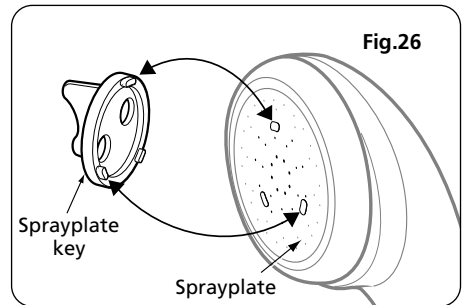
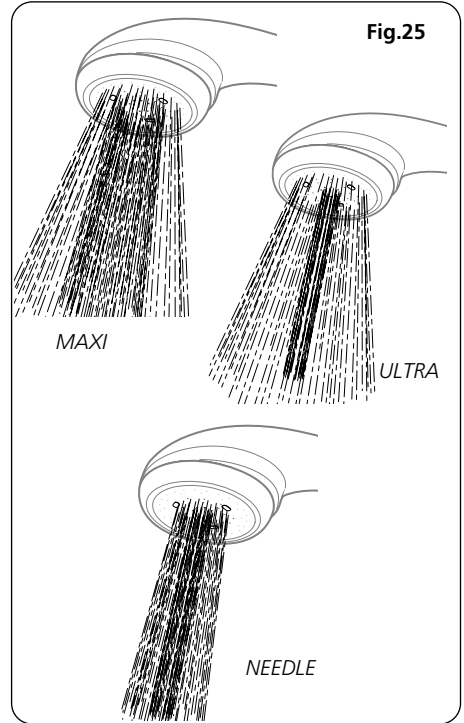
IT IS IMPORTANT TO KEEP THE SPRAYHEAD CLEAN TO MAINTAIN THE PERFORMANCE OF THE SHOWER. The hardness of the water will determine the frequency of cleaning. For example, if the shower is used every day in a very hard water area, it may be necessary to clean the sprayhead on a weekly basis.

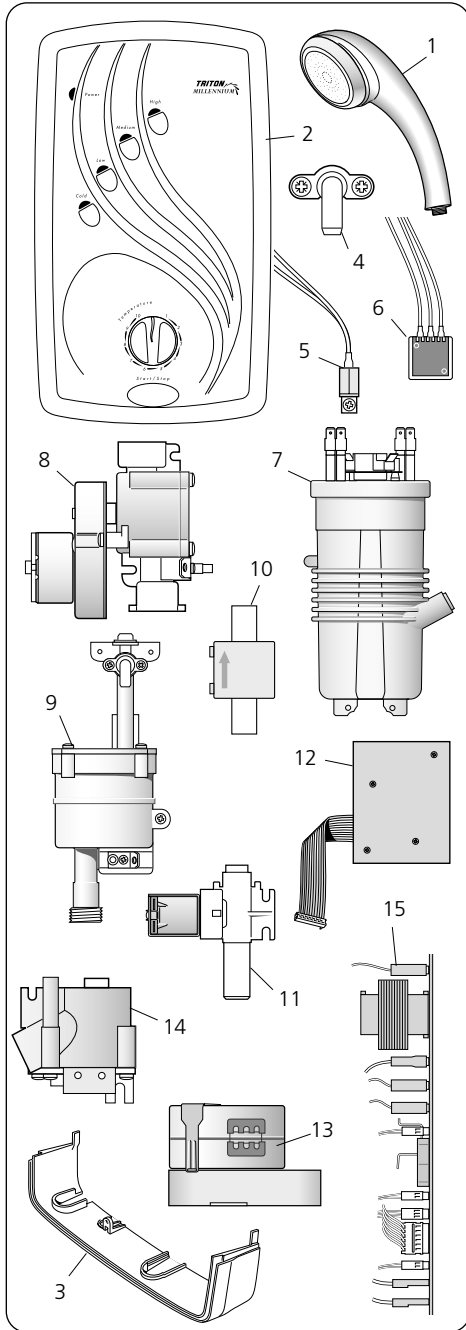
### Sprayplate removal

There is no need to remove the sprayhead from the hose. Using the removal tool supplied (fig.26), locate the three raised 'bosses' into the three recesses in the sprayplate. Hold in firmly and twist anti-clockwise (fig.27). This movement may turn the cartridge assembly as well until it reaches a 'stop'. Hold the cartridge firmly and continue to twist anti-clockwise. Having loosened the sprayplate sufficiently, it can be unscrewed and removed completely (fig.28).

Clean the sprayplate with a suitable brush or preferably leave to soak overnight in a mild proprietary descaler. Ensure all traces of scale are removed and thoroughly rinse in clean water afterwards.

Before replacing the sprayplate, switch the power back on at the isolating switch, direct the hose and sprayhead to waste and press the 'COLD' button. This operation will flush out any loose scale deposits in the unit and sprayhead. Stop after approximately thirty seconds. Refit the sprayplate by screwing clockwise. Use the tool to screw the sprayplate tight.





Ref	Description	Part No.
1	3 mode sprayhead white/chrome all white white/gold	22420020
		22420040
		22440070
2	Cover assembly	83305610
3	Trimplate	7052227
4	Pressure Relief Device	82800450
5	Start/stop switch	83305770
6	Potentiometer	82300610
7	Heater can assembly 8.5kW 9.5kW	83306500
		83306510
8	Flow control valve and motor assembly	82600580
9	Mixing chamber assembly	83305640
10	Flow meter assembly	83305650
11	Solenoid valve assembly	83305780
12	Cover PCB 8.5kW 9.5kW	83306500
		83306510
13	Stepper motor	22008460
14	Splitter valve assembly	83305670
15	Power PCB	7072240
-	Terminal block & wires	82200520
-	Wire kit	83306520
-	Inlet sensor	22008190
-	Outlet sensor	22008200
-	Triac switch assembly	82300580
-	Potentiometer cover	22010180
-	Extension lever	83305760

**INSTRUCTIONS FOR INSTALLERS AND SERVICE ENGINEERS ONLY**

**CLEANING THE INLET FILTER**

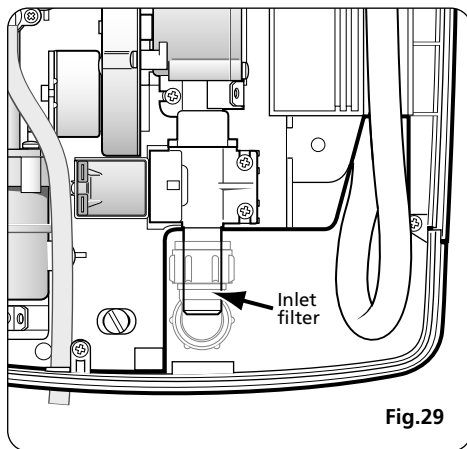
It is recommended that the filter is periodically cleaned in order to maintain the performance of the shower. *It is essential that this operation is carried out by a competent person.*

SWITCH OFF THE ELECTRICITY SUPPLY.

The inlet filter is situated in the inlet pipe which is part of the solenoid valve (**fig.29**).

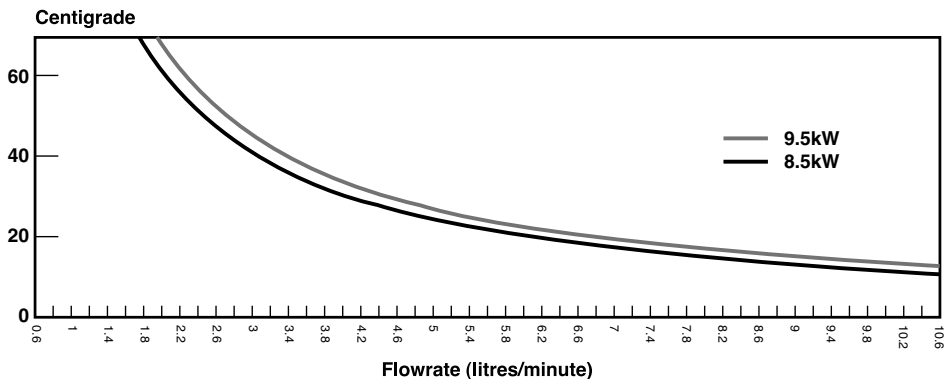
To gain access to the filter will require the trimplate to be removed and disconnecting and removal of the compression fitting. Also, depending on the incoming pipework arrangements, if there is not enough slack in the pipework, it could mean the removal of the unit from the wall.

When cleaning the wire mesh filter, *do not* use a sharp object, as it will cause damage. It is preferable to use an old toothbrush or similar.



**Fig.29**

**Temperature / flow rate graph (0° C ambient)**



**FAULT FINDING**

**IMPORTANT: Switch OFF the electricity at the mains supply and remove the circuit fuse before removing the cover from the shower while attempting any fault finding inside the unit.**

<b>Problem/Symptom</b>	<b>Cause</b>	<b>Action/cure</b>
<b>1</b> Shower inoperable	<b>1.1</b> Interrupted power supply.	<b>1.1.1</b> Blown fuse or circuit breaker. Check supply. Renew or reset fuse or circuit breaker. If it fails again, consult a qualified electrician.
	<b>1.2</b> Unit malfunction.	<b>1.2.1</b> Contact Customer Service for advice.
<b>2</b> Water too hot.	<b>2.1</b> Temperature control incorrect setting.	<b>2.1.1</b> Turn anti-clockwise.
	<b>2.2</b> Unit malfunction.	<b>2.2.1</b> Contact Customer Service for advice.
<b>3</b> Water too cool or cold.	<b>3.1</b> Temperature control incorrect setting.	<b>3.1.1</b> Turn clockwise.
	<b>3.2</b> Setup link fitted on a lower temperature setting.	<b>3.2.1</b> Isolate unit at isolating switch. Re-position setup link onto higher temperature pins (see 'Setup link procedure'). Re-adjust the temperature control.
	<b>3.3</b> Unit malfunction.	<b>3.3.1</b> Contact Customer Service for advice.
<b>4.</b> Unstable shower temperature/flow.	<b>4.1</b> Blockages	<b>4.1.1</b> Clean sprayhead. Check inlet filter in solenoid and clean if necessary.
	<b>4.2</b> Loose PCB connection	<b>4.2.1</b> Check electrical connections on PCB's are correctly fitted.
	<b>4.3</b> Unit malfunction.	<b>4.3.1</b> Contact Customer Service for advice.
<b>5</b> Pressure relief device has operated (water from PRD tube). <b>Note:-</b> Identify cause of operation before fitting new PRD unit. When fitting new PRD, follow commissioning procedure.	<b>5.1</b> Blocked sprayhead.	<b>5.1.1</b> Clean or replace blocked sprayhead cartridge and then fit a new PRD.
	<b>5.2</b> Twisted/blocked flexible shower hose.	<b>5.2.1</b> Check for free passage through hose. Replace the hose if necessary, then fit new PRD.
	<b>5.3</b> Sprayhead not removed whilst commissioning.	<b>5.3.1</b> Fit new PRD. Commission unit with sprayhead removed.
<b>6</b> Unit fails to turn off and water flowing. LED's flashing in sequence.	<b>6.1</b> Link pin has not been removed from the 'purge' position or is incorrectly positioned.	<b>6.1.1</b> Isolate unit at isolating switch. Re-position setup link onto correct temperature pins (see 'Setup link procedure').
<b>7</b> Water continues to flow when unit is isolated at the isolating switch.	<b>7.1</b> Debris in solenoid.	<b>7.1.1</b> Contact Customer Service for advice.
<b>8</b> Medium LED flashing continuously unit switches off.	<b>8.1</b> Faulty inlet or outlet sensor.	<b>8.1.1</b> Contact Customer Service.
<b>9</b> Low LED flashing continuously unit switches off.	<b>9.1</b> Low water pressure.	<b>9.1.1</b> Wait for water pressure to return to normal, restart unit.
	<b>9.2</b> Faulty flow turbine.	<b>9.2.1</b> Contact Customer Service.
	<b>9.3</b> Blocked inlet filter.	<b>9.3.1</b> Clean the filter in solenoid.
	<b>9.4</b> Blocked sprayhead.	<b>9.4.1</b> Clean the sprayhead.

In the unlikely event of unit failure other than detailed in the fault finding page, please contact Customer Service for advice.

It is advised all electrical maintenance/repairs to the shower should be carried out by a suitably qualified person.

**WARNING**

Before proceeding with any repair work or fault finding exercise, be aware that the printed circuit boards in this unit are static electricity sensitive and must be treated with great care. In order to prevent damage to the p.c.b.'s, a static control wrist strap must be worn before handling or removing the printed circuit boards.



## TRITON STANDARD GUARANTEE

Triton Plc guarantee this product against all mechanical and electrical defects arising from faulty workmanship or materials for a period of two years for domestic use only, from the date of purchase, provided that it has been installed by a competent person in full accordance with the fitting instructions.

Any part found to be defective during this guarantee period we undertake to repair or replace at our option without charge so long as it has been properly maintained and operated in accordance with the operating instructions, and has not been subject to misuse or damage.

This product must not be taken apart, modified or repaired except by a person authorised by Triton Plc. This guarantee applies only to products installed within the United Kingdom and does not apply to products used commercially.

This guarantee does not affect your statutory rights.

### *What is not covered:*

**1** Breakdown due to: **a)** use other than domestic use by you or your resident family; **b)** wilful act or

neglect; **c)** any malfunction resulting from the incorrect use or quality of electricity, gas or water or incorrect setting of controls; **d)** faulty installation.

**2** Repair costs for damage caused by foreign objects or substances.

**3** Total loss of the product due to non-availability of parts.

**4** Compensation for loss of use of the product or consequential loss of any kind.

**5** Call out charges where no fault has been found with the appliance.

**6** The cost of repair or replacement of pressure relief devices, sprayheads, hoses, riser rails and/or wall brackets, isolating switches, electrical cable, fuses and/or circuit breakers or any other accessories installed at the same time.

**7** The cost of routine maintenance, adjustments, overhaul modifications or loss or damage arising therefrom, including the cost of repairing damage, breakdown, malfunction caused by corrosion, furring, pipe scaling, lime scale, system debris or frost.

## Service Policy

In the event of a complaint occurring, the following procedure should be followed:

**1** Telephone Customer Service on (024) 7637 2222 (08457 626591 in Scotland and in Northern Ireland), having available the model number and power rating of the product, together with the date of purchase.

**2** Triton Customer Service will be able to confirm whether the fault can be rectified by either the provision of a replacement part or a site visit from a qualified Triton service engineer.

**3** If a service call is required it will be booked and the date of call confirmed. In order to expedite your request, please have your postcode available when booking a service call.

**4** It is essential that you or an appointed representative (who must be a person of 18 years of age or more) is present during the service engineer's visit and receipt of purchase is shown.

**5** A charge will be made in the event of an aborted service call by you but not by us, or where a call under the terms of guarantee has been booked and the failure is not product related (i.e. scaling and furring, incorrect water pressure, pressure relief device operation, electrical installation faults).

**6** If the product is no longer covered by the guarantee, a charge will be made for the site visit and for any parts supplied.

**7** Service charges are based on the account being settled when work is complete, the engineer will then request payment for the invoice. If this is not made to the service engineer or settled within ten working days, an administration charge will be added.

## Replacement Parts Policy

*Availability:* It is the policy of Triton to maintain availability of parts for the current range of products for supply after the guarantee has expired. Stocks of spare parts will be maintained for the duration of the product's manufacture and for a period of five years thereafter.

In the event of a spare part not being available a substitute part will be supplied.

*Payment:* The following payment methods can be used to obtain spare parts:

**1** By post, pre-payment of pro forma invoice by cheque or money order.

**2** By telephone, quoting credit card (MasterCard or Visa) details.

**3** By website order, [www.tritonshowers.co.uk](http://www.tritonshowers.co.uk)

Triton Plc, Shepperton Park, Caldwell Road,  
Nuneaton, Warwickshire. CV11 4NR

### Customer Service

☎ (024) 7637 2222

### Scottish and Northern Ireland

### Customer Service

☎ 08457 626591

### Trade Installer Hotline

☎ (024) 7632 5491

Fax: (024) 7632 4564

[www.tritonshowers.co.uk](http://www.tritonshowers.co.uk)

E mail: [technical@triton.plc.uk](mailto:technical@triton.plc.uk)