

Aspirante Electric



Installation and Operating Instructions

INSTALLERS PLEASE NOTE THESE INSTRUCTIONS ARE TO BE LEFT WITH THE USER

CONTENTS	Page
Important safety information	1
Introduction	2
Advice to users	2
Key to main components	3
Electrical requirements	4 - 5
Water requirements	6
Siting of the shower	6 - 7
Fitting the shower to the wall	8
Plumbing connections	8 - 9
Electrical connections	10
Replacing the cover	11
Commissioning	12
Operating the shower	13 - 14
Operating functions	14 - 15
Adjusting the sprayhead	15
Cleaning	16
Cleaning the filter	17
Spare parts	18
Temperature / flow rate graph	19
Fault finding	20 - 21
Guarantee, service policy, etc.	rear cover

To ensure the product suitability for commercial and multiple installations, please contact Triton's specification advisory service prior to installation.

Telephone: (024) 7632 5491

Facsimile: (024) 7632 4564

E mail: technical@triton.plc.uk

PLEASE READ THIS IMPORTANT SAFETY INFORMATION

- ◆ Products manufactured by Triton are safe and without risk provided they are installed, used and maintained in good working order in accordance with our instructions and recommendations.
- ◆ DO NOT operate shower if frozen, or suspected of being frozen. It must thaw out before using.
- ◆ DO NOT operate the unit if the sprayhead or spray hose becomes damaged.
- ◆ DO NOT restrict flow out of the shower by placing sprayhead in direct contact with your body.
- ◆ DO NOT operate the shower if water ceases to flow during use or if water has entered inside the unit because of an incorrectly fitted cover.
- ◆ WARNING: If re-starting the shower immediately after stopping, be aware that a slug of hot water will be expelled for the first few seconds.

1 GENERAL

- 1.1 Isolate the electrical and water supplies before removing the cover.
- 1.2 Read all of these instructions and retain them for later use.
- 1.3 DO NOT take risks with plumbing or electrical equipment.
- 1.4 Isolate electrical and water supplies BEFORE proceeding with the installation.
- 1.5 The unit must be mounted onto the finished wall surface (on top of the tiles). DO NOT tile up to unit after fixing to wall.
- 1.6 Contact Customer Service (see back page), if any of the following occur;
 - a) If it is intended to operate the shower at pressures above the maximum or below the minimum stated.
 - b) If the unit shows a distinct change in performance.
 - c) If the shower is frozen.
- 1.7 If it is intended to operate the shower in areas of hard water (above 200 ppm temporary hardness), a scale inhibitor may have to be fitted. For advice on the Triton Scale Inhibitor, contact Triton Customer Service.
- 1.8 The sprayplate and cartridge must be cleaned regularly with descalant to remove scale and debris, otherwise restrictions to the flow on the outlet of the unit will result in higher temperatures and could also cause the Pressure Relief Device in unit to operate.
- 1.9 This product is not suitable for mounting into steam rooms or steam cubicles.

2 PLUMBING

- 2.1 The plumbing installation must comply with Water Regulations, Building Regulations or any particular regulations as specified by Local Water Company or Water Undertakers and should be in accordance with BS 6700.
- 2.2 The supply pipe must be flushed to clear debris before connecting to the shower unit.
- 2.3 DO NOT solder pipes or fittings within 300mm of shower, as heat transfer can damage components.

- 2.4 DO NOT fit any form of outlet flow control as the outlet acts as a vent for the heater can.
- 2.5 DO NOT use excessive force when making connections to the flexible hose or sprayhead, finger tightness is sufficient.
- 2.6 All plumbing connections MUST be completed BEFORE making the electrical connections.

3 ELECTRICAL

- 3.1 The installation must comply with BS 7671 'Requirements for electrical installations' (IEE wiring regulations) or any particular regulations as specified by the local Electrical Supply Company.
- 3.2 This appliance MUST be earthed.
- 3.3 In accordance with 'The Plugs and Sockets etc. (Safety) Regulations 1994', this appliance is intended to be permanently connected to the fixed wiring of the electrical mains system.
- 3.4 Ensure all electrical connections are tight to prevent overheating.
- 3.5 Fuses do not give personal protection against electric shock.
- 3.6 *To enhance electrical safety* a 30mA residual current device (RCD) should be installed in all UK electric and pumped shower circuits. This may be part of the consumer unit or a separate unit.
- 3.7 Switch off immediately at isolating switch if water ceases to flow during use.
- 3.8 Other electrical equipment i.e. extractor fans, pumps must not be connected to the circuits within the unit.
- 3.9 Switch off at isolating switch when not in use. This is a safety procedure recommended with all electrical appliances.
- 3.10 As with all electrical appliances it is recommended to have the shower and installation checked at least every two years by a competent electrician to ensure there is no deterioration due to age and usage.

INTRODUCTION

This book contains all the necessary fitting and operating instructions for your Aspirante electric shower.

Take time to read this book thoroughly and familiarise yourself with all instructions **before** commencing installation. Please keep it for future reference.

The shower installation must be carried out by a suitably qualified person and in the sequence of this instruction book.

Care taken during the installation will ensure a long, trouble-free life from your shower.

SPECIFICATIONS

Electrical

Nominal power rating at 240V	Nominal power rating at 230V
8.5kW – (40A MCB rating)	7.8kW – (40A MCB rating)
9.5kW – (40A MCB rating)	8.7kW – (40A MCB rating)
10.5kW – (45A MCB rating)	9.6kW – (45A MCB rating)

Water

Inlet connection – 15mm diameter.

Outlet connection – 1/2" BSP male thread.

Entry Points

Water – top, bottom or back.

Cable – top, bottom or back.

Materials

Backplate, cover, controls, sprayhead – ABS.

Sprayplate – Acetal.

Elements – Minerally insulated corrosion resistant metal sheathing.

Dimensions

Height - 300mm

Width - 208mm

Depth - 110mm

Standards and Approvals

Splashproof rating IPX4.

Complies with the requirements of current British and European safety standards for household and similar electrical appliances.

Complies with requirements of the British Electrotechnical Approvals Board (BEAB).

Meets with Compliance with European Community Directives (CE).

ADVICE TO USERS

The following points will help you understand how the shower operates:

A The electric heating elements operate at a constant rate at your chosen power setting. It is the flow rate of the water passing through the heater unit which determines the shower temperature at any given setting. (The slower the flow the hotter the water becomes, and the faster the flow the cooler the water).

B During Winter, mains water supply will be cooler than in Summer. Therefore the temperature of the shower will vary between seasons on any one setting of the temperature control, e.g. if you have chosen setting number 6 as your preferred shower temperature in the Summer, you will have to increase that number during Winter by adjusting the temperature control clockwise (which in effect slows the water flow).

C The stabiliser valve minimises variations in shower temperature during mains water pressure changes. If changes in shower temperature are experienced during normal use, it will most likely be caused by the water pressure falling near to or below the minimum level. The drop in pressure may be due to water being drawn off at other points in the house whilst the shower is in use. If pressure drops appreciably below the minimum, the heating elements will automatically cut out.

If ever the water becomes too hot and you cannot obtain cooler water, first check that the sprayplate in the sprayhead has not become blocked.

DO NOT place items such as soap or shampoo bottles on top of the unit. Liquid could seep through the joint between the cover and backplate, and possibly damage the sealing rubber.

Replacement parts can be ordered from Customer Service. See 'spare parts' for details and part numbers.

Due to continuous improvement and updating, specification may be altered without prior notice.

KEY TO MAIN COMPONENTS

Inside unit (fig.1)

- 1 Top cable/pipe entry
- 2 Wall screw fixings
- 3 Cover screw fixings
- 4 Thermal safety cut-out
- 5 Power selector assembly
- 6 Can and element assembly
- 7 Pressure switch/flag assembly
- 8 Stabilising valve
- 9 Terminal block
- 10 Earth connection
- 11 Solenoid valve
- 12 Water inlet
- 13 Thermal cut-out (outlet)
- 14 Pressure relief device (PRD)
- 15 Shower outlet
- 16 Outlet earth spring

Inside cover (fig.2)

- 17 Stop/start switch

Pack contents

- Shower unit
- Four position sprayhead
- Screw fixing kit
- Instructions, guarantee, etc.

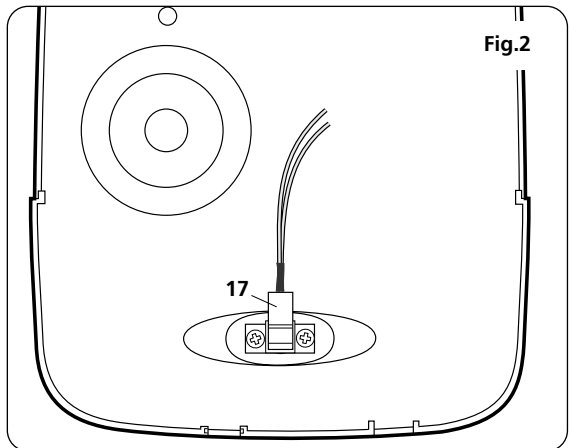
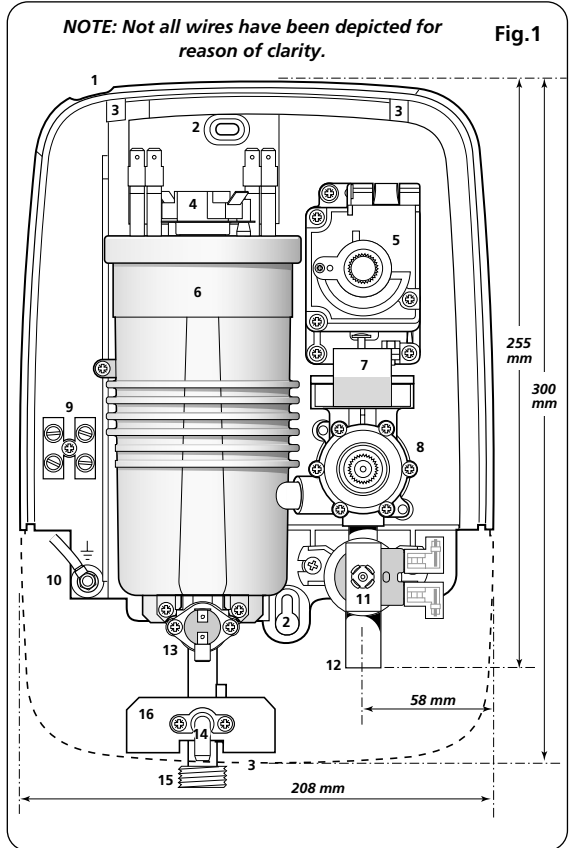

ELECTRICAL REQUIREMENTS

WARNING

THIS APPLIANCE MUST BE EARTHED

The installation, supply cable and circuit protection must conform with IEE wiring regulations and be sufficient for the amperage required.

The following notes are for guidance only:

1 The shower must only be connected to a 230-240V ac supply. If you are installing a shower with a kilowatt rating above 9kW, it is advisable to contact the local electricity supply company.

1.1 The electrical rating of the shower is shown on the rating label (**fig.3**) within the unit.

2 Before making any sort of electrical connection within the installation, ensure that no terminal is live. If in any doubt, switch off the whole installation at the consumer unit.

3 The shower must be connected to its own independent electrical circuit. IT MUST NOT be connected to a ring main, spur, socket outlet, lighting circuit or cooker circuit.

3.1 The electrical supply must be adequate for the loading of the unit and existing circuits.

4 Check your consumer unit (main fuse box) has a main switch rating of 80A or above and that it has a spare fuse way which will take the fuse or mcb necessary for the shower (**fig.4**).

4.1 If your consumer unit has a rating below 80A or if there is no spare fuse way, then the installation will not be straight forward and may require a new consumer unit serving the house or just the shower.

4.2 You will need to contact the local electricity company. They will check the circuit and carry out what is necessary. They will also check the main bonding.

5 The earth continuity conductor of the electrical installation must be effectively connected electrically to all exposed metal parts of other appliances and services in the room in which the shower is to be installed, to conform to current IEE regulations.



Fig.3

Fig.4 schematic of installation circuit

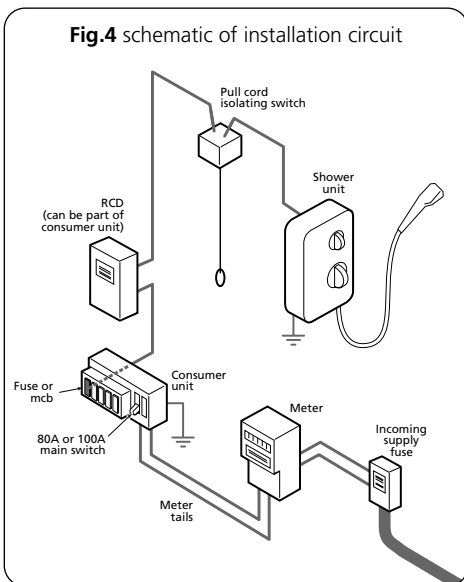

Table A

CIRCUIT PROTECTION		
unit rating	mcb	cartridge fuse
7.0kW	30/32A	30A
7.5kW	32A	35A
8.0kW	40A	35A
8.5kW	40A	45A
9.0kW	40A	45A
9.5kW	40/45A	45A
10.5kW	45A	45A

ELECTRICAL REQUIREMENTS

5.1 All exposed metallic parts in the bathroom must be bonded together using a cable of at least 4mm² cross sectional area. These parts include metal baths, radiators, water pipes, taps and waste fittings.

6 For close circuit protection DO NOT use a rewirable fuse. Instead use a suitably rated miniature circuit breaker (MCB) or cartridge fuse (see table A).

6.1 In the interest of electrical safety a 30mA residual current device (RCD) should be installed in all UK electric and pumped shower circuits. This may be part of the consumer unit or a separate unit.

7 A 45 amp double pole isolating switch with a minimum contact gap of 3mm in both poles must be incorporated in the circuit.

7.1 It must have a mechanical indicator showing when the switch is in the OFF position, and the wiring must be connected to the switch without the use of a plug or socket outlet.

7.2 The switch must be accessible and clearly identifiable, but out of reach of a person using a fixed bath or shower, except for the cord of a

cord operated switch, and should be placed so that it is not possible to touch the switch body while standing in a bath or shower cubicle. It should be readily accessible to switch off after using the shower.

8 Where shower cubicles are located in any rooms other than bathrooms, all socket outlets in those rooms must be protected by a 30mA RCD.

9 The current carrying capacity of the cable must be at least that of the shower circuit protection (see table B).

9.1 To obtain full advantage of the power provided by the shower, use the shortest cable route possible from the consumer unit to the shower.

9.2 It is also necessary to satisfy the disconnection time and thermal constraints which mean that for any given combination of current demand, voltage drop and cable size, there is a maximum permissible circuit length.

10 The shower circuit should be separated from other circuits by at least twice the diameter of the cable or conduit.

10.1 The current rating will be reduced if the cabling is bunched with others, surrounded by thermal loft or wall insulation or placed in areas where the ambient temperature is above 30°C. Under these conditions, de-rating factors apply and it is necessary to select a larger cable size.

10.2 In the majority of installations, the cable will unavoidably be placed in one or more of the above conditions. This being so, it is strongly recommended to use a minimum of 10mm cabling throughout the shower installation.

10.3 In any event, it is essential that individual site conditions are assessed by a competent electrician in order to determine correct cable size and permissible circuit length.

Table B

**Twin and earth PVC insulated cable
CURRENT CARRYING CAPACITY**

installed in an insulated wall	in conduit or trunking	clipped direct or buried in a non insulated wall
6mm ²	6mm ²	6mm ²
32A	38A	46A
10mm ²	10mm ²	10mm ²
43A	52A	63A
16mm ²	16mm ²	16mm ²
57A	69A	85A

Note: Cable selection is dependent on de-rating factors

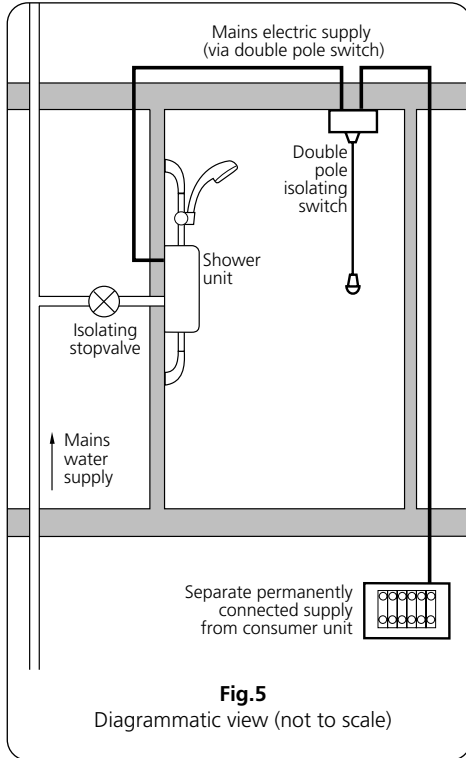

Fig.5

Diagrammatic view (not to scale)

WATER REQUIREMENTS

The installation must be in accordance with Water Regulations/Byelaws.

To ensure activation of the heating elements, the shower must be connected to a mains water supply with a minimum running pressure of 100 kPa (1.0 bar) at a minimum flow rate of eight litres per minute for the 8.5kW rated model and nine litres per minute for the 9.5kW rated model.

For the 10.5kW rated shower, the minimum running pressure must be 150 kPa (1.5 bar) at a minimum flow rate of eleven litres per minute. All models must have a maximum static pressure of 1,000 kPa (10 bar).

NOTE: If the stated flow rates are not available, it may not be possible to achieve optimum performance from the unit throughout the year.

During periods of high ambient temperatures it may be necessary to select a low power setting to achieve your preferred shower temperature.

The water supply can be taken from a cold water storage cistern provided there is a minimum head of ten metres (fifteen metres for the 10.5kW shower) above the sprayhead. It must be an independent supply to the shower only.

If it is intended to operate the shower at pressures above the maximum or below the minimum stated, contact Customer Service for advice.

Fig.5 shows a typical system layout.

Do not use jointing compounds on any pipe fittings for the installation.

SITING OF THE SHOWER

WARNING: The shower must not be positioned where it will be subjected to freezing conditions.

FOR EASE OF SERVICING, THE UNIT MUST ALWAYS BE MOUNTED ON THE SURFACE OF TILED WALLS. NEVER TILE UP TO THE UNIT.

Refer to **figure 6** for correct siting of shower. Position the unit where it will NOT be in direct contact with water from the sprayhead. Position the shower unit vertically.

Allow sufficient room between the ceiling and the shower to access the cover top screws.

NOTE: Water regulations require the sprayhead be

'constrained by a fixed or sliding attachment so that it can only discharge water at a point not less than 25mm above the spill-over level of the relevant bath, shower tray or other fixed appliance'. The use of a retaining ring will in most cases meet this requirement, but if the sprayhead can be placed within a bath, basin or shower tray, then a double check valve, or similar, must be fitted in the supply pipework to prevent back-flow.

Pressure relief safety device

A pressure relief device (PRD) is designed into the shower unit which complies with European standards. The PRD provides a level of appliance protection should an excessive build up of pressure occur within the shower. DO NOT operate the shower with a damaged or kinked shower hose, or a blocked sprayhead which can cause the PRD to operate.

When commissioning, the sprayhead must be removed from the flexible hose, while at the same time the temperature control must be at the minimum flow position. Failure to follow this procedure may also cause the PRD to operate.

Ensure the shower is positioned over a bath or shower tray because if the PRD operates, then water will eject from the bottom of the unit. Should this happen, turn off the electricity and water supplies to the shower at the isolating switch and stopvalve. Contact Customer Service for advice on replacing the PRD.

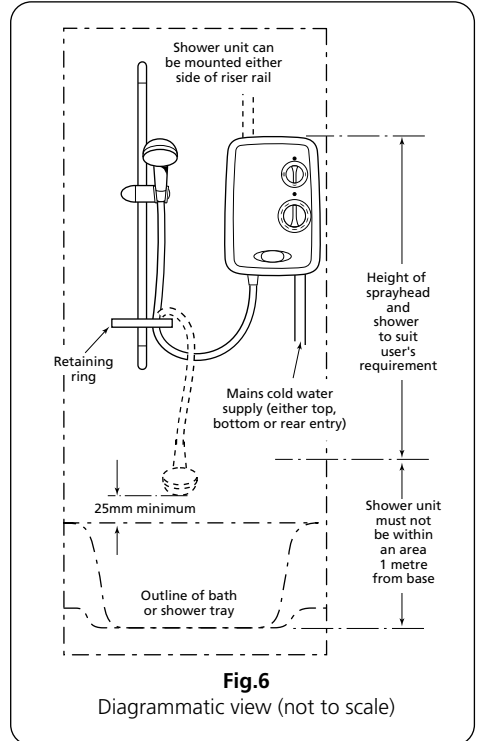

Important: The unit must be mounted on a flat surface which covers the full width and length of the backplate. It is important that the wall surface is flat otherwise difficulty may be encountered when fitting the cover and subsequent operation of the unit may be impaired.



FITTING THE SHOWER TO WALL

NOTE: The control knobs are an integral part of the cover – do not attempt to remove them.

The three retaining screws that will hold the cover in place (**fig.7**) are packed within the box. Note the top two cover screws are M3 machine screws and the bottom screw is a self tapping screw.

Inspect the unit to ensure the main earthing spring on the outlet pipe is not damaged.

Entry positions for the mains water and electric cable are from the top, bottom, or from the back.

NOTE: Deviations from the designated entry points will invalidate product approvals.

If bottom entry has been chosen, fit the appropriate cut-out in the top of the backplate (**fig.8**).

If top entry has been chosen, fit the appropriate cut-out in the bottom of the cover (**fig.9**).

If installing a feed pipe from the back or bottom, the centre of the inlet valve to the wall surface is 20mm (**fig.10**).

NOTE: If entry is from the back, the nut of the compression fitting will be partially behind the surface of the wall (**fig.10**). This area MUST be left clear when plastering over the pipework in order to make the nut accessible for future adjustments.

After choosing the site for the shower, use the backplate as a template and mark the two fixing holes (**fig.11**). Drill and plug to suit the fixing screws supplied.

(The wallplugs provided are suitable for most brick walls – use an appropriate masonry drill, but if the wall is plasterboard or a soft building block, you must use special wallplugs and an appropriate drill obtainable from most hardware stores).

Screw the bottom fixing screw into position leaving the base of the screw head protruding 6mm (0.25in) out from the wall.

Hook the backplate over the bottom screw and fit the top fixing screw into position.

Do not fully tighten the screws at this stage, as the fixing holes are elongated to allow for out of square adjustment after the plumbing connections have been completed.

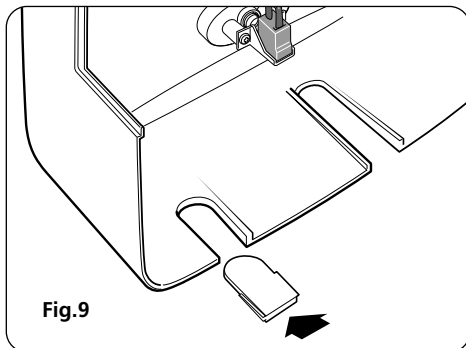
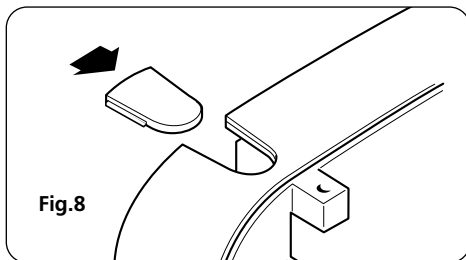

PLUMBING CONNECTIONS

Plumbing to precede wiring.

WARNING: The outlet of the shower acts as a vent and must not be connected to anything other than the hose and sprayhead supplied.

DO NOT use jointing compounds on any pipe fittings for the installation.

DO NOT use soldered fittings within the vicinity of the shower unit.

Compression fittings **MUST** be used to connect to the inlet of the shower.

NOTE: An additional stopvalve (complying with Water Regulations) **MUST** be fitted in the mains water supply to the shower as an independent means of isolating the water in order to carry out maintenance or servicing.

Important: Before completing the connection of the water supply to the inlet of the shower, flush out the pipework to remove all swarf and system debris. This can be achieved by connecting a hose to the pipework and turning on the mains water supply long enough to clear the debris to waste.

Procedure: Turn off water supply either at the mains stopvalve or the isolating stopvalve. Connect the mains water supply to the inlet of the shower via 15mm copper, stainless steel or plastic pipe using a 15mm x 15mm compression fitting.

NOTE: The inlet fitting is designed to enter a compression fitting only. **DO NOT** use push fit connectors as full engagement cannot be guaranteed.

DO NOT use excessive force when making these connections.

Ensure the backplate is square on the wall and tighten the two retaining screws which hold it to the wall.

Turn on the mains water supply and check for leaks in the pipework connection to the shower.

NOTE: At this stage no water can flow through the unit.

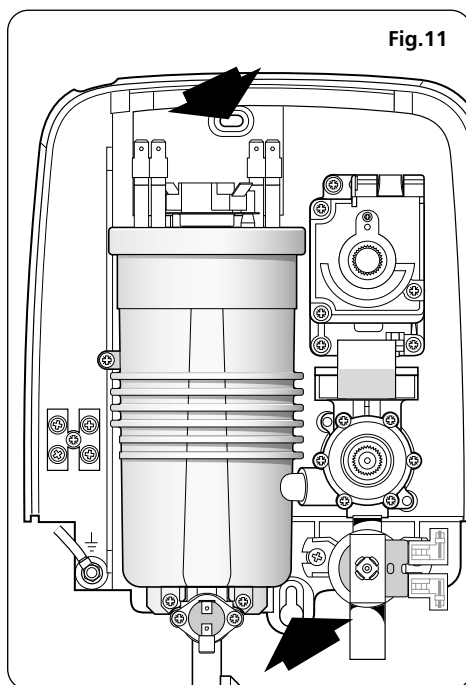
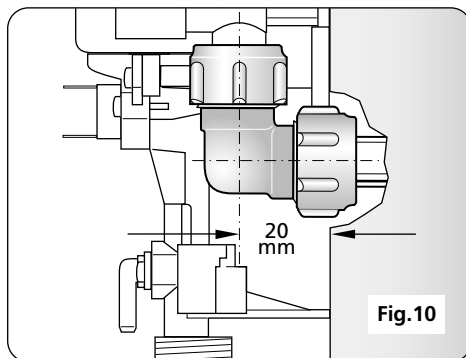
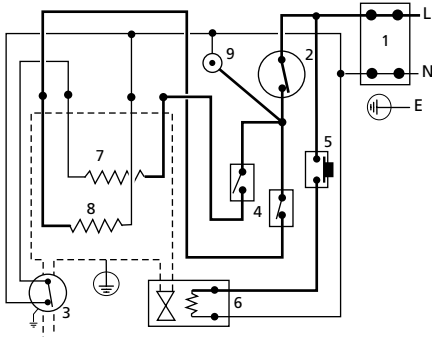
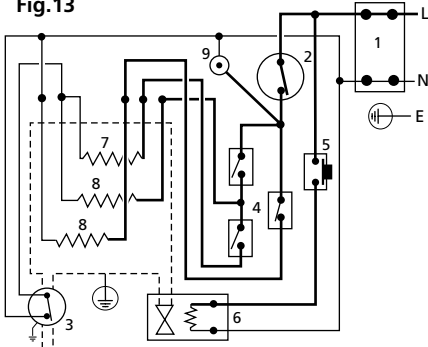

Fig.12



- | | |
|----------------------------|------------------|
| 1 Terminal block | 6 Solenoid valve |
| 2 Thermal cut-out (main) | 7 Element |
| 3 Thermal cut-out (outlet) | 8 Element |
| 4 Microswitches | 9 Neon |
| 5 Start/stop button | |

Fig.13



ELECTRICAL CONNECTIONS

SWITCH OFF THE ELECTRICITY SUPPLY.

Fig.12 shows a schematic wiring diagram for the 8.5kW and 9.5kW units.

Fig.13 is the diagram for the 10.5kW unit.

The cable can be surface clipped, hidden or via 20mm conduit. NOTE: Conduit entry can only be from rear. Route the cable into the shower unit and connect to the terminal block (fig.14) as follows:-

Earth cable to terminal marked **E** 

Neutral cable to terminal marked **N**

Live cable to terminal marked **L**

IMPORTANT: Fully tighten the terminal block screws and ensure that no cable insulation is trapped under the screws. Loose connections can result in cable overheating

NOTE: The supply cable earth conductor must be sleeved. The outer sheath of the supply cable must be stripped back to the minimum.

The supply cable must be secured either by routing through conduit or in trunking or by embedding in the wall, in accordance with IEE regulations.

The use of connections within the unit, or other points in the shower circuit, to supply power to other equipment i.e. extractor fans, pumps etc. will invalidate the guarantee.

DO NOT switch on the electricity supply until the cover has been fitted.

Terminal block

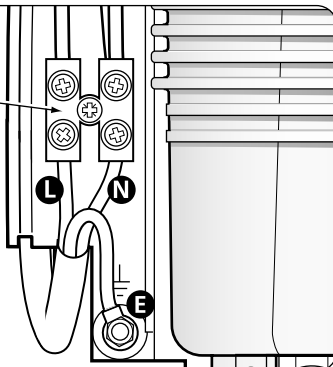

Fig.14

NOTE: The elements on UK models are to 240V specification and will give a lower kW rating if the voltage supply is below 240V.

REPLACING THE COVER

Inspect the earth spring contact to ensure it has not been damaged during installation.

The power selector spindle must be aligned as shown (**fig.15**).

To ensure that the temperature control is correctly positioned on the stabilising valve, temporarily place the cover in position so that the splines engage and rotate the temperature control fully anti-clockwise.

Remove the cover and position the temperature control knob so that it points towards the No.1 position (**fig.16**).

Position the power selector to the 'COLD' position (**fig.17**).

Offer the cover to the backplate unit. Attached to the stop/start switch inside the cover is a two wire lead. The socket on the end of this lead must be connected to the plug that is situated at the bottom of the right hand side of the backplate unit (**fig.18**). NOTE: The plug and socket can only fit one way.

Replace the cover squarely to the backplate and guide into position so that the knobs locate correctly into the splined spindles while at the same time, ensuring wires are not trapped.

Should any difficulty arise, re-check the points above.

Secure the cover in position with the three retaining screws.

NOTE: The two screws used to secure the top of the cover differ from the third screw used to secure the bottom of the cover.

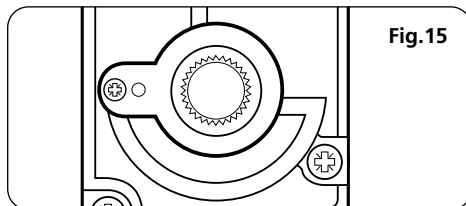

Fig.15

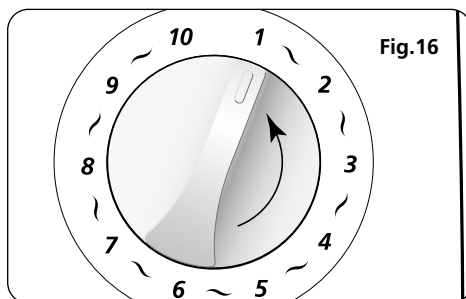

Fig.16

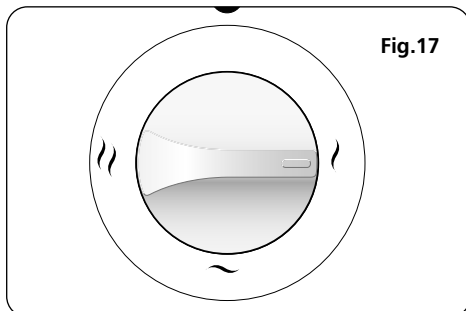

Fig.17

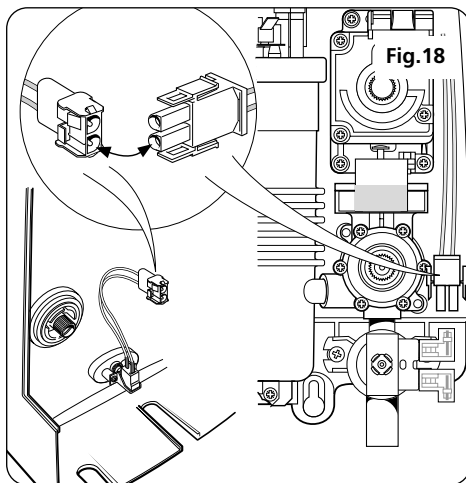

Fig.18

Fig.19

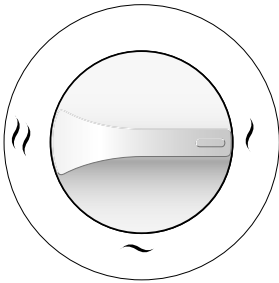

Fig.20

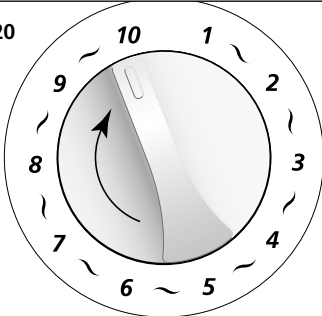

Fig.21

start / stop

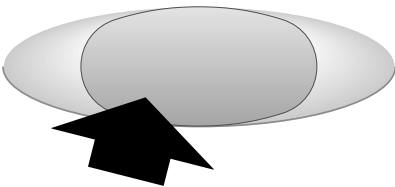
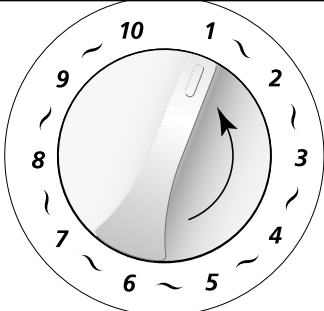

Fig.22



COMMISSIONING

The first operation of the shower is intended to flush out any remaining unit debris, and to ensure the heater unit contains water before the elements are switched on. This operation must be carried out with the flexible hose screwed to the outlet but *without* the sprayhead attached. The 'COLD' position must be used. Ensure the outlet of the flexible hose is directed to waste.

NOTE: Ensure the 'START/STOP' button is not depressed in the cover which indicates 'start'. The button should be flush with the cover, otherwise water will flow as soon as the electricity is switched on.

Before turning on the electric and mains water supplies to the shower, ensure that the power selector is at the 'COLD' position (**fig.19**) and the temperature control is rotated fully clockwise to '10', the minimum flow position (**fig.20**).

NOTE: Failure to turn the control to '10' may cause the PRD to operate.

Turn on the mains water supply to the shower at the isolating stop valve and then turn on the electric supply to the shower at the isolating switch. The power indicator will light.

Press the 'START/STOP' button (fig.21) and wait until water starts to flow from the flexible hose.

Slowly rotate the temperature control fully anti-clockwise to '1', the maximum flow position (**fig.22**).

It will take approximately thirty seconds for a smooth flow of water to be obtained whilst air and debris is being dispersed from the shower.

When a smooth flow of water is obtained, rotate the temperature control from '1' to '10' several times to release any trapped air within the unit.

Once flushing out has been completed, stop the water flow by pressing the 'START/STOP' button.

Fit the sprayhead to the flexible hose and place in the sprayhead holder. The shower is now ready for normal operation.

OPERATING THE SHOWER

NOTE: Ensure the commissioning procedure has been carried out.

To start the shower

Press the 'START/STOP' button and water will flow.

To stop the shower

Press the 'START/STOP' button and water will cease to flow.

CAUTION: If re-starting immediately after stopping, be aware that a slug of hot water will be expelled for the first few seconds.

To use the power selector

The power selector has three positions (cold, economy and high) as shown in **fig.23**.

Blue symbol is cold water only. Adjustment of the temperature control at this setting will only alter the force of the water from the sprayhead. IT WILL NOT ALTER THE WATER TEMPERATURE.

Single red symbol is an economy setting for using less power when the ambient mains water temperature is high during hot months.

Temperature adjustment at this setting is via the temperature control.

NOTE: If the stated flow rate required for the unit cannot be met due to low water pressure, it will be necessary to operate the unit on this setting during the warmer months because of flow rate limitations entering the unit.

Double red symbol is a high setting which allows the highest flow achievable for your preferred temperature. This setting should normally be regarded as optimum shower performance throughout the year. Temperature adjustment at this setting is via the temperature control.

To adjust the shower temperature

The water temperature is altered by increasing or decreasing the flow rate of the water through the shower via the temperature control (**fig.23**).

After obtaining your preferred shower temperature, the number can be remembered and left as the normal setting and should only need to be altered to compensate for seasonal changes in ambient water temperature.

NOTE: The preferred number on 'economy' will give a different temperature to the same number position on 'high'.

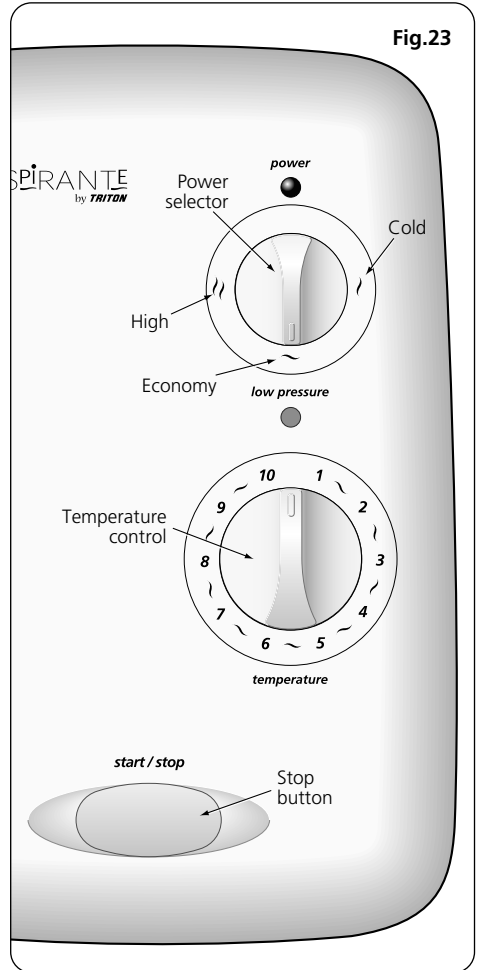

NOTE: IN NORMAL USE, IT IS IN ORDER TO LEAVE THE WATER SUPPLY PERMANENTLY ON TO THE SHOWER UNIT, BUT AS WITH MOST ELECTRICAL APPLIANCES, **THE UNIT MUST BE SWITCHED OFF AT THE ISOLATING SWITCH WHEN NOT IN USE.**

Fig.24

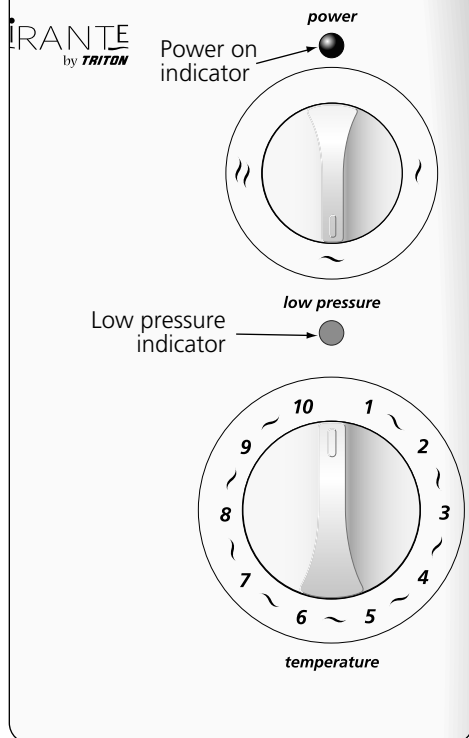
**To decrease the shower temperature**

Turn the temperature control anti-clockwise; this will increase the flow of water through the shower and be indicated by the lower numbers.

To increase the shower temperature

Turn the temperature control clockwise; this will decrease the flow of water through the shower and be indicated by the higher numbers.

NOTE: It is advisable to be certain that the showering temperature is satisfactory by testing with your hand before stepping under the sprayhead. There will always be a time delay of ten to fifteen seconds between selecting a flow rate and the water reaching the stable temperature for that flow rate.

CAUTION: It is recommended that persons who may have difficulty understanding or operating the shower controls should not be left unattended whilst showering. Special consideration should be given to young children and the less able bodied.

WARNING: After any servicing of the mains water supply, always ensure the unit is started on COLD in order to purge any air in the pipework.

OPERATING FUNCTIONS**Power on indicator (fig.24)**

When the electricity supply to the shower is switched on at the isolating switch, the 'power' indicator will light.

Low pressure indicator (fig.24)

A red indication means the water pressure has fallen below the minimum required for correct operation of the shower. In this state the low pressure cut-out has operated. This switches off power to the heating elements preventing maintained temperature rises (water will continue to flow). Power will automatically be restored when adequate water pressure returns. If the indication fluctuates between red and green, this means the pressure is only just sufficient and operating difficulties may be encountered.

A green indication shows that water pressure is sufficient for satisfactory operation of the shower.

Overheat cut-out

During normal operation if an overheat temperature is sensed, power to the elements will

be reduced. Water will continue to flow. When the temperature has cooled sufficiently, power to the elements will be automatically restored to the previous setting at the time of interruption.

Safety cut-out

The unit is fitted with a non re-settable over-temperature safety device. In the event of abnormal operation which could cause unsafe temperatures within the unit, the device will disconnect the heating elements. It will require a visit from a qualified engineer to determine the nature of the fault and replace the safety device, once the unit has been repaired.

ADJUSTING THE SPRAYHEAD

Four sprayhead patterns are available (**fig.25**). Adjustment is by turning the bezel on the sprayhead in either direction until the desired pattern is obtained.

Maxi: A full spray perfect for a relaxing shower.

Ultra: A focused spray for a refreshing, satisfying shower.

Needle: A tingling, fine spray for a highly invigorating shower.

Jet: A concentrated spray for an exhilarating shower.

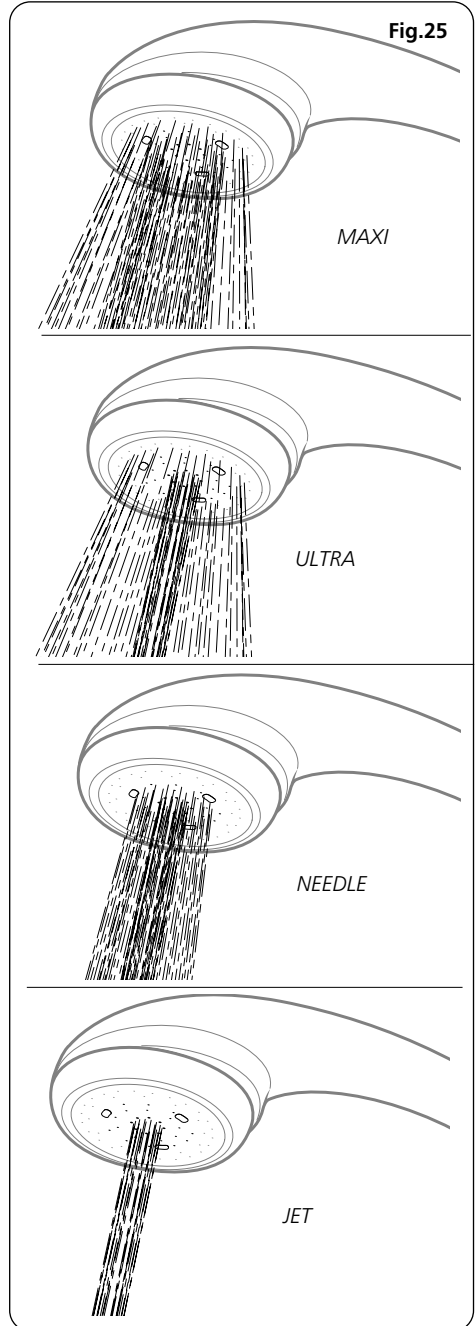

CLEANING

Fig.26

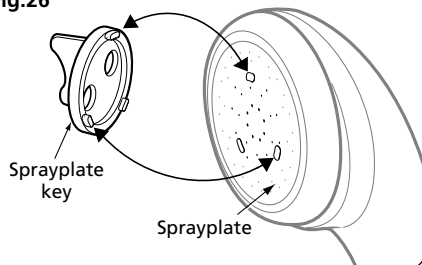

Fig.27

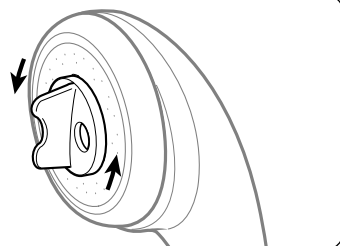
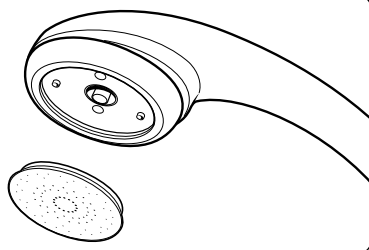

Fig.28



DO NOT use abrasive or solvent cleaning fluids on this product.

The shower unit and riser rail should be wiped down with a soft cloth and water. A special 'E-Cloth' has been developed for Triton for this purpose. For details contact Customer Service. Tel: (024) 7637 2222.

It is advised before cleaning, to turn the isolation switch off, thus avoiding the shower being accidentally switched on.

IT IS IMPORTANT TO KEEP THE SPRAYHEAD CLEAN TO MAINTAIN THE PERFORMANCE OF THE SHOWER. The hardness of the water will determine the frequency of cleaning. For example, if the shower is used every day in a very hard water area, it may be necessary to clean the sprayhead on a weekly basis.

Sprayplate removal

There is no need to remove the sprayhead from the hose.

Using the removal tool supplied (**fig.26**), locate the three raised 'bosses' into the three recesses in the sprayplate. Hold in firmly and twist anti-clockwise (**fig.27**). This movement may turn the cartridge assembly as well until it reaches a 'stop'. Hold the cartridge firmly and continue to twist anti-clockwise. Having loosened the sprayplate sufficiently, it can be unscrewed and removed completely (**fig.28**).

Clean the sprayplate with a suitable brush or preferably leave it to soak overnight in a mild proprietary descaler. Ensure all traces of scale are removed and thoroughly rinse in clean water afterwards.

Before replacing the sprayplate, switch the power back on at the isolating switch and direct the hose and sprayhead to waste.

Select the COLD setting and turn the temperature control fully anti-clockwise.

Press the start/stop button.

This operation will flush out any loose scale deposits in the unit. Stop after approximately thirty seconds.

Refit the sprayplate by screwing in clockwise. Use the tool to screw in the sprayplate tight.

WARNING

DO NOT use 'powerful' abrasive or solvent cleaning fluids when cleaning the shower

CLEANING THE FILTER

The inlet filter is situated inside the solenoid inlet (fig.29).

To gain access to the filter will require the cover to be removed and disconnection and removal of the compression fitting. Also, depending on the incoming pipework arrangements, if there is not enough slack in the pipework, it could mean the removal of the unit from the wall.

When cleaning the filter, **do not** use a sharp object, as it will cause damage. It is preferable to use an old toothbrush or similar.

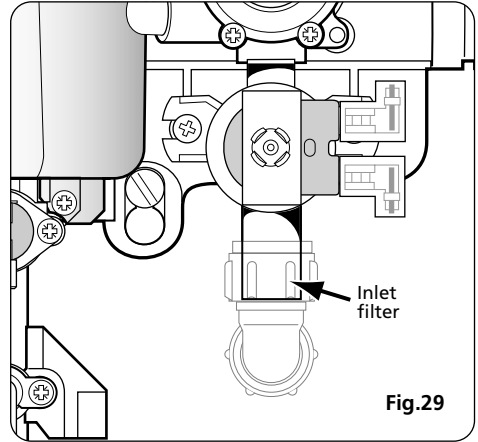
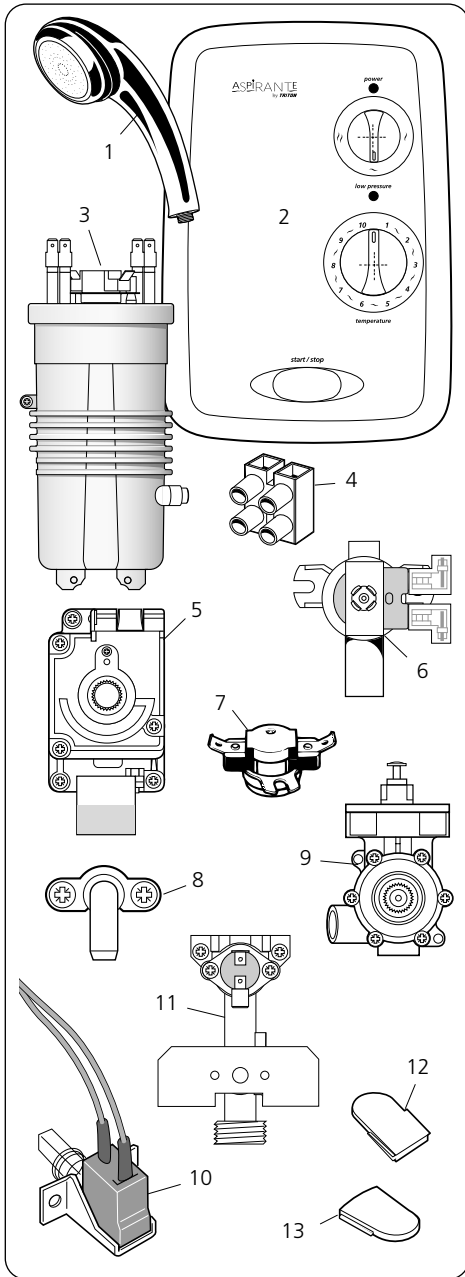

Fig.29

SPARE PARTS



Ref.	Description	Part No.
1	4 mode sprayhead	
	chrome	22420120
	gold	22420130
2	Cover assembly	
	c/w knobs & button	
	chrome	84900050
	gold	84900060
	chrome/gold	84900070
3	Can assembly 8.5kW	84500460
	Can assembly 9.5kW	84500470
	Can assembly 10.5kW	84500530
4	Terminal block	22009230
5	Switching module assembly	
	c/w actuator & m'switches	
	8.5kW & 9.5kW model	82500210
	10.5kW model	82500230
6	Solenoid valve assembly	83300450
7	Thermal cut-out (main)	22009860
8	Pressure Relief Device	82800450
9	Stabiliser valve assembly	82600550
10	Start/stop switch assembly	83305380
11	Outlet pipe assembly	
	c/w wires & PRD	
		82200590
12	Insert trim - cover	
	chrome	7052680
	gold	7052694
13	Insert trim - backplate	
	chrome	7052679
	gold	7052695
-	Power neon	82300980
-	Terminal block live wire assy.	82301000

Temperature / flow rate graph (0° C ambient)

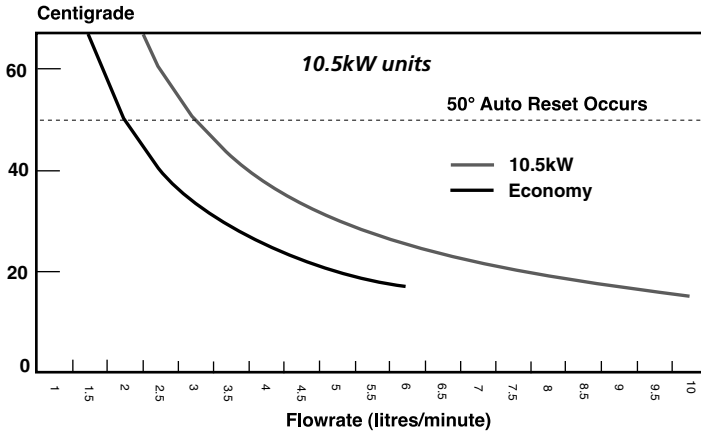
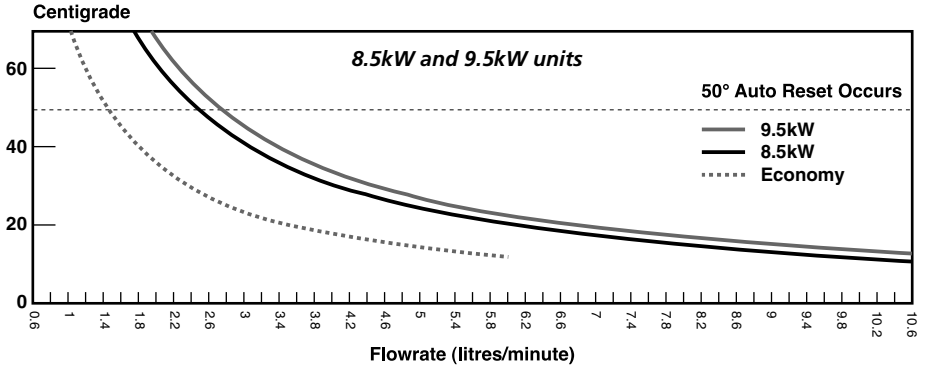

FAULT FINDING

IMPORTANT: Switch OFF the electricity at the mains supply and remove the circuit fuse before removing the cover from the shower while attempting any fault finding inside the unit.

Problem/Symptom	Cause	Action/cure
1 Shower inoperable, no water flow.	1.1 Interrupted power supply.	1.1.1 Blown fuse or circuit breaker. Check supply. Renew or reset fuse or circuit breaker. If it fails again, consult a qualified electrician. 1.1.2 Power cut. Check other appliances and if necessary, contact local Electricity Supply Co.
	1.2 Unit malfunction.	1.2.1 Have unit checked. Ring Customer Service.
2 Water too hot.	2.1 Not enough water flowing through the shower.	2.1.1 Increase flow rate via temperature control. 2.1.2 Blocked sprayhead - clean or replace blocked sprayplate in sprayhead.
	2.2 Blockage in supply.	2.2.1 Check if stop valves are fully open. Check if blockage in inlet filter.
	2.3 Increase in ambient water temperature.	2.3.1 Re-adjust flow rate to give increased flow. 2.3.2 Select 'economy' power.
3 Water temperature cycling hot/cool at intervals.	3.1 Heater cycling on outlet thermal cut- out.	3.1.1 See ' <i>Water too hot</i> ' causes 2.1, 2.2 and 2.3 and their appropriate action/cures. If it continues, contact Triton Customer Service.
4 Water too cool or cold.	4.1 Too much flow.	4.1.1 Reduce flow rate via temperature control.
	4.2 Water pressure below minimum required (see rating label).	4.2.1 Is water supply mains or tank fed ?
		4.2.2 If tank fed, re-plumb to mains water supply or see 4.2.4.
		4.2.3 If mains fed, ensure that mains stopvalve is fully open and that there are no other restrictions in the supply while shower is in use, or see 4.2.4.
4.2.4 Fit pump to give minimum pressure (see rating label). Contact Customer Service for advice.		
4.3 Reduction in ambient water temperature.	4.3.1 Re-adjust flow rate to give reduced flow. 4.3.2 Select 'high' power.	
4.4 Electrical malfunction or safety cut-out operated.	4.4.1 Have unit checked by suitably qualified electrician or contact Triton Customer Service	
5 Shower varies from normal temperature to cold during use.	5.1 Water pressure has dropped below minimum required.	5.1.1 Wait until the water pressure resumes to normal.

FAULT FINDING (continued)

<i>Problem/Symptom</i>	<i>Cause</i>	<i>Action/cure</i>
6 Pressure relief device has operated (water ejected from PRD tube).	6.1 Blocked sprayhead.	6.1.1 Clean or replace blocked sprayplate in sprayhead and then fit new PRD.
	6.2 Twisted/blocked flexible shower hose.	6.2.1 Check for free passage through hose. Replace the hose if necessary and fit new PRD.
	6.3 Sprayhead not removed whilst commissioning.	6.3.1 Fit new PRD. Commission unit with sprayhead removed.

Note: Identify cause of operation before fitting new PRD unit. When fitting a new PRD, follow the commissioning procedure.

It is advised all electrical maintenance/repairs to the shower should be carried out by a suitably qualified person.



A **MORGROS** Company

TRITON STANDARD GUARANTEE

Triton Plc guarantee this product against all mechanical and electrical defects arising from faulty workmanship or materials for a period of two years for domestic use only, from the date of purchase, provided that it has been installed by a competent person in full accordance with the fitting instructions.

Any part found to be defective during this guarantee period we undertake to repair or replace at our option without charge so long as it has been properly maintained and operated in accordance with the operating instructions, and has not been subject to misuse or damage.

This product must not be taken apart, modified or repaired except by a person authorised by Triton Plc. This guarantee applies only to products installed within the United Kingdom and does not apply to products used commercially.

This guarantee does not affect your statutory rights.

What is not covered:

1 Breakdown due to: **a)** use other than domestic use by you or your resident family; **b)** wilful act or

neglect; **c)** any malfunction resulting from the incorrect use or quality of electricity, gas or water or incorrect setting of controls; **d)** faulty installation.

2 Repair costs for damage caused by foreign objects or substances.

3 Total loss of the product due to non-availability of parts.

4 Compensation for loss of use of the product or consequential loss of any kind.

5 Call out charges where no fault has been found with the appliance.

6 The cost of repair or replacement of pressure relief devices, sprayheads, hoses, riser rails and/or wall brackets, isolating switches, electrical cable, fuses and/or circuit breakers or any other accessories installed at the same time.

7 The cost of routine maintenance, adjustments, overhaul modifications or loss or damage arising therefrom, including the cost of repairing damage, breakdown, malfunction caused by corrosion, furring, pipe scaling, lime scale, system debris or frost.

Service Policy

In the event of a complaint occurring, the following procedure should be followed:

1 Telephone Customer Service on (024) 7637 2222 (08457 626591 in Scotland and in Northern Ireland), having available the model number and power rating of the product, together with the date of purchase.

2 Triton Customer Service will be able to confirm whether the fault can be rectified by either the provision of a replacement part or a site visit from a qualified Triton service engineer.

3 If a service call is required it will be booked and the date of call confirmed. In order to expedite your request, please have your postcode available when booking a service call.

4 It is essential that you or an appointed representative (who must be a person of 18 years of age or more) is present during the service engineer's visit and receipt of purchase is shown.

5 A charge will be made in the event of an aborted service call by you but not by us, or where a call under the terms of guarantee has been booked and the failure is not product related (i.e. scaling and furring, incorrect water pressure, pressure relief device operation, electrical installation faults).

6 If the product is no longer covered by the guarantee, a charge will be made for the site visit and for any parts supplied.

7 Service charges are based on the account being settled when work is complete, the engineer will then request payment for the invoice. If this is not made to the service engineer or settled within 10 working days, an administration charge will be added.

Replacement Parts Policy

Availability: It is the policy of Triton to maintain availability of parts for the current range of products for supply after the guarantee has expired. Stocks of spare parts will be maintained for the duration of the product's manufacture and for a period of five years thereafter.

In the event of a spare part not being available a substitute part will be supplied.

Payment: The following payment methods can be used to obtain spare parts:

1 By post, pre-payment of pro forma invoice by cheque or money order.

2 By telephone, quoting credit card (MasterCard or Visa) details.

3 By website order, www.tritonshowers.co.uk

Triton Plc, Shepperton Park, Caldwell Road,
Nuneaton, Warwickshire. CV11 4NR

Customer Service

☎ (024) 7637 2222

Scottish and Northern Ireland Customer Service

☎ 08457 626591

Trade Installer Hotline

☎ (024) 7632 5491

Fax: (024) 7632 4564

www.tritonshowers.co.uk

E mail: technical@triton.plc.uk