

TRITON

**AS2000X
Power Shower**



**Installation and
operating
instructions**

INSTALLERS PLEASE NOTE THESE INSTRUCTIONS ARE TO BE LEFT WITH THE USER

CONTENTS	Page
Plumbing and electrical notes	1
Introduction	2
Safety warnings	2
Key to main components	3
Specifications	3
Site requirements	4 – 5
General installation notes	5
Siting of the shower	6
Removing the cover	7
Plumbing connections	7 – 9
Fitting the shower to the wall	10
Electrical connections	11
Commissioning	12 – 14
Fitting the riser rail	15 – 16
Operating the shower	17 – 18
Adjusting the maximum temperature stop	18
Adjusting the sprayhead	19
Cleaning	20
Cleaning the filters	21
Spare parts	22 – 23
Fault finding	24 – 25
Guarantee, service policy, etc.	rear cover

To ensure the product suitability for commercial and multiple installations, please contact Triton's specification advisory service prior to installation.

Telephone: (024) 7632 5491

Facsimile: (024) 7632 4564

E mail: technical@triton.plc.uk

1 PLUMBING NOTES

- 1.1** All installations must comply with the Water Regulations or Byelaws.
- 1.2** Supply pipes must be flushed to clear debris before connecting the shower unit.
- 1.3** DO NOT connect the shower unit to the mains cold water supply as it will damage the unit and also be in breach of Water Regulations.
- 1.4** DO NOT use excessive force when making connections to the flexible hose or sprayhead – finger tight is sufficient.
- 1.5** ALL plumbing connections are to be completed and water supplies turned on BEFORE switching on the electricity supply. The shower must not be operated dry without water.
- 1.6** DO NOT solder pipes or fittings within 300mm of the shower appliance, as heat transfer can damage components.
- 1.7** When installed, the top of the shower unit must be at least 75mm lower than the base of the cold water storage cistern to prevent the pump being run dry without water.
- 1.8** A dedicated cold water supply must be taken directly from the cold water cistern to the shower. This draw-off must be on the opposite side of the cistern to the float operated valve to reduce the risk of air entering the unit.
- 1.9** The action of the pump is to increase the flow rate. If the supply pipework cannot handle the resulting flow rate then:
 - 1.9.1** The anticipated flow rate may not be achieved.
 - 1.9.2** Air may be drawn into the hot supply from the vent pipe causing spluttering and temperature fluctuations at the sprayhead.

- 1.10** Fullway isolating valves or fullway lever valves MUST be fitted on the hot and cold water supplies to the shower as an independent means of isolating the water supplies should maintenance or servicing be necessary. DO NOT use stop taps or ball-o-fix type valves which restrict flow.

2 ELECTRICAL NOTES

- 2.1** The installation must comply with BS 7671 'Requirements for electrical installations' (IEE wiring regulations). Make sure the incoming hot and cold water supplies to the shower are adequately earth bonded.
- 2.2** DO NOT turn on the electrical supply until the plumbing connections have been completed. Only then can the electricity be switched on in order to power the solenoid to turn water on to the shower when commissioning. The shower must not be operated dry without water.
- 2.3** The mains supply must be 230/240V, at 50Hz, connected to the unit via a double pole switched 3 Amp fused connection unit (not supplied) with a minimum 3mm contact separation gap in each pole.
- 2.4** In accordance with 'The Plugs and Sockets etc. (Safety) Regulations 1994', this unit is intended to be permanently connected to the fixed electrical wiring of the mains system.
- 2.5** Fuses do not give personal protection against electric shock.
- 2.6** It is strongly recommended to fit a 30mA residual current device (RCD). This may be part of the consumer unit or a separate unit.

INTRODUCTION

This book contains all the necessary fitting and operating instructions for your Triton power shower.

Take time to read this book thoroughly and familiarise yourself with all instructions BEFORE beginning installation. Please keep it for future reference.

The shower installation must be carried out by a suitably competent person and in the sequence of this instruction book.

Care taken during the installation will ensure a long and trouble-free life from your shower

IMPORTANT: All plumbing connections must be completed BEFORE making the electrical connections.

IMPORTANT: The fittings on the pipe inlet elbows are of the push-in type. The pipework must be cut with a pipe cutter and all burrs and rough edges removed from the end of the tube. The fittings can be used with copper and plastic pipe.

Where chrome plated pipe is used, remove the first 25mm of plating.

Note : The pump inside this product is rated 15 minutes on / 45 minutes off duty cycle.

Replacement parts can be ordered from Triton Customer Service. See 'spare parts' for details and part numbers.

Due to continuous improvement and updating, specification may be altered without prior notice.

SAFETY WARNINGS

WARNING!

The power shower does not contain a thermostatic valve – it will not shut off in the event of failure of either the hot or cold water supplies.

- a. DO NOT insert fingers into the push-in inlet fittings. Doing so could cause injury.
- b. **Under no circumstances must this product be connected to mains cold or hot water supplies.** Failure to comply will invalidate the guarantee.
- c. The shower MUST NOT be used if suspected of being frozen.
- d. The outlet of this appliance must not be connected to any form of tap or fitting not recommended by the manufacturer.
- e. The sprayhead cartridge must be cleaned regularly to remove scale and debris.
- f. This appliance must be earthed.
- g. Switch off immediately at the isolating switch if water ceases to flow during use. Contact Customer Service for advice.
- h. If it is intended to operate the shower outside the guidelines laid out in site requirements, contact Customer Service for advice.

In the interest of electrical safety a 30mA residual current device (RCD) should be installed in all UK 230V electric and pumped shower circuits. This may be part of the consumer unit or a separate unit.

KEY TO MAIN COMPONENTS

- 1** Top pipe entry and cable entry
- 2** Terminal block
- 3** Cover screw fixing
- 4** Motor cover
- 5** Rear pipe entry and cable entry
- 6** Wall fixing holes
- 7** Pipe inlet elbow - top (contains single check valves)
- 8** Filter cover - top
- 9** Pump
- 10** Printed Circuit Board housing
- 11** Temperature control valve
- 12** Valve spindle
- 13** Solenoid
- 14** Filter cover - bottom
- 15** Pipe inlet elbow - bottom (contains single check valves)
- 16** Outlet
- 17** Bottom pipe entry
- 18** Potentiometer control

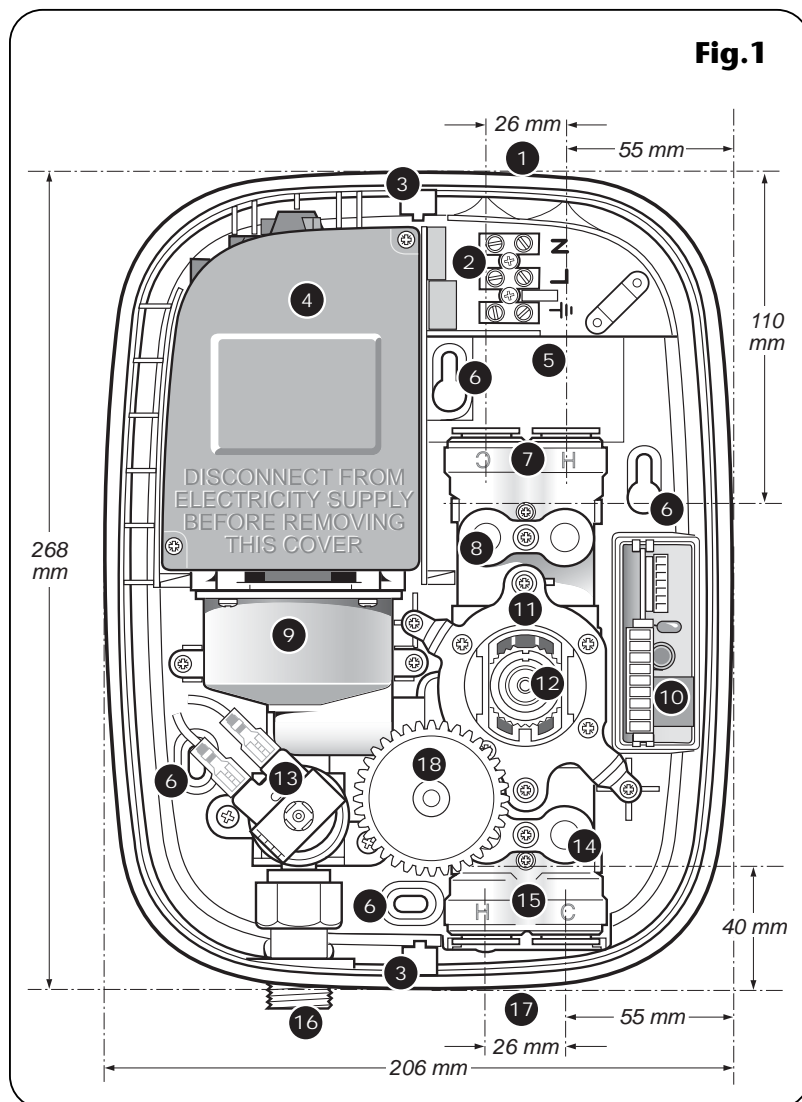

SPECIFICATIONS

Hot water temperature

Maximum temperature 65°C.

BS 6700 recommends that the temperature of stored water should never exceed 65°C. A stored water temperature of 60°C is considered sufficient to meet all normal requirements and will minimise the effects of scale in hard water areas.

Maximum static inlet pressures

1 bar or 10m (supplies must be gravity fed at nominally equal pressures).

Minimum static inlet pressure

0.0075 bar or 75mm (required to prime the integral centrifugal pump).

SITE REQUIREMENTS

Water

The installation must be in accordance with Water Regulations/Byelaws and BS 6700.

For correct operation of this shower unit, both hot and cold water supplies to the appliance must be gravity fed, at nominally equal pressures, from a cold water storage cistern and a hot water storage cylinder.

The water circuit should be installed so that the flow is not significantly affected by other taps and appliances being operated elsewhere on the premises.

Fig.2 shows a recommended installation where the hot water supply for the shower is made via a tee connection on the underside of the horizontal section of pipework from the cylinder. Alternatively, the connection can be taken from the hot supply pipe to other outlets as long as it

is the first draw-off below the ventilation pipe tee.

Fig.3 illustrates all the incorrect connections that must be avoided.

All pipework to the shower unit must be routed where it remains below the level of water in the cistern. In the case of horizontal sections of pipework in lofts, it may be necessary to fit automatic air vents at high points on the supplies to remove the possibility of air locks.

For the operation of the shower only, it is recommended that the cold water storage cistern is capable of holding at least 114 litres (25 gallons). Where other hot and cold outlets are likely to be in use simultaneously, the storage capacity should be increased to 228 litres (50 gallons) in accordance with BS 6700.

Do ensure compliance with the Water Regulations/Byelaws.

DO NOT connect to a combination cylinder

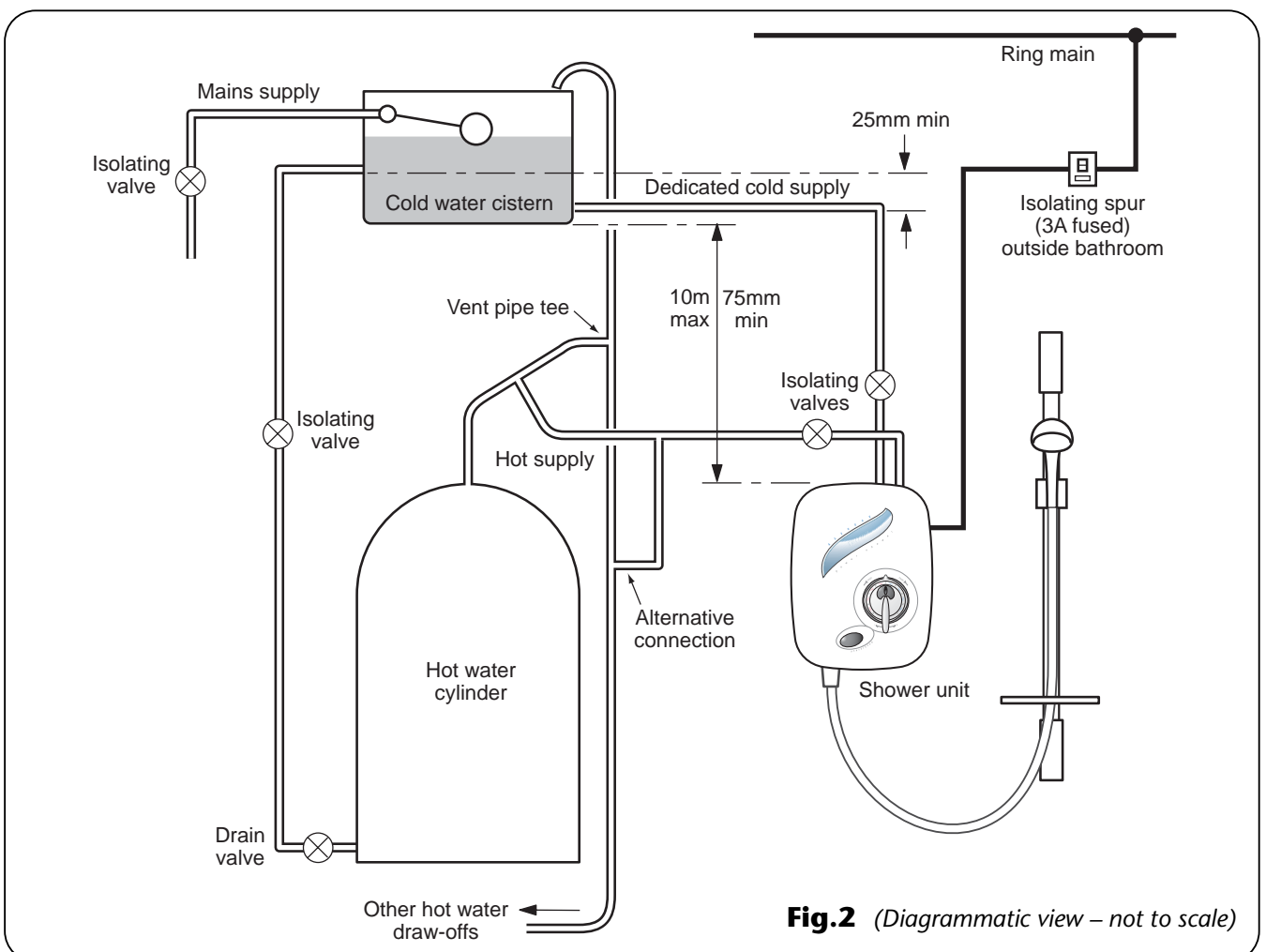

Fig.2 (Diagrammatic view – not to scale)

unless there is a guaranteed 114 litre cold supply to the cylinder as the shower can deliver up to 14 litres per minute. It is advisable to check that the infill rate from the float operated valve meets the output requirements.

It is recommended that there is a minimum of approximately 114 litres (25 gallons) of hot water storage per appliance.

The shower MUST NOT be connected to the mains cold water supply.

DO NOT use jointing compounds.

GENERAL INSTALLATION NOTES

- 1 DO NOT take risks with plumbing or electrical equipment.
- 2 DO NOT install this unit in a position where it could become frozen.
- 3 Isolate electrical and water supplies BEFORE proceeding with installation work.

- 4 Shower control MUST be fed from a cold water storage cistern and hot water cylinder that provides nominally equal pressures.
- 5 The unit must be mounted onto the finished wall surface (on top of tiles).
DO NOT tile up to the unit after fixing to the wall.
- 6 If installing with rear inlet supplies, it is recommended the supply pipework is sealed to the wall so as to prevent water from leaking back into the wall.
- 7 In solid wall installations, the supply pipework should be housed within ducting in order to allow some free lateral movement when making connections and to ensure compliance with requirements of accessibility of pipes and pipe fittings.

Fig.4 shows a schematic wiring diagram of the unit.

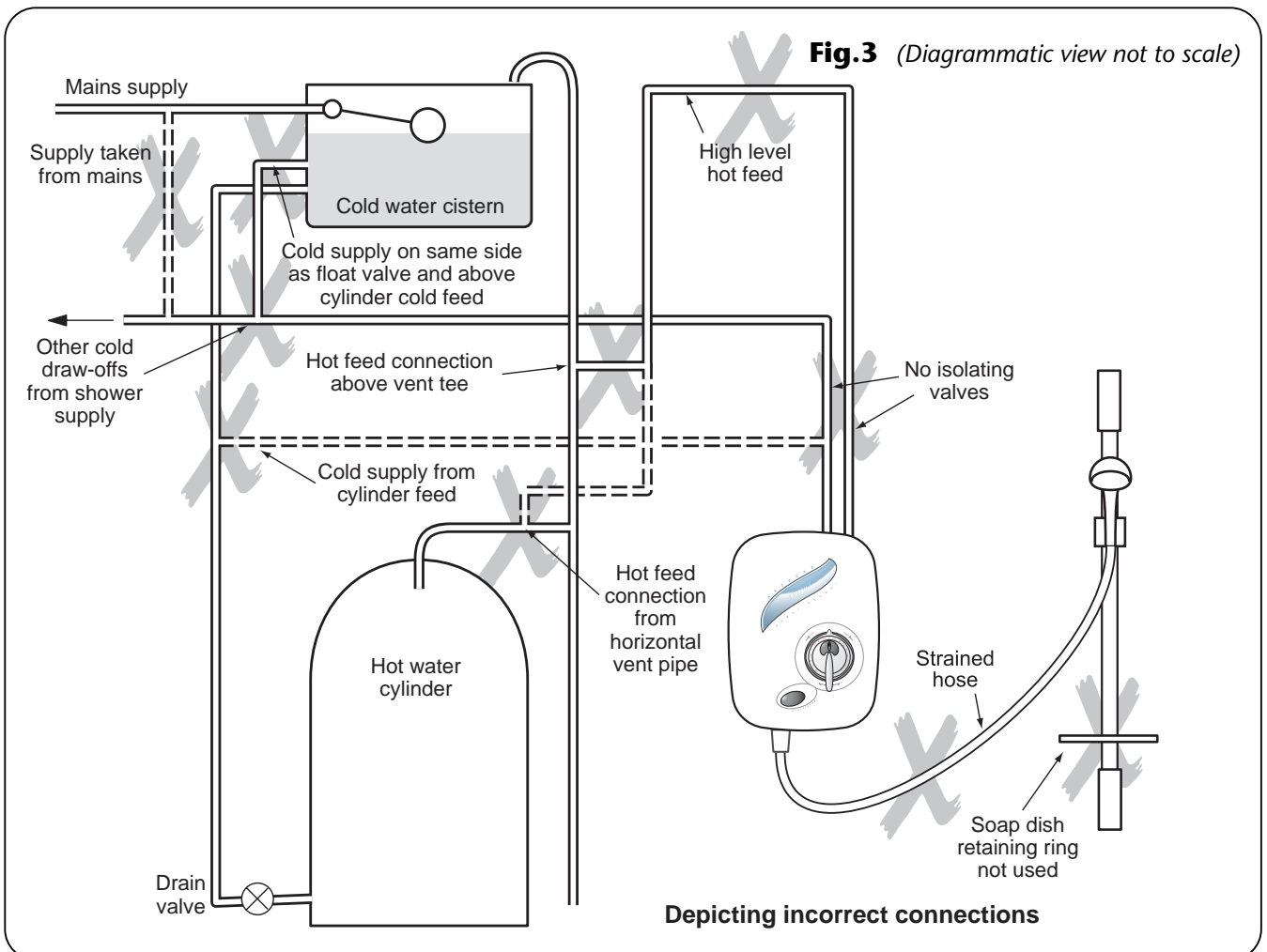
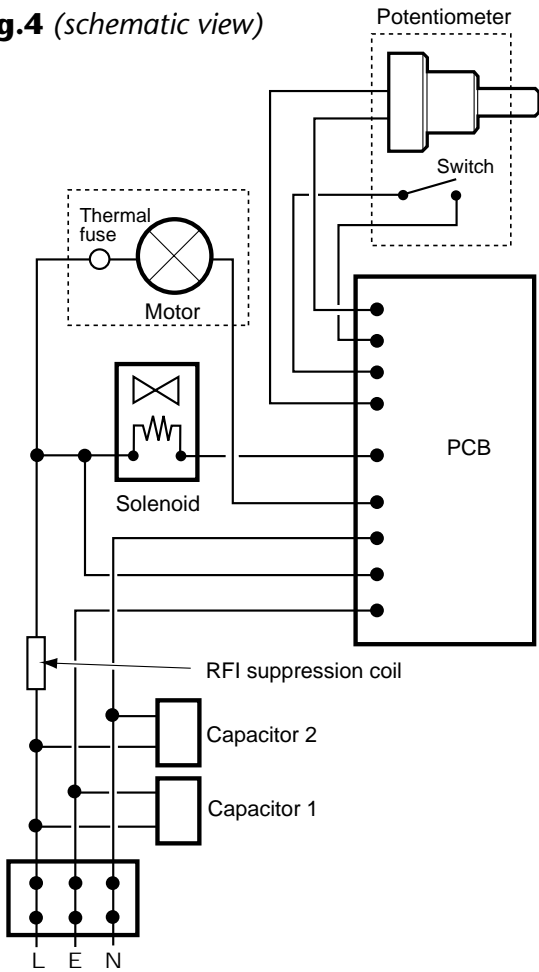

Fig.4 (schematic view)



SITING OF THE SHOWER

WARNING!

The shower must not be positioned where it will be subject to freezing conditions.

IMPORTANT: If mounting onto a tiled wall always mount the unit on the surface of the tiles. NEVER tile up to the unit.

Refer to **fig.5** for correct siting of the shower. Position the unit vertically where it will NOT be in direct contact with water from the sprayhead.

Note: Allow sufficient room between the ceiling and the shower unit to access the top cover screw.

Position the shower and sprayhead on the wall so that all controls can be comfortably reached when using the shower.

The sprayhead and riser rail can be positioned either side of the shower unit.

Note: Water Regulations require the sprayhead be 'constrained by a fixed or sliding attachment so that it can only discharge water at a point not less than 25mm above the spill-over level of the relevant bath, shower tray or other fixed appliance'. The use of the supplied soap dish will in most cases meet this requirement, but if the sprayhead can be placed within a bath, basin or shower tray, then a device must be fitted to prevent back-flow.

Fig.5

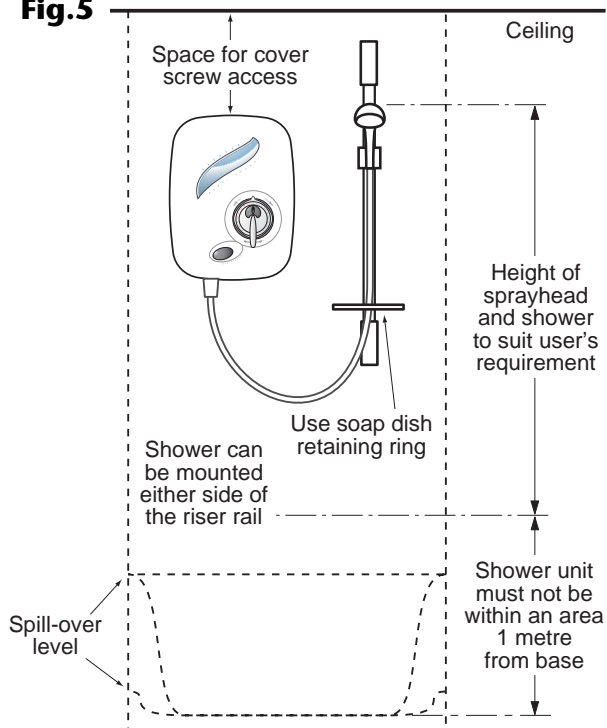

REMOVING THE COVER

To remove the cover, first pull off the cover trim (**fig.6**) to reveal the retaining screw.

Undo the screw and pull off the inner temperature control. Now remove the outer flow control assembly comprising of the flow control, maximum temperature stop and temperature disc (**fig.7**).

Note: If adjustment of the maximum temperature stop is required, refer to section 'Adjusting the maximum temperature stop'.

Remove the two cover fixing screws – top and bottom (**fig.8**).

Carefully lift the cover away from the backplate. Lay aside the cover and screws until the unit is fully installed.

Note: When removing the cover for future maintenance purposes be aware of the lead connecting the Start/Stop switch to the PCB harness. To release, squeeze the connection block arms and pull apart. DO NOT let the unit dangle by the lead.

PLUMBING CONNECTIONS

Plumbing to be carried out before wiring

Note: The outlet of the shower must not be connected to any tap or fitting not recommended by Triton Plc.

DO NOT use jointing compounds on any pipe fittings for the installation.

When connecting pipework avoid using tight 90° elbows. Swept or formed bends will give optimum performance.

Isolate the mains water supply to the cold water cistern. Drain the hot and cold pipes by opening all taps.

The hot water supply can be taken from the hot supply pipe from the cylinder, making sure that it is the first draw-off below the ventilation pipe tee in order to minimise the effects of water draw-off elsewhere in the house (**see fig.2**).

Note: There must not be any other draw-offs between the take-off point and the shower.

A dedicated cold water supply must be taken directly from the cold water cistern to the shower. This draw-off must be positioned 25mm

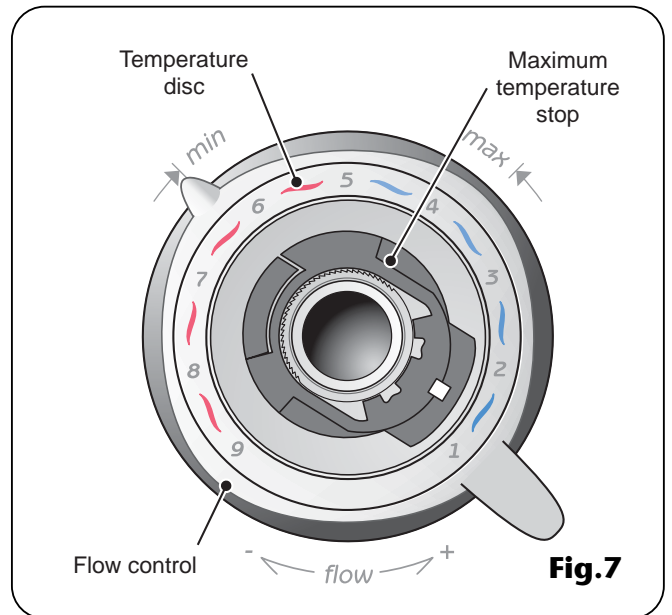

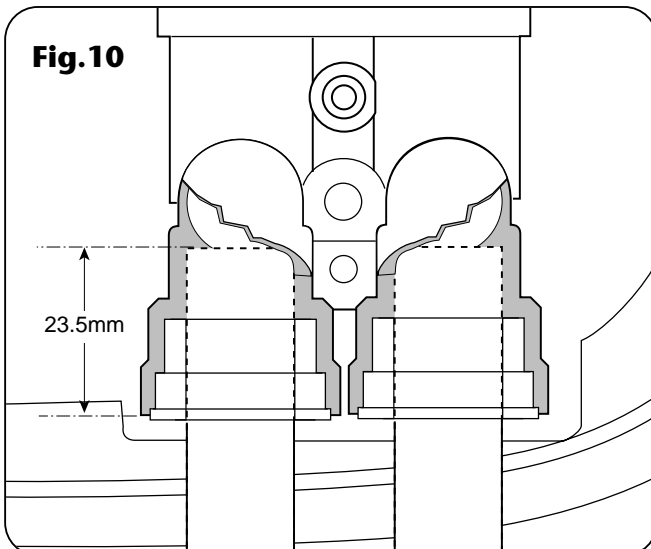
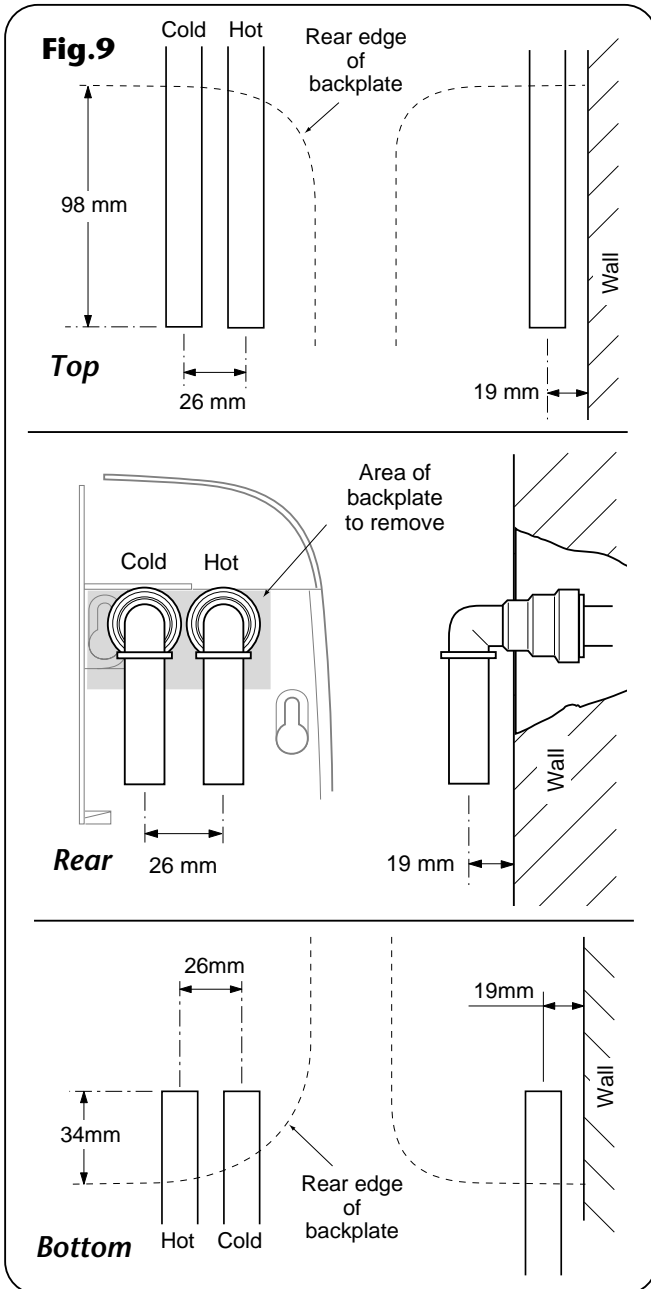

below the cold feed connection to the hot water cylinder on the opposite side of the cistern to the float operated valve (**see fig.2**). This minimises air ingress into the pipework.

Plumbing options other than those outlined in these fitting instructions could impair the performance. For example, if hot and cold connections are made after draw-off points to other outlets, (eg. washing machine, taps, etc.) it could result in unstable flows and temperatures should other appliances operate at the same time.

Run the hot and cold pipework to the shower position. Make sure that the pipework does not rise above the level of water in the cold cistern at any point to avoid air locks. Under normal site conditions 15mm pipework will be adequate.

Decide the position of the shower. Cut the pipework to the dimensions relevant to the chosen direction of water entry into the shower.

IMPORTANT: For rear entry only, the supplied elbows must be used. For ease of installation, the backplate area adjacent to the top pipe inlet must be cut out, including the top left wall fixing hole. When fitting the elbows to incoming pipework, make sure the elbow collets are fully engaged with the pipe.

Dimensions are shown in **fig.9** and **fig.10**.

Note: The pipe inlets are marked for hot and cold connections – left-hand side for hot inlet on bottom entry (**fig.11**), but right-hand side for hot inlet on top or rear entry (**fig.12**).

IMPORTANT: The fittings on the inlet elbows are the push-in type. The pipework must be cut with a pipe cutter and all burrs and rough edges removed from the end of the tube. The fittings can be used with copper and plastic pipe.

If using chrome plated copper pipe, remove the first 25mm of plating completely from the connecting surfaces. If not completely removed then the collet will not grip the pipe and under pressure the pipe may be forced out.

Note: Pipework must be clipped or fixed to the wall so that it cannot be moved or removed without the aid of a tool.

Note: The pipe inlets contain filters. These should be periodically removed and cleaned in order to maintain the performance of the shower. See section 'cleaning' on how to access the filters.

IMPORTANT: The inlets contain check valves, so before completing the connection of the water supplies to the shower flush out the pipework to remove all swarf and system debris that may cause damage to internal parts. This can be achieved by connecting a hose to the pipework and turning on the water supplies long enough to clear the debris to waste.

IMPORTANT: Two factory fitted blanking plugs are fitted to the top pipe inlets. These should be left in position if bottom pipe entry is required.

For top or rear pipe entry, the two plugs **MUST** be removed and refitted into the bottom pipe inlets. Failure to fit the blanking plugs will result in the unit working erratically.

Insert the pipe removal tool supplied between the flange of the plug and the grey collet and lever the plug outward (**fig.13**). Whilst holding back on the collet, pull out each plug by hand. When refitting the plugs in the bottom pipe inlets, make sure they are pushed fully home.

Note: The unit is supplied with a splash guard (**fig.14**) to prevent water ingress when top entry pipework is used. If fitting top entry pipework, make sure the splash guard is correctly fitted (**fig.14**) before replacing the cover.

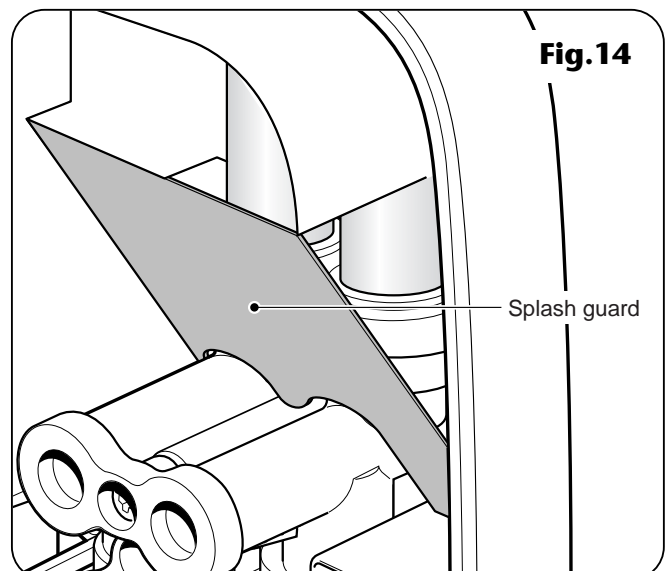
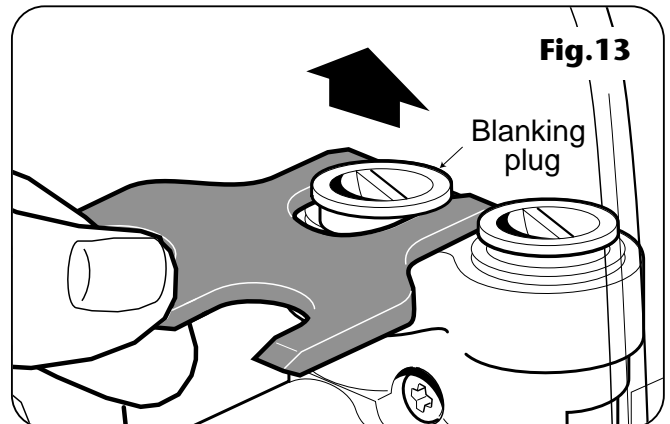
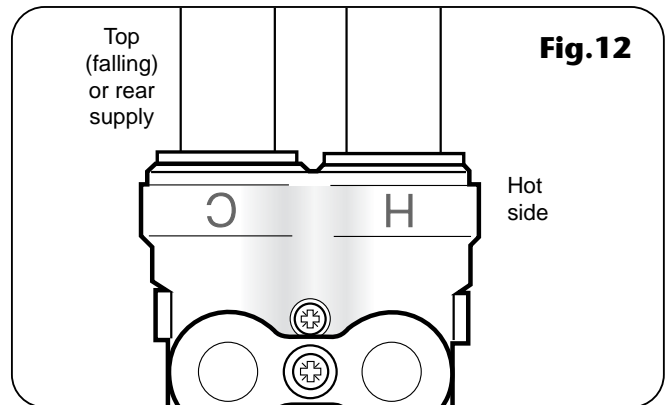
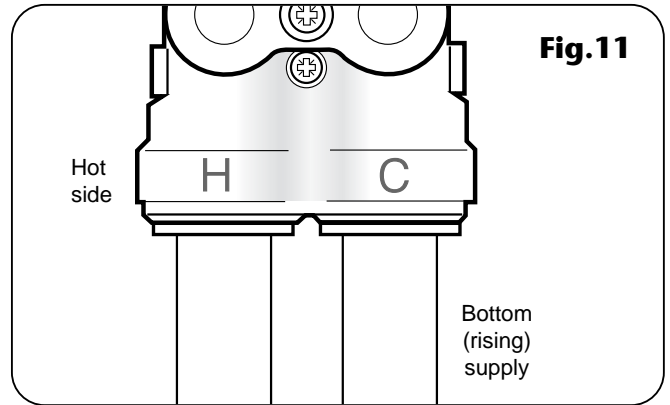

FITTING THE SHOWER TO THE WALL

IMPORTANT: Prior to fitting the shower make sure the plumbing is flushed out, removing all debris, flux etc.

For top pipe entry or top cable entry remove the relevant cut-outs by either breaking out or by using a knife or junior hacksaw (**fig.15**).

If top entry for both pipe and cable is required, then additionally remove the shaded area (**fig.15**) by using a knife or junior hacksaw.

For bottom pipe entry remove the cut-out and break off the two circular parts (**fig.16**). Replace the cut-out.

For rear pipe entry only, the supplied elbows must be used with the necessary portion of backplate cut away as shown in **fig.9**.

It will be necessary if rear cable entry is required, for conduit or other routing of the electrical cable to be completed before fixing the shower to the wall.

Offer the backplate unit up to the completed pipework and manoeuvre so that the end of the pipes enter fully into the inlet fittings.

Mark positions for wall fixing holes using backplate as template (**fig.17**). Note that four fixing holes are provided but using only two should be adequate for most site conditions.

Using the pipe removal tool supplied, push back and hold the collects from the pipework (**fig.18**) in order to disengage pipework from the inlet elbows.

Remove unit from the wall.

Drill and plug the fixing holes. (*The wallplugs provided are suitable for most brick walls – use an appropriate masonry drill, but if the wall is plasterboard or a soft building block, use special wallplugs and an appropriate drill bit*).

Note: If fitting rising supplies to the unit, make sure debris does not enter the pipes when drilling the wall.

Offer the backplate unit up to the completed pipework and manoeuvre so that the end of the pipes enter fully into the inlet fittings.

Check the backplate is square and the fixing holes are aligned (**fig.17**). Secure to the wall with fixing screws supplied.

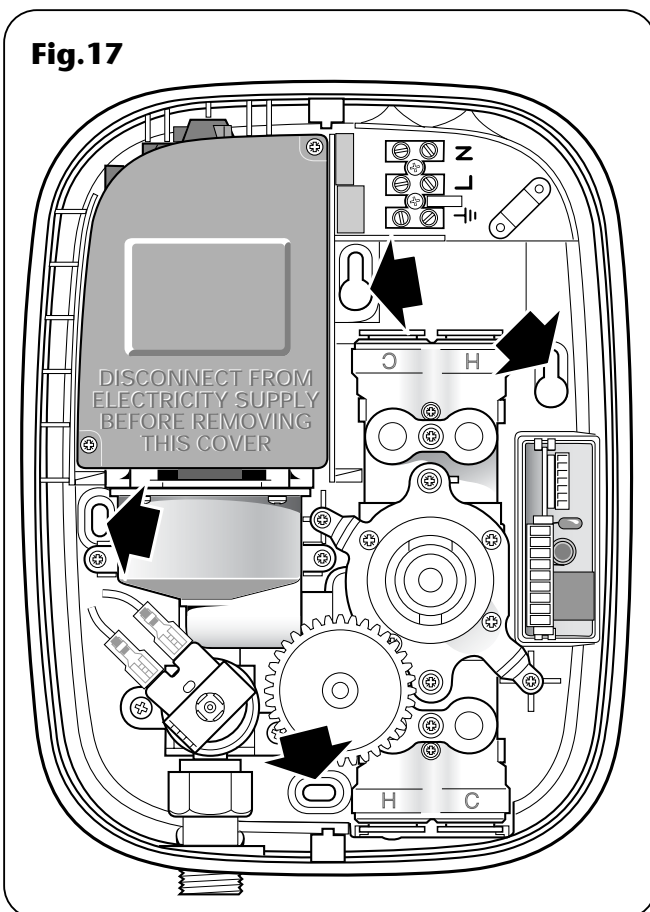
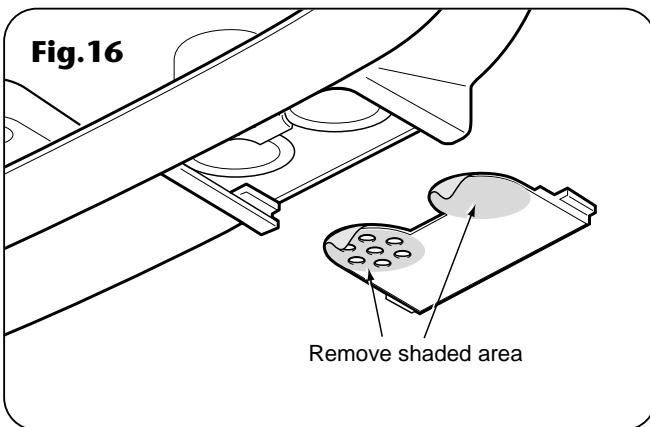
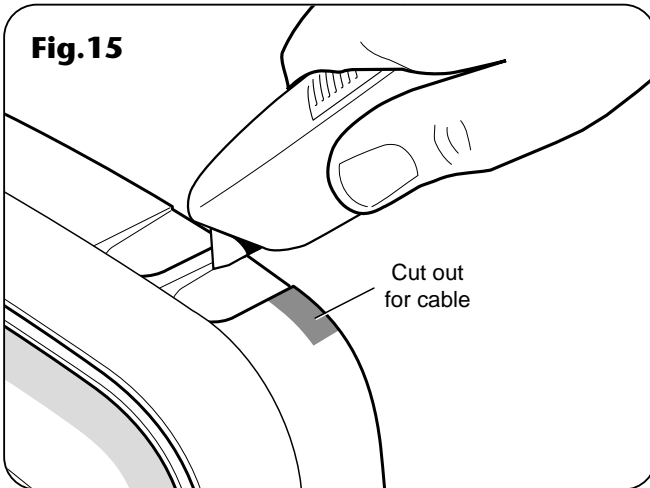

ELECTRICAL CONNECTIONS

WARNING!

This unit must be earthed. Isolate the electrical supply before starting.

The supply cable must conform to relevant tables in current IEE regulations. In most cases 1mm² twin and earth will be adequate.

The electrical rating of the shower is on the rating label within the unit.

SWITCH OFF THE ELECTRICITY SUPPLY AT THE MAINS.

Cable entry points are shown in **fig.1**. Conduit entry can only be from the rear. Route the cable into the shower, taking care to avoid the area of the wall fixings and connect to the terminal block (**fig.19**) as follows:

Earth cable to terminal marked **E** ⊕

Neutral cable to terminal marked **N**

Live cable to terminal marked **L**

IMPORTANT: Fully tighten the terminal block screws and check that no cable insulation is trapped under the screws.

Note: The supply cable earth conductor must be sleeved.

The earth continuity conductor of the electrical installation must be effectively connected electrically to all exposed metal parts of other appliances and services in the room in which the shower is to be installed, to conform to current IEE regulations.

Note: Fuses do not ensure user protection against electric shock. In the interest of electrical safety, all mains electric and pumped showers should be fitted with a 30mA residual current device (RCD). This may be part of the consumer unit or a separate unit.

DO NOT switch on the electricity supply until the water has been turned on to the unit and connections have been tested for leaks.

IMPORTANT: The cover may be left off initially only for commissioning.

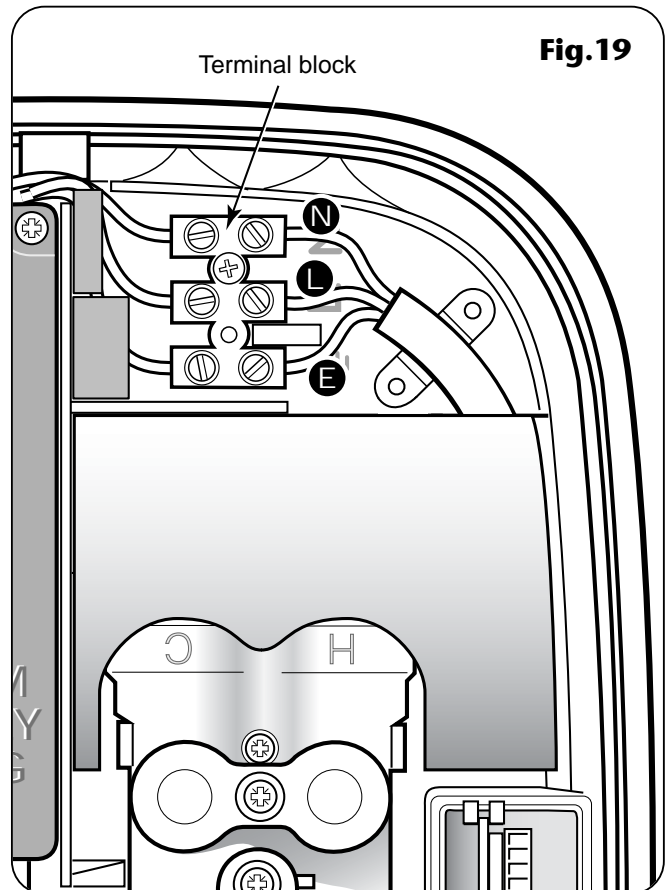
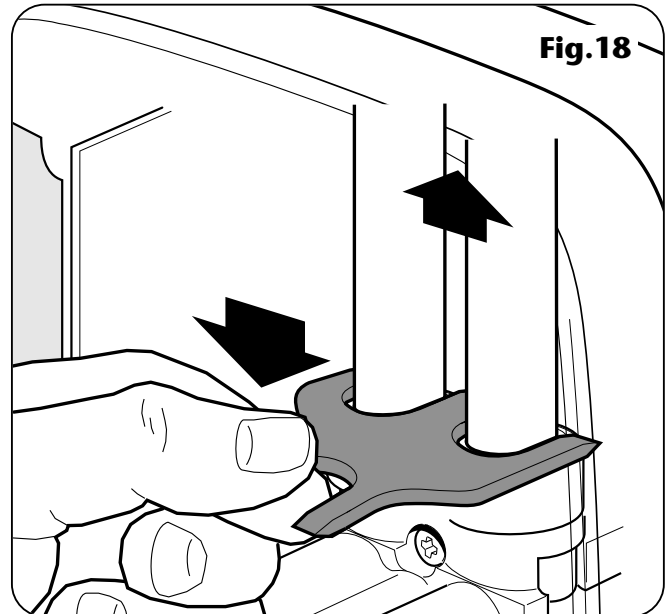

COMMISSIONING

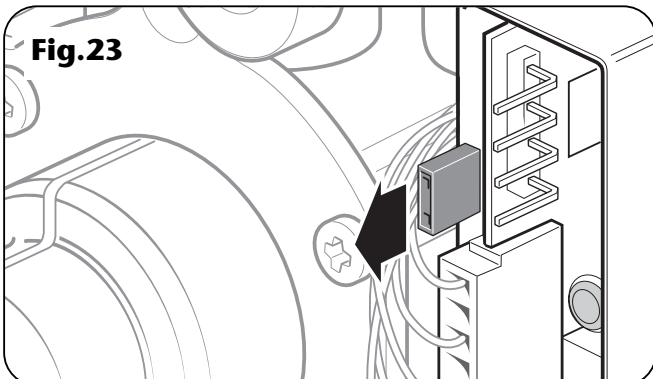
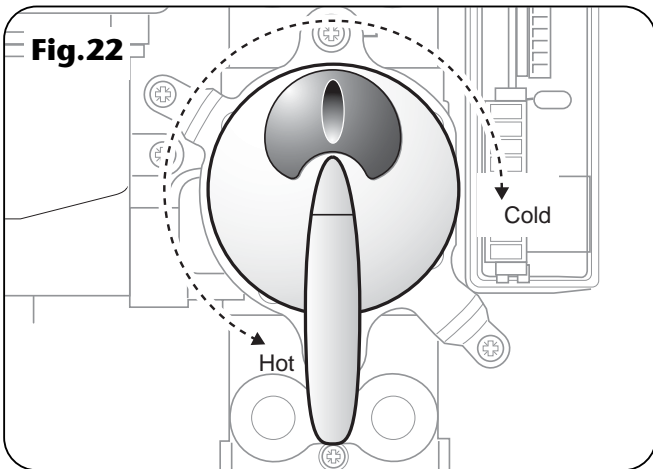
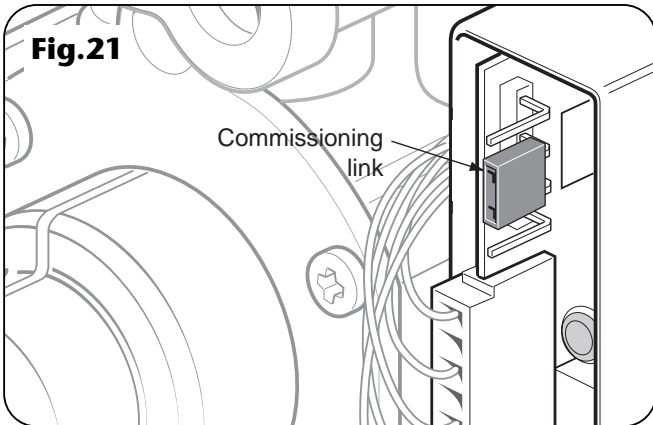
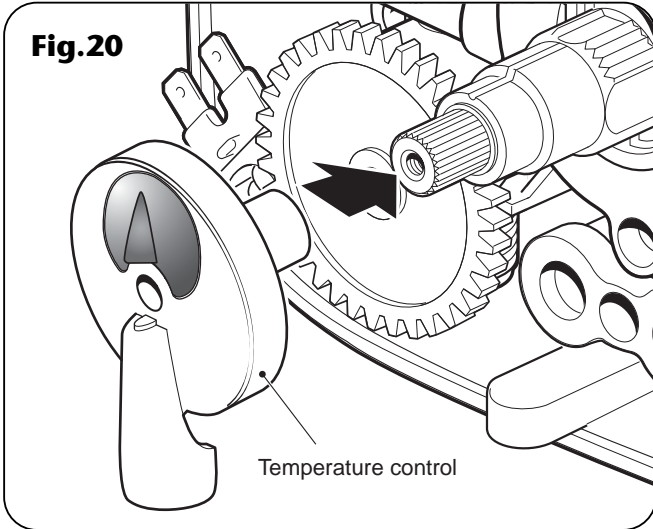

WARNING!

Before normal operation of the shower, it is essential the commissioning and setup procedure are correctly completed. Failure to do so could cause the pump to run dry without water and invalidate your guarantee.

The first operation of the shower is intended to flush out any remaining system debris and to ensure water is purged through the unit. This operation must be carried out with the flexible hose screwed to the shower outlet but without the sprayhead attached.

Make sure the outlet of the flexible hose is directed to waste.

Check the isolating valves controlling the water supply to the unit are fully open.

Note: There is no need to fit the cover at this stage but be aware of live parts when the electricity is switched on temporarily.

Fit the temperature control onto the splined spindle (**fig.20**).

On the PCB, make sure the commissioning link is positioned on the middle two pins (**fig.21**).

Switch on the electric supply at the isolating switch. Water will begin to flow under gravity pressure.

Once the unit has been commissioned, disconnect the electricity supply *before* removing the commissioning link.

WARNING!

Be aware of live parts in the unit when the electricity is switched on. DO NOT tamper with any parts and DO NOT deviate from the following instructions.

In order to dispel air and to prime both supplies to the shower unit, turn the temperature control several times within its rotational limits. ONCE

RESISTANCE IS FELT, DO NOT FORCE THE CONTROL FURTHER.

Note: The temperature control rotates less than one complete turn (**fig.22**). DO NOT force it beyond these limits.

To stop the water flow, switch off the electricity supply at the isolating switch.

Check for leaks in the pipework and remedy if necessary. If rear entry has been used then seal around pipes with mastic to prevent the possibility of water entering the wall cavity.

DO NOT use plaster as this could cause difficulty if maintenance is required later.

Setup procedure

MAKE SURE THE ELECTRICITY TO THE UNIT IS SWITCHED OFF.

WARNING!

Once the unit has been commissioned, turn off the electricity supply at the mains before removing the commissioning link.

Pull off the temperature control. Remove the commissioning link from the PCB (**fig.23**) and store safely for future use.

Inside the cover, attached to the flow control potentiometer is a 4-wire lead. Fit the connector on the end of this lead to the 4 pins on the PCB (**fig.24**) – it can fit either way.

Make sure the potentiometer control is rotated fully anti-clockwise (**fig.25**).

Replacing the cover

Offer the cover to the backplate unit. Inside the cover, attached to the stop/start switch is a two wire lead. The socket on the end of this lead must connect to the plug attached to the backplate unit (**fig.26**).

Fit the cover, making sure the connector is fitted to the PCB and the wires are clear of obstructions. Secure with the top and bottom fixing screws (**fig.8**).

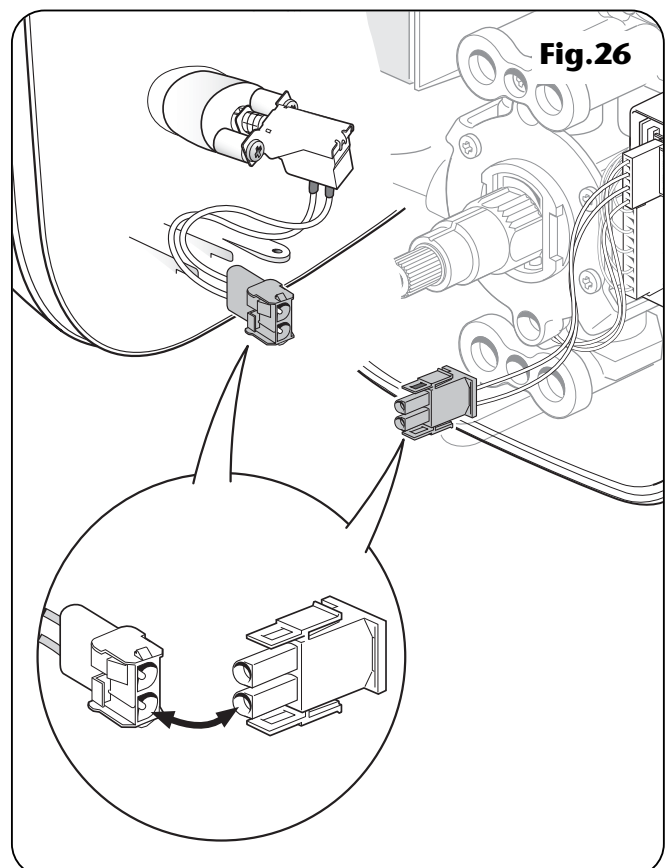
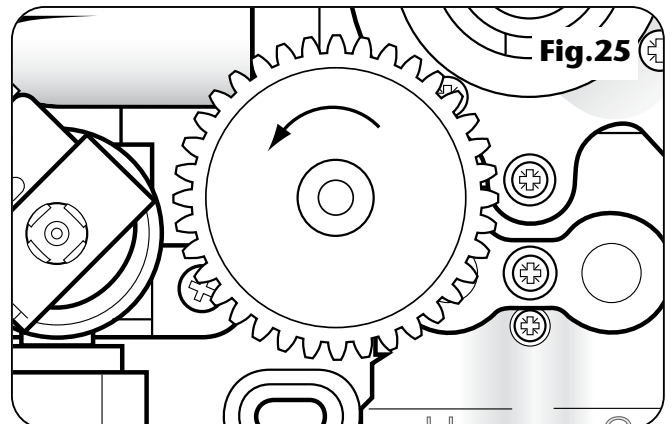
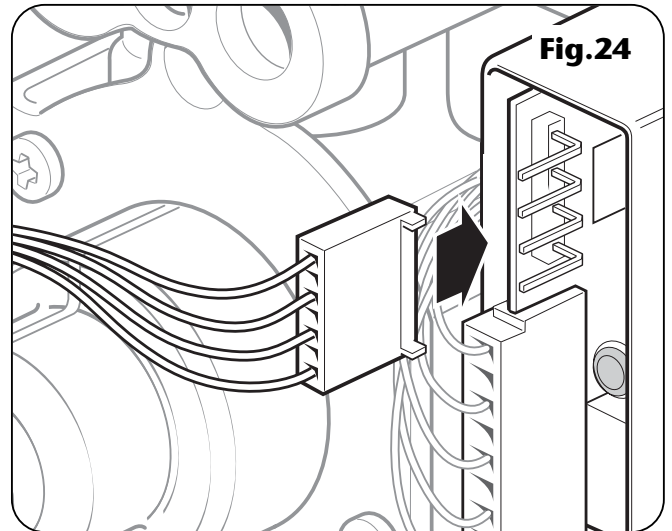

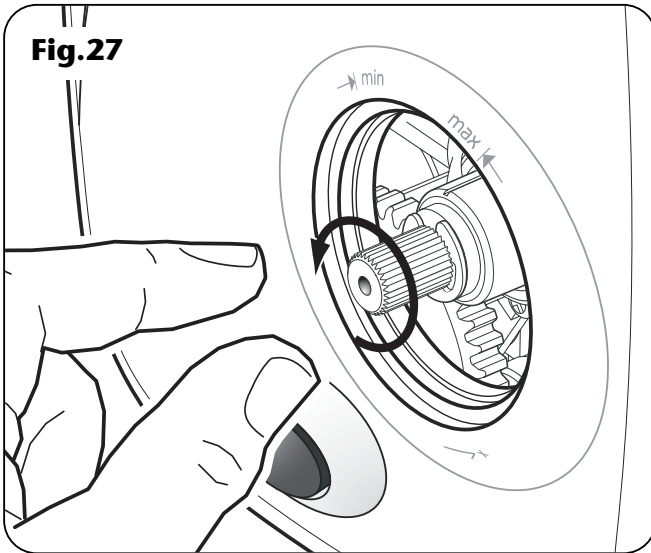

With your fingers, rotate the valve spindle fully anti-clockwise (**fig.27**) to the fully hot position.

Replace the flow control so that it aligns with the 'min' position.

Fit the temperature disc (it will only fit one way) and maximum temperature stop (**fig.28**).

Note: If adjustment of the maximum temperature stop is required, refer to section 'Adjusting the maximum temperature stop'.

Replace the temperature control onto the valve spindle. Make sure the pointer aligns with setting '9' on the temperature disc (**fig.29**).

Secure with the retaining screw and fit the cover trim.

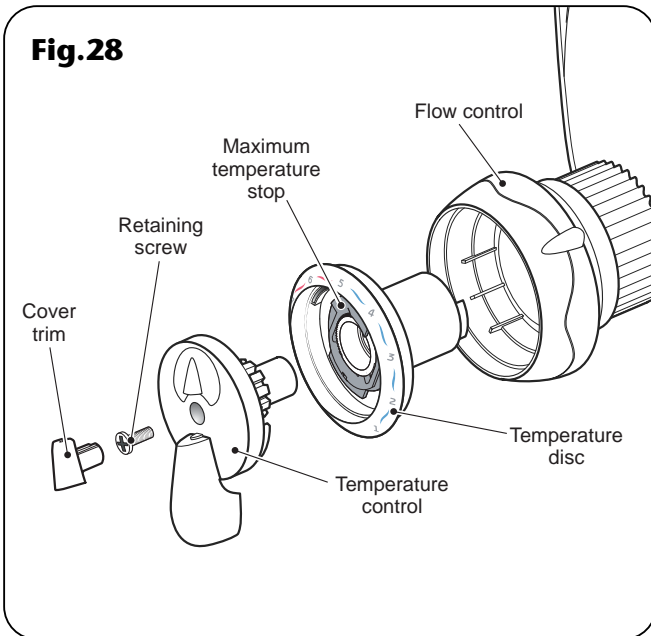

Switch on the electricity supply at the isolating switch. Make sure both water supplies are still turned on.

Once the installation of the riser rail is complete, the shower is ready for normal operation.

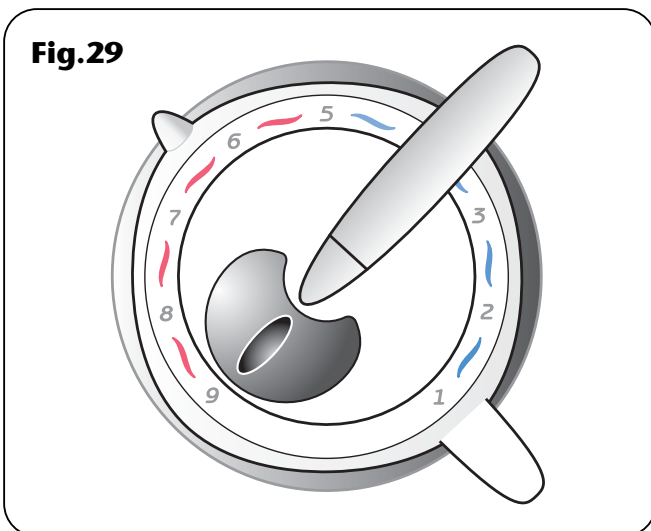

FITTING THE RISER RAIL

WARNING!

Check there are no hidden cables or pipes before drilling holes for wall plugs. Use great care when using power tools near water. The use of a residual current device (RCD) is recommended.

Decide the position for the rail on the wall within the shower area. Proceed as follows:

Fit the sprayhead holder onto the riser rail. The correct orientation of the holder is when the sprayhead holder is sloping **DOWN (fig.30)**.

To fit the sprayhead holder onto the riser rail unit, press and hold the button on the underneath of the sprayhead holder to release the locking mechanism, then slide onto the rail.

Slide the supplied soap dish onto the riser rail below the sprayhead holder **(fig.31)**.

Slide the top and bottom finishing trims onto the riser rail **(fig.32)**.

Push the two fixing brackets into the ends of the riser rail **(fig.33)**.

Offer the rail assembly to the wall **(fig.34)**. Using the brackets as templates, mark two upper holes and two lower holes. Note there are four provisions for screws per bracket – select the two most suitable for your requirements. Make sure the rail is aligned vertically.

Drill and plug the wall. *(The wallplugs provided are suitable for most brick walls – use an appropriate masonry drill, but if the wall is plasterboard or a soft building block, use special wallplugs and an appropriate drill bit).*

Screw to the wall with the fixing screws supplied.

Slide the finishing trims onto the brackets. Make sure the lug on each rail bracket end engages into the slot on the fatter end of each trim before push fitting the thinner ends in place **(fig.35)**.

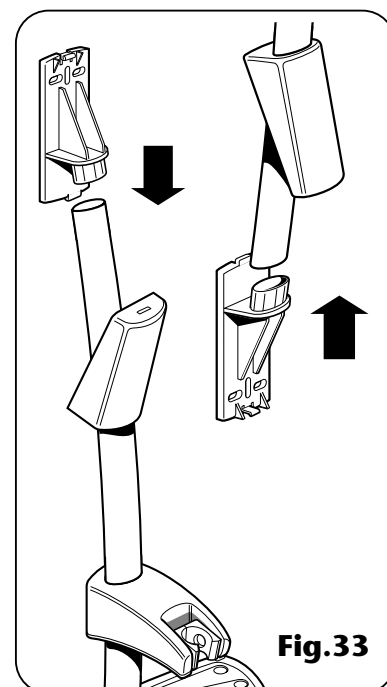
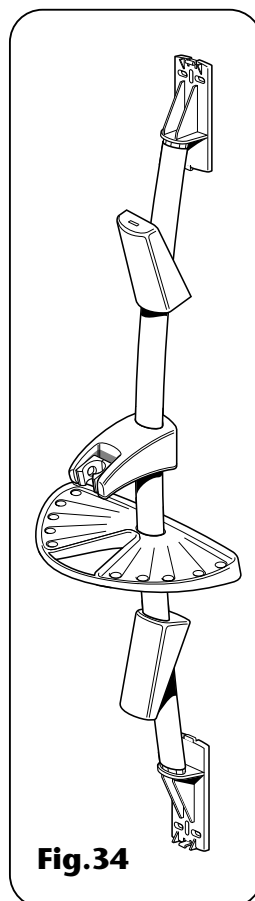
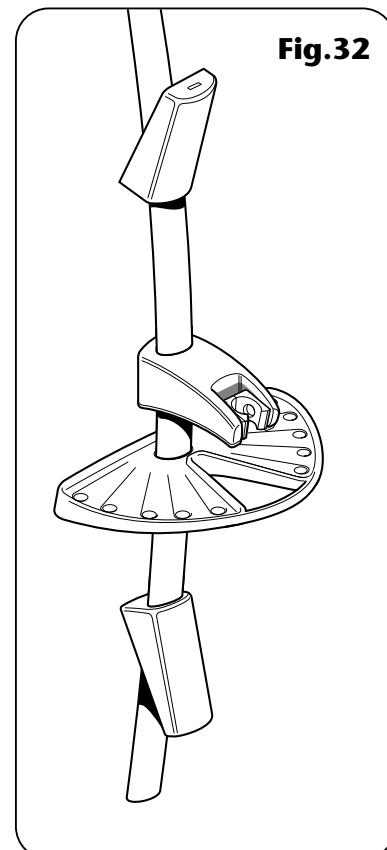
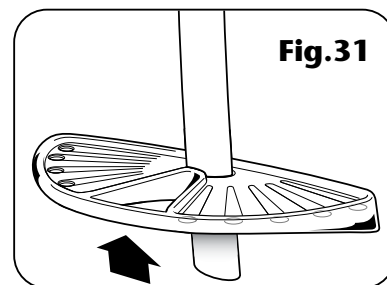
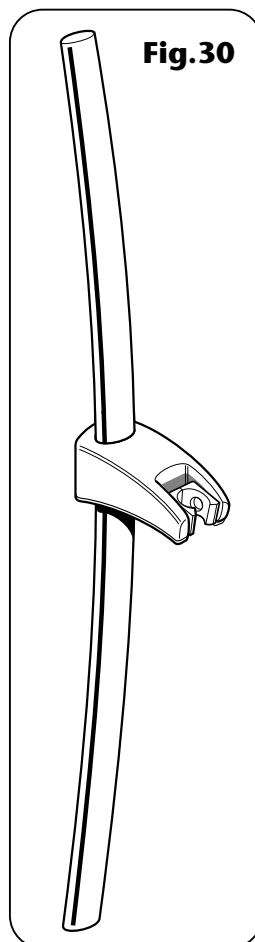
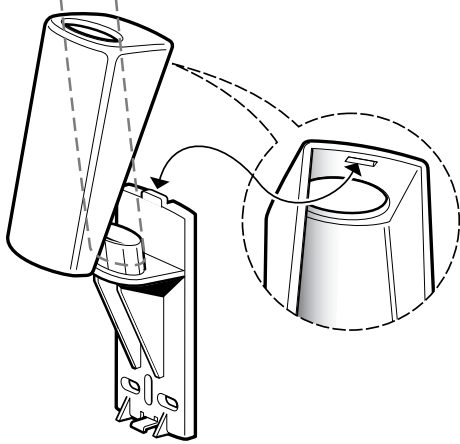

Fig.35



To remove a trim, push a small screwdriver or similar through the slot in the trim end and carefully pull away from the wall bracket.

Slide the soap dish down the rail so that its bracket engages on top of the lower finishing trim.

Adjusting the sprayhead holder

To adjust the height, press the button underneath the holder to release the locking mechanism (**fig.36**). Still pressing the button, move the holder up or down to suit user's requirement.

Fig.36

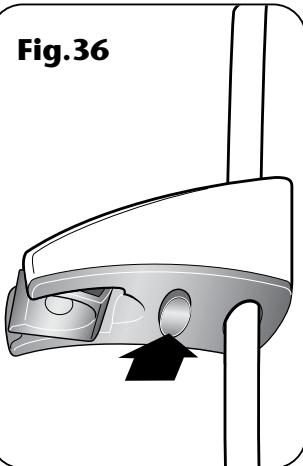
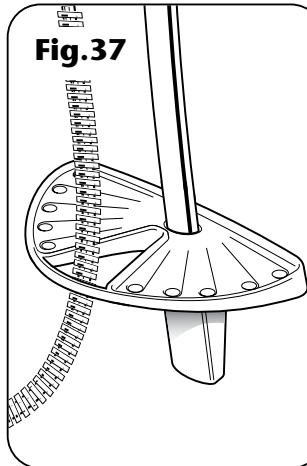

Fig.37



Fitting the hose and sprayhead

Feed the flexible hose through the soap dish aperture (**fig.37**) so the dish acts as a retaining ring (Water Regulations).

Screw the flexible hose to the shower outlet and sprayhead, checking the supplied washers are in place at both ends of the flexible hose (**fig.38**).

Place the sprayhead into the holder and check that it fits correctly (**fig.39**).

Note: The holder is slightly tapered and the sprayhead and hose will only fit from one direction.

IMPORTANT: It is the conical end of the hose which grips into the holder. The sprayhead will not fit in the holder without the hose attached. At this stage, disconnect the sprayhead and lay aside until the shower unit has been commissioned.

Fig.38

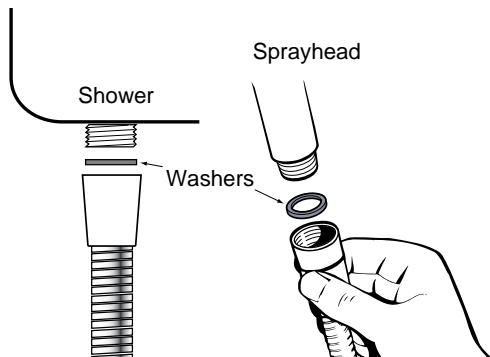
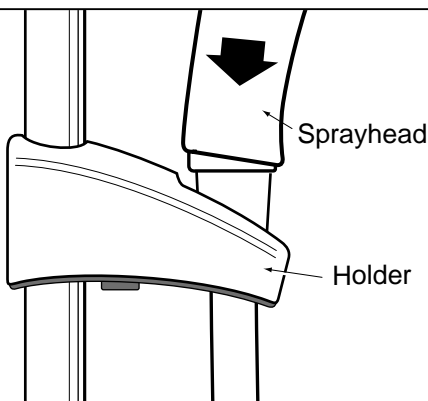

Fig.39



OPERATING THE SHOWER

Check all plumbing and electrical supplies are connected and switched on.

To start the shower, press the 'Start/Stop' button (**fig.40**).

Adjust the control (**fig.41**) until the flow rate is satisfactory.

For maximum flow, turn the flow control fully anti-clockwise. For minimum flow, rotate the flow control fully clockwise.

To adjust the temperature rotate the control (**fig.42**). The temperature is numbered for ease of use. The temperature ranges from '1' – fully cold to '9' – fully hot.

Once the preferred temperature is reached, no further adjustment is required, providing the hot and cold water supplies remain constant.

To stop the shower, press the 'Start/Stop' button once more. This stops the pump and water flow.

Unless the shower is to be used again immediately, the shower should also be switched off at the electricity isolating switch.

As a safety feature, the temperature control has a built-in stop to prevent you accidentally exceeding your highest desired temperature. If adjustment is required see section 'Adjusting the maximum temperature stop'.

To override this stop, depress the button (**fig.43**) while the control is up against the stop and turn the control anti-clockwise to the higher settings (pressing the button before the stop will not operate the override mechanism even if the control is turned with the button depressed).

To return to the normal temperature range just turn the temperature control clockwise until it is past the maximum temperature stop. Make sure the temperature control is in the normal temperature range when the shower is switched off. The stop comes in a factory set position based on 65°C stored hot water temperature.

CAUTION: It is recommended that persons who may have difficulty understanding or operating the shower controls should not be left unattended whilst showering. Special consideration should be given to young children and the less able bodied.

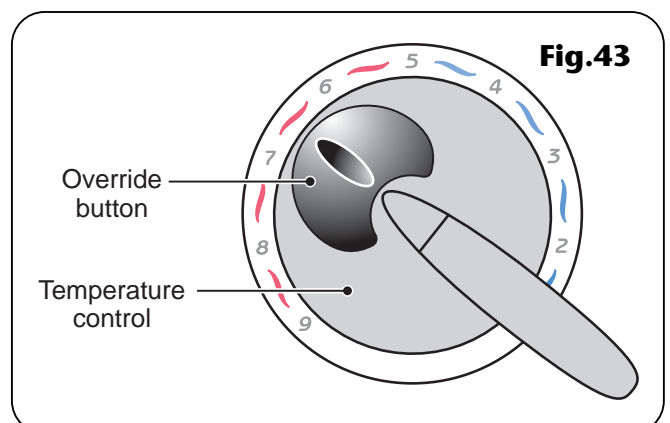
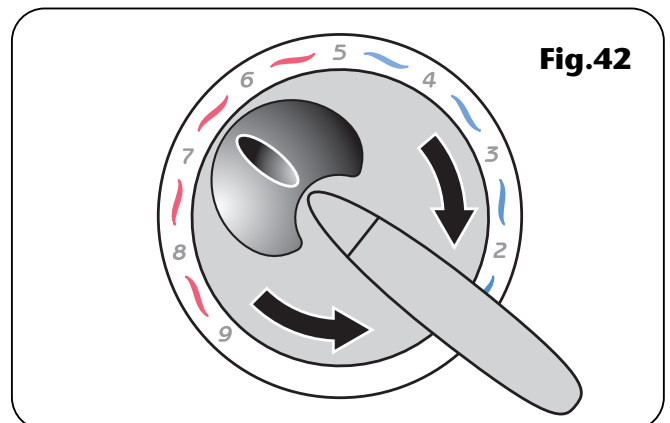
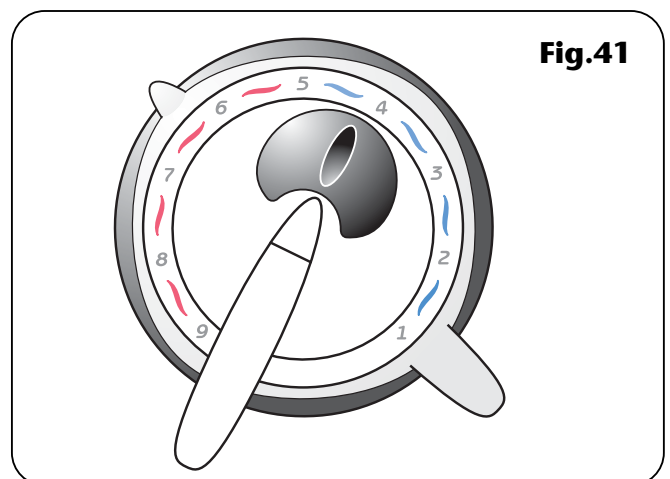
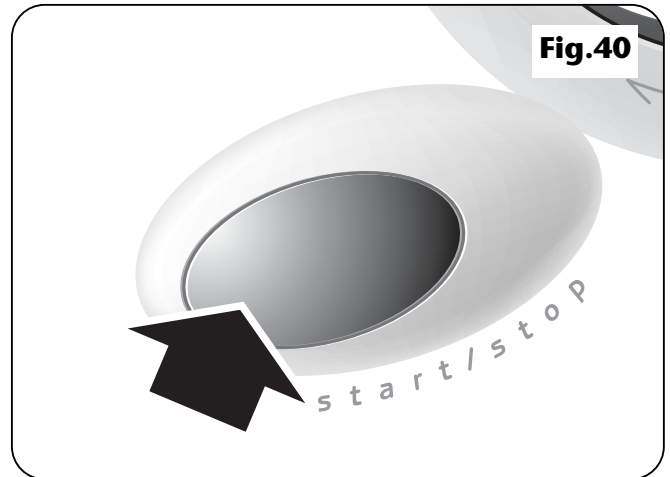

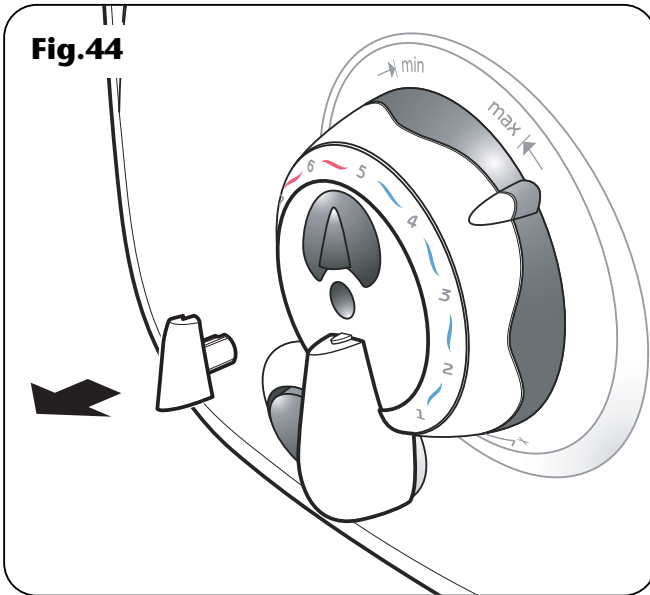

Note: As the flow control is adjusted it is normal for the sound of the pump to alter in pitch.

ADJUSTING THE MAXIMUM TEMPERATURE STOP

WARNING!

The manual shower does not contain a thermostatic valve – it will not shut off in the event of failure of either the hot or cold water supplies.

As a safety feature the shower has a built-in maximum temperature stop to prevent you accidentally exceeding your highest desired temperature. This is set in the factory to provide a maximum temperature based on the hot and cold water supplies being 65°C and 15°C respectively.

IMPORTANT: Only adjust the maximum temperature stop when the hot water is at its usual storage temperature.

Procedure

Rotate the temperature control to setting '9' on the temperature disc.

Remove the cover trim to reveal the retaining screw (**fig.44**).

Undo the retaining screw and carefully pull off the temperature control, making sure it is still aligned to setting '9'.

Now remove the maximum temperature stop.

To increase the temperature stop setting, reposition the mechanism anti-clockwise within the arc of the grooves (**fig.45**).

To decrease the temperature stop setting, reposition the mechanism clockwise within the arc of the grooves (**fig.45**).

Replace the temperature control onto the valve spindle. Make sure the pointer aligns with setting '9' on the temperature disc (**fig.28**).

Secure with the retaining screw and refit the cover trim.

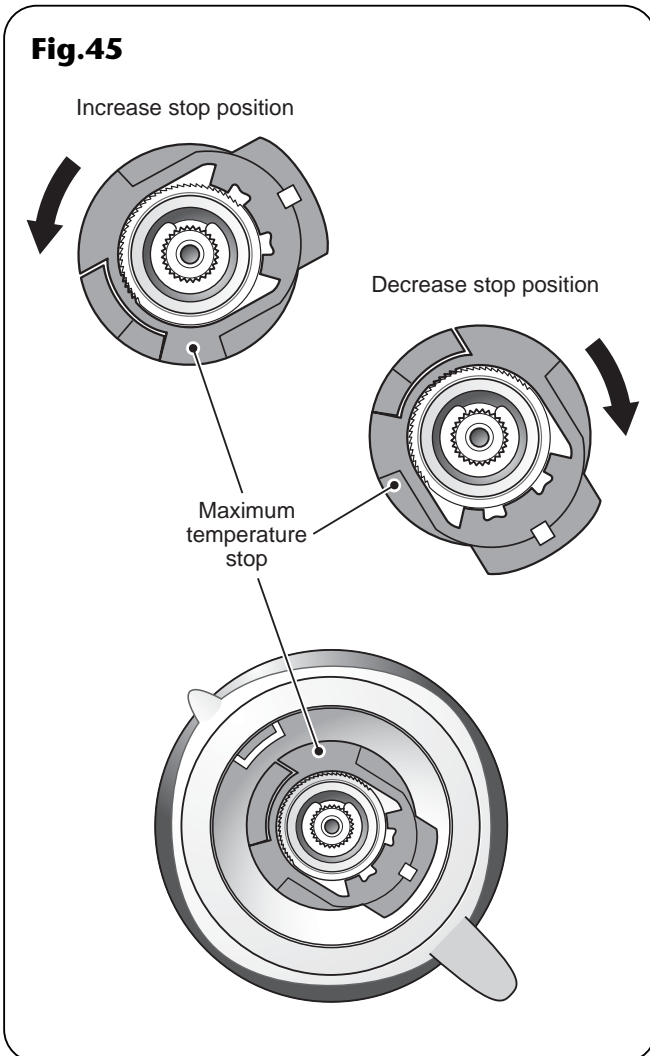

ADJUSTING THE SPRAYHEAD

Five sprayhead patterns are available (**fig.46**). Adjustment is by turning the bezel on the sprayhead in either direction until the desired pattern is obtained.

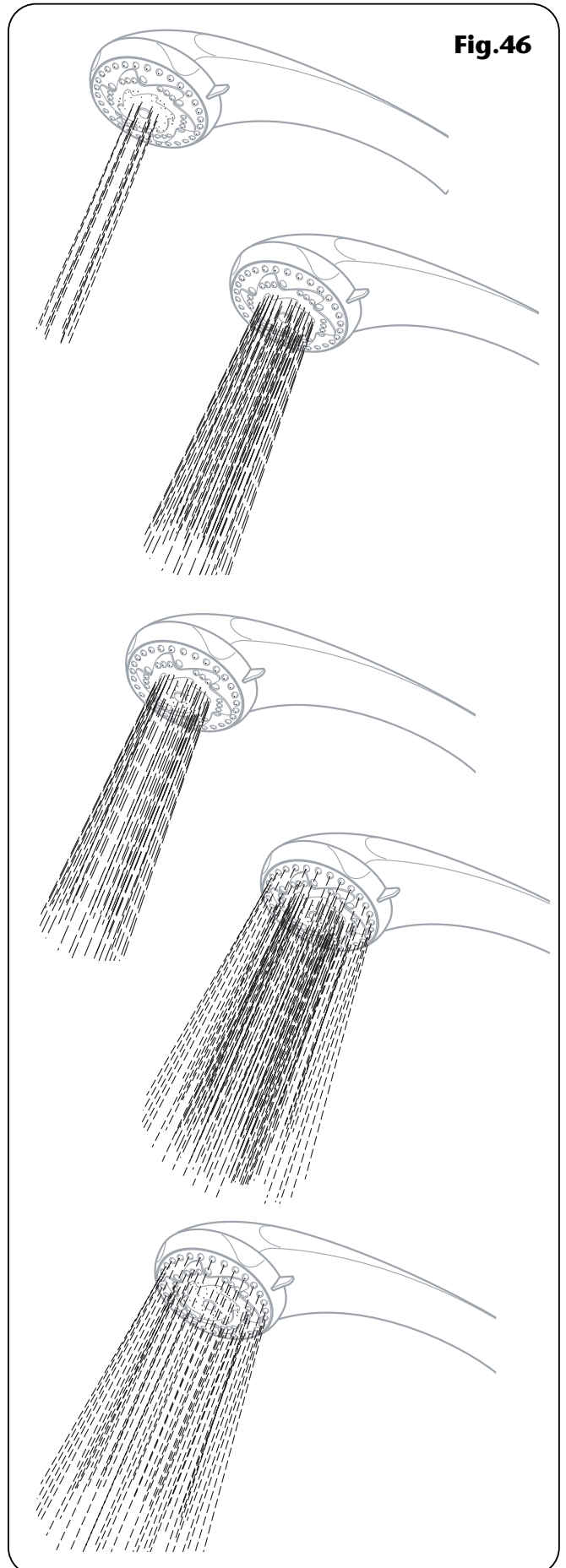

Fig.47

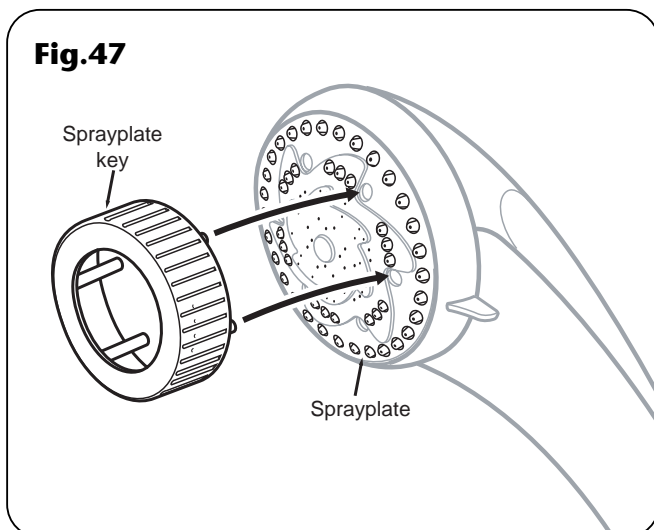
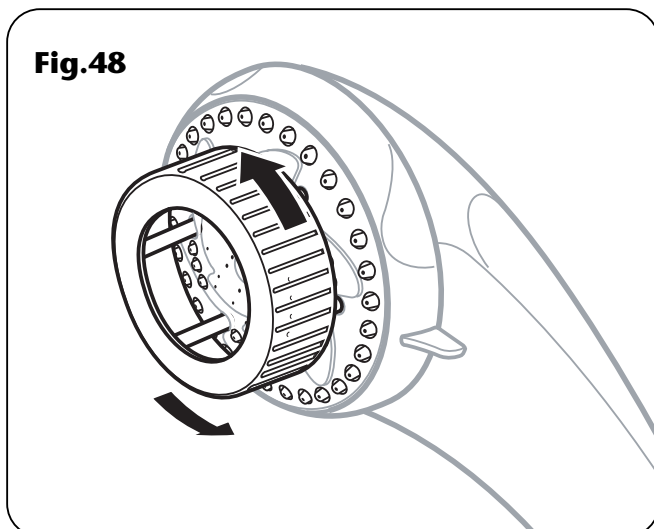

Fig.48



CLEANING

WARNING!

DO NOT use 'powerful' abrasive or solvent cleaning fluids when cleaning the shower as they may damage the plastic fittings.

Before cleaning, turn off the unit at the isolation switch to avoid the shower being accidentally switched on.

IT IS IMPORTANT TO KEEP THE SPRAYHEAD CLEAN TO MAINTAIN THE PERFORMANCE OF THE SHOWER. The hardness of the water will determine the frequency of cleaning. For example, if the shower is used every day in a very hard water area, it may be necessary to clean the sprayhead on a weekly basis.

Sprayplate removal

There is no need to remove the sprayhead from the hose.

Using the removal tool supplied (**fig.47**), locate the three raised 'bosses' into the three recesses in the sprayplate. Hold in firmly and twist anti-clockwise (**fig.48**). This movement may turn the cartridge assembly as well until it reaches a 'stop'.

Hold the cartridge firmly and continue to twist anti-clockwise. Having loosened the sprayplate sufficiently, it can be unscrewed and removed completely.

Clean the sprayplate with a suitable brush or preferably leave it to soak overnight in a mild proprietary descaler. Make sure all traces of scale are removed and thoroughly rinse in clean water afterwards.

Before replacing the sprayplate, switch the power back on at the isolating switch and direct the hose and sprayhead to waste.

Turn the flow control fully anti-clockwise.

Press the start/stop button. This operation will flush out any loose scale deposits in the unit and sprayhead. Stop after about thirty seconds.

Refit the sprayplate by screwing clockwise. Use the tool to screw the sprayplate tight.

INSTRUCTIONS FOR INSTALLERS AND SERVICE ENGINEERS ONLY

CLEANING THE FILTERS

Note: Turn off the electricity and both hot and cold water supplies to the unit before proceeding further.

To remove the cover, first pull off the flow knob cover trim (**fig.6**) to reveal the retaining screw.

Undo the screw and pull off the temperature control. Now remove the outer flow control assembly comprising of the flow control, maximum temperature stop and temperature disc.

Remove the two cover fixing screws – top and bottom (**fig.8**). Carefully lift the cover away from the backplate. To release the PCB connector, squeeze the connection block arms and pull apart.

Remove the single retaining screw from either the upper or lower filter cover (**fig.49**), depending upon whether top/rear entry or bottom entry is used. Pull off the filter cover. Carefully hook out the filters together with 'O' rings. Thoroughly clean and replace making sure the 'O' rings are in position.

Refit the filter cover and secure with the retaining screw.

Make sure the potentiometer control is rotated fully anti-clockwise (**fig.25**).

With your fingers, rotate the valve spindle fully anti-clockwise (**fig.26**) to the fully hot position.

Fit the cover, making sure the PCB connector is fitted and the wires are clear of obstructions. Secure with the top and bottom fixing screws (**fig.8**).

Replace the flow control so that it aligns with the 'min' position.

Fit the temperature disc (it will only fit one way) and maximum temperature stop (**fig.27**).

Replace the temperature control onto the valve spindle. Make sure the pointer aligns with setting '9' on the temperature disc (**fig.28**).

Secure with the retaining screw and fit the cover trim.

Switch on the electricity supply to the unit and then turn on both water supplies.

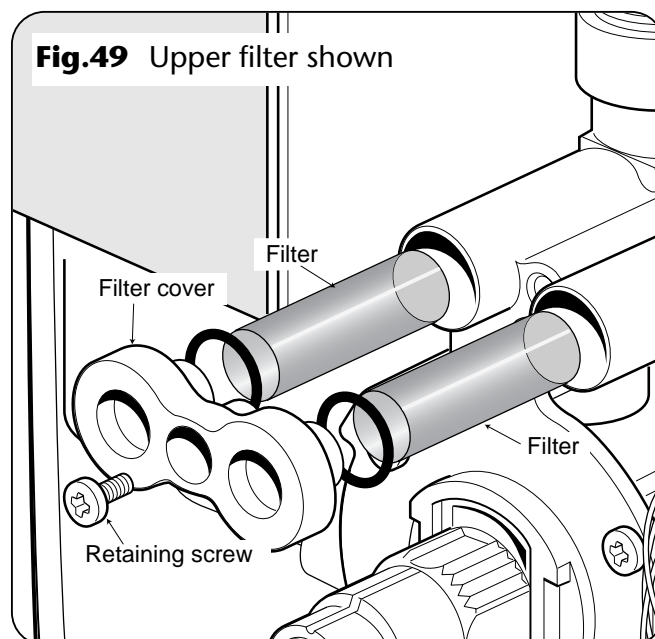

SPARE PARTS

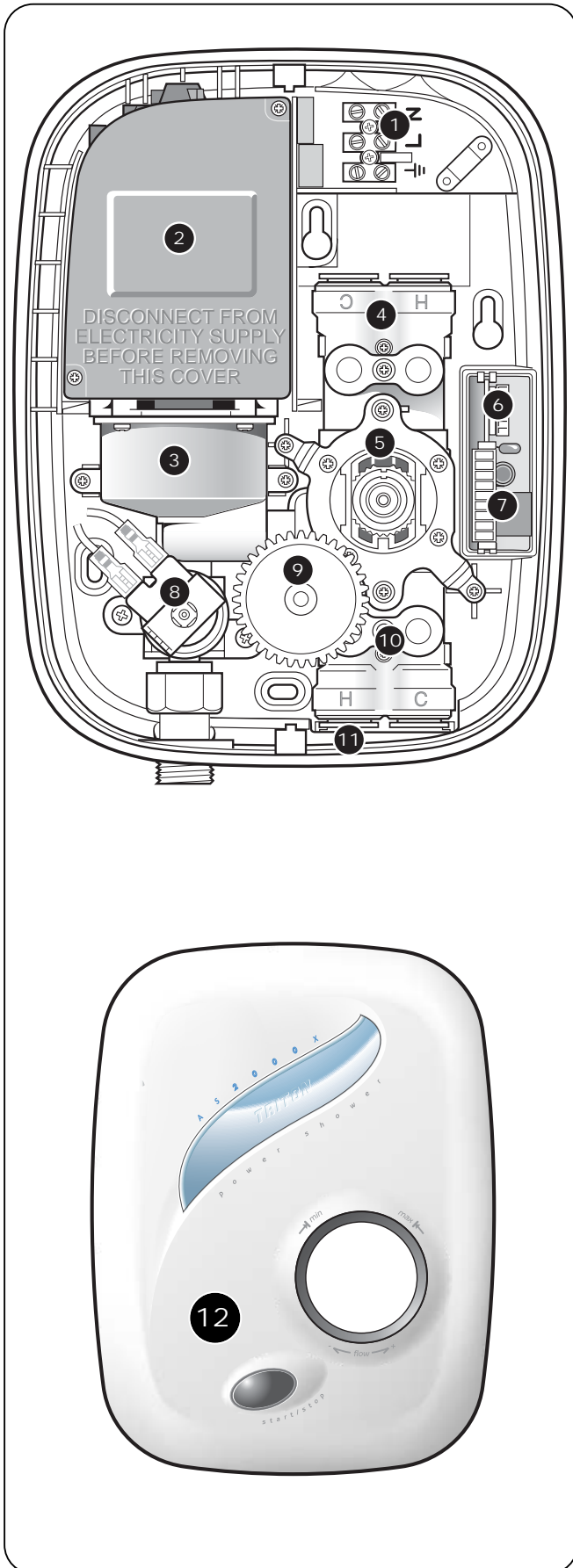

Ref.	Description	Part No.
1	Terminal block	22001320
2	Motor cover	83305300
3	Pump and motor assembly	83305290
4	Pipe inlet elbow c/w filters and check valves	83305320
5	Temperature valve	83305280
6	Link pin	22009060
7	PCB unit	7072177
8	Solenoid assembly	82300430
9	Gear	7052184
10	Filter (pair)	83305330
11	Plastic inlet elbow plug	7052140
-	Pipe trim	7052146
-	Pipe removing tool	7052144
-	Potentiometer harness	P09440900
-	Bracket	7052183
-	Wire kit	83305340
12	Cover assembly	P09440600
-	Maximum temperature stop	7052186
-	Temperature control c/w override button	P09441000
-	Flow control	7053275
-	Temperature disc	7053277
-	Flow control trim	7053276
-	Temperature control cover trim	7053280
-	Rear entry elbow	22008180

SPARE PARTS

Ref.	Description	Part No.
13	5 mode sprayhead	22011070
14	Brackets (pair)	22010430
15	Cover trims (pair)	22010440
16	Riser rail - chrome	22010750
17	Sprayhead holder	22010460
18	Soap dish	22010470
19	Flexible hose	28100000

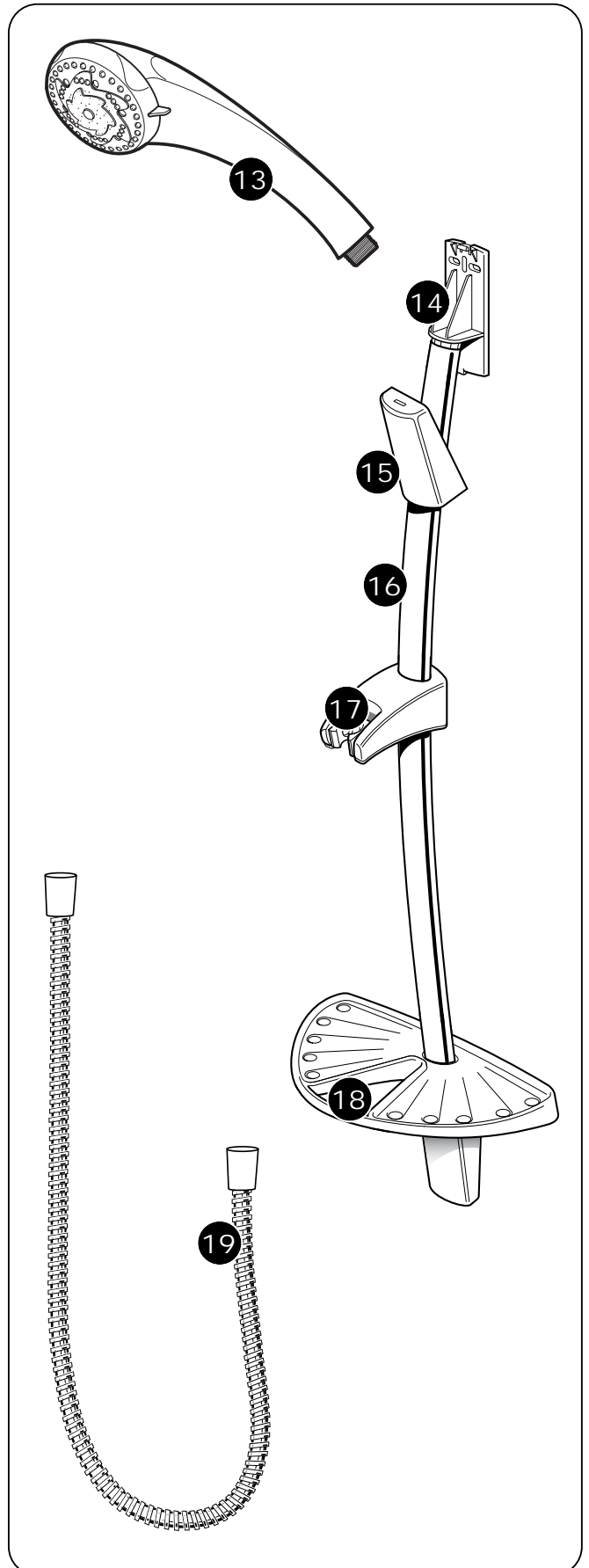

FAULT FINDING

IMPORTANT: Switch OFF the electricity at the mains supply and remove the correct circuit fuse before attempting any fault finding inside the unit.

Symptom	Cause	Action/Cure
1 Water too hot.	1.1 Not enough cold water flowing through shower.	1.1.1 Turn the temperature control clockwise.
	1.2 Increase in the ambient cold water temperature.	1.2.1 Turn the temperature control clockwise.
	1.3 Cold inlet filter blocked or check valve sticking.	1.3.1 Remove filter and clean. If problem is with check valve, contact Customer Service.
	1.4 Cold water supply blocked or cut off.	1.4.1 Isolate shower and consult a competent plumber or contact Customer Service.
2 Water too cold.	2.1 Not enough hot water flowing through shower.	2.1.1 Turn temperature control anti-clockwise.
	2.2 Decrease in ambient cold water temperature.	2.2.1 Turn temperature control anti-clockwise.
	2.3 No hot water in the storage cylinder.	2.3.1 Turn shower off and wait for hot water cylinder to reheat.
	2.4 Hot inlet filter blocked or check valve sticking.	2.4.1 Remove filter and clean. If problem is with check valve, contact Customer Service.
	2.5 Hot water supply blocked or otherwise cut off.	2.5.1 Turn shower off. Consult a competent plumber or contact Customer Service.
3 Pump does not operate.	3.1 Interrupted power supply.	3.1.1 Blown fuse. Check supply. Renew fuse. If it fails again consult a competent electrician.
		3.1.2 Power cut. Check other appliances and if necessary, contact local Electricity Supply Co.
	3.2 Electrical malfunction.	3.2.1 Consult a competent electrician or contact Customer Service.
	3.3 Motor overheated.	3.3.1 Thermal protection on motor has operated. Allow appliance to cool and reset itself. If it persists, contact Customer Service.

Any maintenance or repair to the shower must be carried out by a suitably competent person.

FAULT FINDING

<i>Symptom</i>	<i>Cause</i>	<i>Action/Cure</i>
	3.4 Start/stop switch not connected.	3.4.1 Remove cover and connect start/stop switch.
4 Water does not flow or is reduced.	4.1 Water supplies cut off. 4.2 Shower blocked or air in the system. 4.3 Sprayhead blocked. 4.4 Blocked filters.	4.1.1 Check water elsewhere in house and if necessary contact the local Water Company. 4.2.1 Switch off shower and contact Customer Service. 4.3.1 Clean sprayhead. 4.4.1 Clean filters.
5 Cross flow of hot and cold water into system.	5.1 Dirt/debris in check valves.	5.1.1 Isolate water to unit. Remove check valves. Clean and replace.
6 Water dripping from sprayhead when turned off.	6.1 Debris in solenoid valve. 6.2 Potentiometer faulty.	6.1.1 Call Customer Service. 6.2.1 Call Customer Service.
7 Pump is noisy or air lock in pump.	7.1 Air lock in pump. 7.2 Worn pump bearings.	7.1.1 Call Customer Service. 7.2.1 Replace pump.
8 Water flowing from inside the unit.	8.1 Blanking plugs not fitted into unused inlets.	8.1.1 Fit blanking plugs into unused inlets.

**In the unlikely event of a fault occurring please contact Triton Customer Service.
Do not remove the shower from the installation.**



Service Policy

In the event of a complaint occurring, the following procedure should be followed:

- 1 Telephone Customer Service on (024) 7637 2222 (08457 626591 in Scotland and in Northern Ireland), having available the model number and power rating of the product, together with the date of purchase.
- 2 Triton Customer Service will be able to confirm whether the fault can be rectified by either the provision of a replacement part or a site visit from a qualified Triton service engineer.
- 3 If a service call is required it will be booked and the date of call confirmed. In order to expedite your request, please have your postcode available when booking a service call.
- 4 It is essential that you or an appointed representative (who must be a person of 18 years of age or more) is present during the service engineer's visit and receipt of purchase is shown.
- 5 A charge will be made in the event of an aborted service call by you but not by us, or where a call under the terms of guarantee has been booked and the failure is not product related (i.e. scaling and furring, incorrect water pressure, pressure relief device operation, electrical installation faults).
- 6 If the product is no longer covered by the guarantee, a charge will be made for the site visit and for any parts supplied.
- 7 Service charges are based on the account being settled when work is complete, the engineer will then request payment for the invoice. If this is not made to the service engineer or settled within ten working days, an administration charge will be added.

Replacement Parts Policy

Availability: It is the policy of Triton to maintain availability of parts for the current range of products for supply after the guarantee has expired. Stocks of spare parts will be maintained for the duration of the product's manufacture and for a period of five years thereafter.

In the event of a spare part not being available a substitute part will be supplied.

Payment: The following payment methods can be used to obtain spare parts:

- 1 By post, pre-payment of pro forma invoice by cheque or money order.
- 2 By telephone, quoting credit card (MasterCard or Visa) details.
- 3 By website order, www.tritonshowers.co.uk

TRITON STANDARD GUARANTEE

Triton Plc guarantee this product against all mechanical and electrical defects arising from faulty workmanship or materials for a period of one year for domestic use only, from the date of purchase, provided that it has been installed by a competent person in full accordance with the fitting instructions.

Any part found to be defective during this guarantee period we undertake to repair or replace at our option without charge so long as it has been properly maintained and operated in accordance with the operating instructions, and has not been subject to misuse or damage.

This product must not be taken apart, modified or repaired except by a person authorised by Triton Plc. This guarantee applies only to products installed within the United Kingdom and does not apply to products used commercially. This guarantee does not affect your statutory rights.

What is not covered:

- 1 Breakdown due to: *a)* use other than domestic use by you or your resident family; *b)* wilful act or neglect; *c)* any malfunction resulting from the incorrect use or quality of electricity, gas or water or incorrect setting of controls; *d)* faulty installation.
- 2 Repair costs for damage caused by foreign objects or substances.
- 3 Total loss of the product due to non-availability of parts.
- 4 Compensation for loss of use of the product or consequential loss of any kind.
- 5 Call out charges where no fault has been found with the appliance.
- 6 The cost of repair or replacement of pressure relief devices, sprayheads, hoses, riser rails and/or wall brackets, isolating switches, electrical cable, fuses and/or circuit breakers or any other accessories installed at the same time.
- 7 The cost of routine maintenance, adjustments, overhaul modifications or loss or damage arising therefrom, including the cost of repairing damage, breakdown, malfunction caused by corrosion, furring, pipe scaling, limescale, system debris or frost.

Customer Service: ☎ (024) 7637 2222

**Scottish and Northern Ireland
Customer Service:** ☎ 08457 626591

Trade Installer Hotline: ☎ (024) 7632 5491
Fax: (024) 7632 4564

www.tritonshowers.co.uk

E mail: technical@triton.plc.uk

Triton Plc
Shepperton Park
Caldwell Road
Nuneaton
Warwickshire CV11 4NR