

Alterna

Amala concentric mixer shower

Installation
and operating
instructions



INSTALLERS PLEASE NOTE THESE INSTRUCTIONS ARE TO BE LEFT WITH THE USER

CONTENTS	Page
Introduction.....	1
Safety warnings	1
Main components	2
Site requirements	3
Typical suitable installations.....	4 – 5
Getting started.....	6
Siting of the shower.....	6
Installation	7 – 14
General conditions	7 – 8
Option 1: Exposed fitting	
Rising or falling supplies	9
Rear entry supplies.....	9 – 10
Fitting the mixer	10
Leak testing.....	10
Option 2: Built-in fitting	
Building-in depth	11
Solid wall, hollow wall and panel mounting.....	11 – 12
Fitting the bulkhead pipework	13
Leak testing.....	13
Making good	14
Fitting the trimplate.....	14
Bulkhead assembly	15
Commissioning.....	16
Adjusting the maximum temperature setting	16
Operating the shower	17
Cleaning	17
Spare parts.....	18 – 19
Fault finding	19 – 20
Guarantee, service policy, etc.	rear cover

To check the product suitability for commercial and multiple installations, please contact specification advisory service before installation.

Telephone: 0844 980 0748

Facsimile: 0844 980 0744

INTRODUCTION

This book contains all the necessary fitting and operating instructions for your Alterna Amala concentric mixer shower. Please read them carefully.

Read through the whole of this book BEFORE beginning your installation.

The shower installation MUST be carried out by a suitably competent person and in sequence of this instruction book.

Care taken during the installation will give a long and trouble free life from your shower.

For best performance within the specified running pressure range a minimum flow of 8 litres per minute should be available to both inlets.

The mixer shower MUST NOT be subjected to water temperatures above 80°C.

This mixer shower is designed for use with traditional low pressure 'gravity' water systems, using a cold water cistern and hot water cylinder as well as for the higher pressure systems found in the UK up to a maximum of 5 bar running pressure.

IMPORTANT: When installing this mixer with a combination boiler or multi-point, flow regulators may be installed if required in the inlet elbows.

This mixer shower is suitable for fully modulating type combination boilers and multi-point hot water heaters. It is also suitable for thermal storage, unvented systems and pumped gravity systems.

IMPORTANT: Before installing with a gas instantaneous water heater, make sure it is capable of delivering hot water at a minimum switch-on flow rate of 3 litres per minute. At flow rates between 3 and 8 litres per minute, the appliance must be capable of raising the water temperature to a minimum of 52°C.

Water temperature at the mixer inlet must remain relatively constant when flow rate adjustments are made (*refer to the water heater operating manual to confirm compatibility with this mixer shower*).

This mixer shower is supplied with an integral large area filter in each inlet elbow. Inlet connections are by compression fittings for 15mm copper pipe.

SAFETY WARNINGS

- a. Layout and sizing of pipework MUST be such that when other services are used, pressures at the shower control inlets DO NOT fall below the recommended minimum.
- b. DO NOT choose a position where the shower could become frozen.
- c. DO NOT connect this mixer shower to any form of tap or fitting not recommended by the manufacturer.
- d. The showerhead MUST be regularly cleaned to remove scale and debris.
- e. Conveniently situated isolating valves in each inlet supply MUST be fitted as an independent method of isolating the shower should maintenance or servicing be necessary.
- f. If it is intended to operate the shower in areas of hard water (above 200 ppm temporary hardness), a scale inhibitor may have to be fitted. For advice on a scale inhibitor, please contact Customer Service.
- g. DO NOT operate the shower outside the guidelines as laid out in '*site requirements*'.

Replacement parts can be ordered from Customer Service. See '*spare parts*' for details and part numbers.

MAIN COMPONENTS (fig.1)

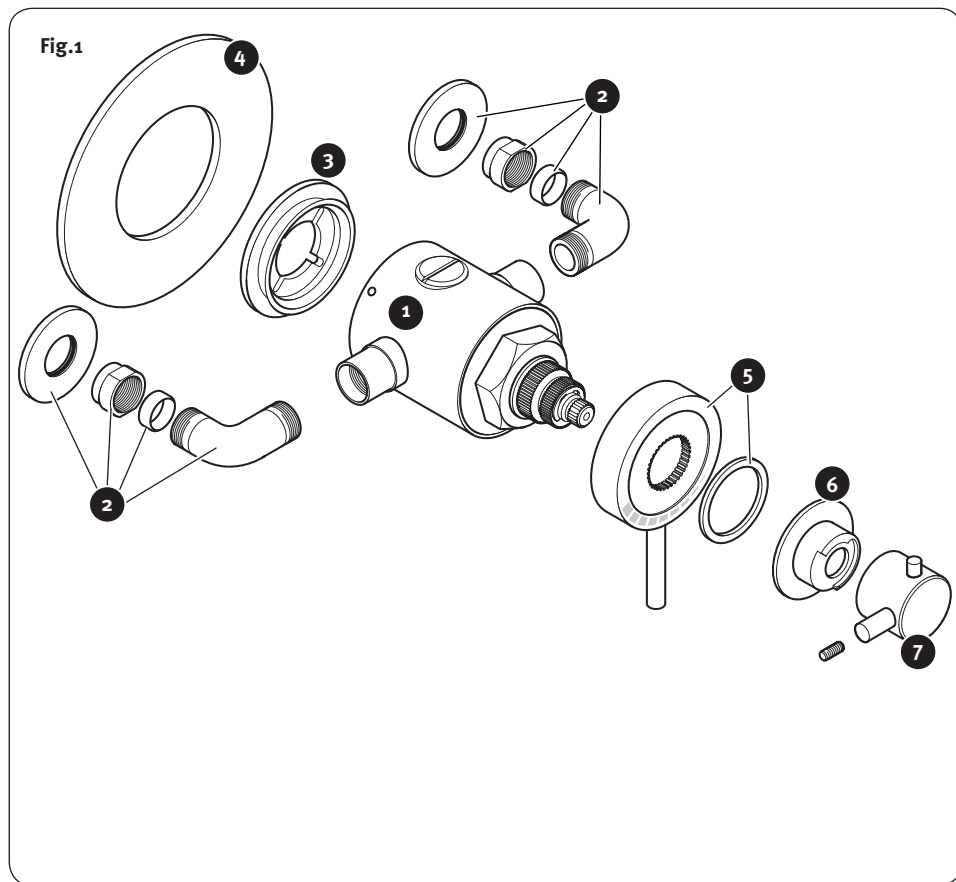

- 1. Mixer shower body
- 2. Inlet elbow including:
 - Inlet nut
 - Olive
 - Rear pipe trim
- Flow regulators (HP systems only)
- 3. Mounting plate
- 4. Trimplate
- 5. Flow control including silicon ring
- 6. Temperature stop
- 7. Temperature control
 - Showerhead
 - Flexible hose

SITE REQUIREMENTS

The installation MUST be in accordance with Water Regulations and Bylaws.

Running water pressure:

- Gravity fed – 0.1 bar min.
1.0 bar max.
- Mains fed – 1.0 bar min.
5.0 bar max.

Maximum static water pressure:

- Gravity and mains – 10 bar

DO NOT connect the mixer shower to a gravity hot supply and a mains cold supply (or vice versa).

For best performance within the specified running pressure range a minimum flow of eight litres per minute should be available to both inlets.

While the mixer shower is operational (open outlet), inlet pressures MUST NOT be capable of exceeding 7 bar. For effective operation of the internal seals, the maximum static pressure must not be exceeded.

Note: On sites where the running pressure is above 5 bar, the use of a suitably sized pressure reducing valve fitted in the cold mains supply pipework can provide nominally equal pressures at the mixer shower.

The pipework should be installed such that the flow is not significantly affected by other taps and appliances being operated elsewhere on the premises.

Note: Where thermal store systems and instantaneous gas water heaters are used, if excessive draw-offs take place the boiler may not be able to maintain an adequate output temperature. This could result in the shower temperature becoming noticeably cooler.

Water temperature requirements

Maximum hot water temperature:	80°C
Recommended maximum:	65°C
Minimum hot water temperature:	52°C
Maximum cold water temperature:	20°C

BS 6700 recommends that the temperature of stored water should never exceed 65°C.

A stored water temperature of 60°C is considered sufficient to meet all normal requirements and will minimise the effects of scale in hard water areas.

Temperature adjustment range

The mixed water temperature can be adjusted from cold through to a top limit which must be preset during installation with full anti-scald protection throughout the range (35°C to 40°C) providing the hot water temperature at the inlet remains 10°C above the outlet temperature.

Should there be a loss of flow to either incoming supply then water from the shower will stop or be reduced to a trickle until both supplies are restored.

Fig.2 (diagrammatic view – not to scale)

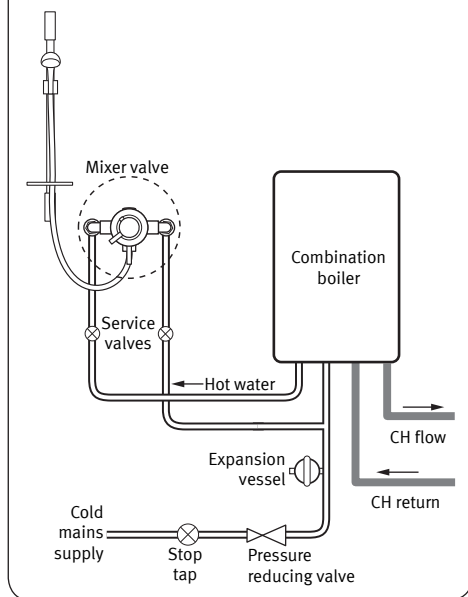

TYPICAL SUITABLE INSTALLATIONS

a) Instantaneous gas-heated systems, e.g. combination boilers (fig.2)

The shower control MUST be installed with a multipoint gas water heater or combination boiler of a fully modulating design (i.e. to maintain relatively stable hot water temperatures).

A drop tight pressure reducing valve MUST be fitted if the supply pressures exceed 5 bar running.

An expansion vessel, shown in **fig.2**, MUST be fitted, and regularly maintained, to make sure the shower mixer is not damaged by excess pressures. This may already be installed within the boiler (*check with manufacturer*) and is in addition to the normally larger central heating expansion vessel.

The layout and sizing of pipework MUST be such that nominally equal inlet supply pressures are achieved and the effects of other draw-offs are minimised.

The hot supply temperature MUST remain a minimum of 10°C hotter than the required blend temperature for best performance.

Fig.3 (diagrammatic view – not to scale)

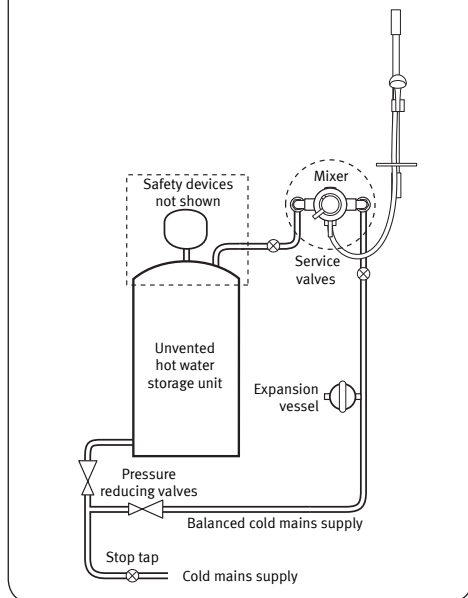

b) Unvented mains pressure systems (fig.3)

The shower control can be installed with an unvented, stored hot water cylinder.

For systems with no cold water take off after the appliance reducing valve, it will be necessary to fit an additional drop tight pressure reducing valve when the mains pressure is over 5 bar. The drop tight pressure reducing valve must be set at the same value as the unvented package pressure reducing valve.

Note: An additional expansion vessel (**fig.3**) may be required if a second pressure reducing valve is installed. This does not apply to packages with a cold take off after the pressure reducing valve to the cylinder.

The layout and sizing of pipework MUST be such that nominally equal inlet supply pressures are achieved and the effects of other draw-offs are minimised.

c) Main pressurised thermal store systems (fig.4)

Packages of this type, fitted with a tempering valve (blender valve) can be used. A drop tight pressure reducing valve must be fitted if the supply pressures exceed 5 bar running.

An expansion vessel, shown in **fig.4**, MUST be fitted, and regularly maintained, to make sure the unit is not damaged by excess pressures. This may already be installed externally or internally within the thermal store (check with thermal store manufacturer).

d) Gravity fed systems (fig.5)

The shower control MUST be be fed from a cold water cistern and hot water cylinder providing nominally equal pressures. There must be a minimum of one metre head of water. The minimum head distance is measured from the base of the cold water cistern to top of the showerhead (fig.5).

e) Pumped gravity fed systems (fig.6)

The shower control can be used with a gravity fed system in conjunction with a pump to boost pressures as shown (fig.6).

There will be a minimum head requirement which will be specified in the installation and operation instructions supplied by the pump manufacturer.

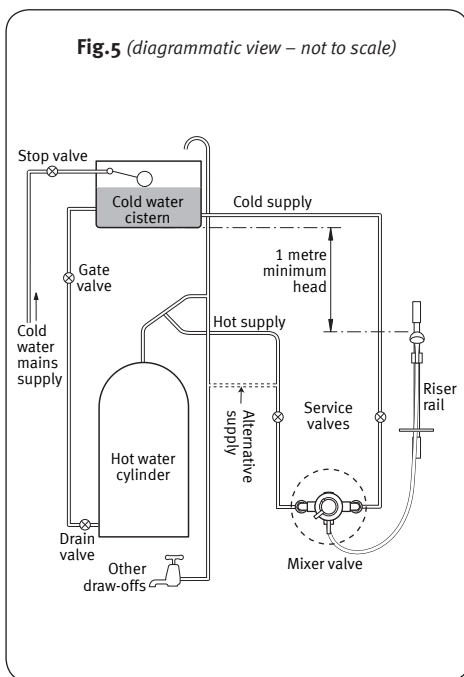
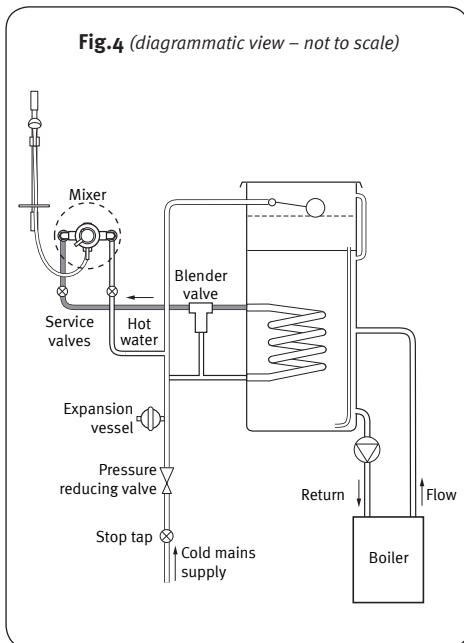
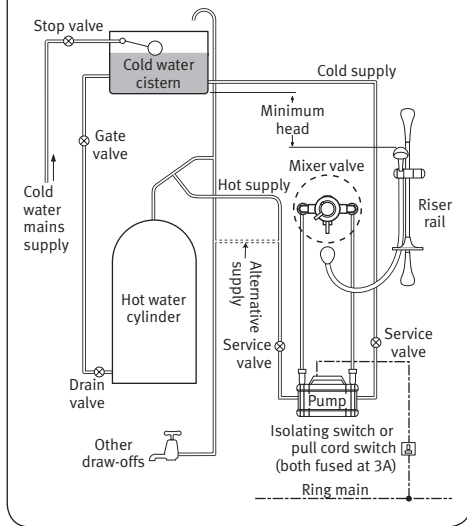

Fig.6 (diagrammatic view – not to scale)



GETTING STARTED

Check the contents to make sure all parts are present.

Before starting the installation, make sure all the openings on the mixer are carefully covered to prevent ingress of any debris, etc.

SITING OF THE SHOWER

WARNING!

The shower must not be positioned where it will be subjected to freezing conditions.

Refer to **fig.7** for correct siting of the shower.

Position the shower and showerhead on the wall so that all controls can be comfortably reached while using the shower. The showerhead and riser rail can be positioned either side of the shower.

IMPORTANT: The hot entry port is on the left-hand side of the mixer body marked by an orange label.

Fig.7 (diagrammatic view – not to scale)

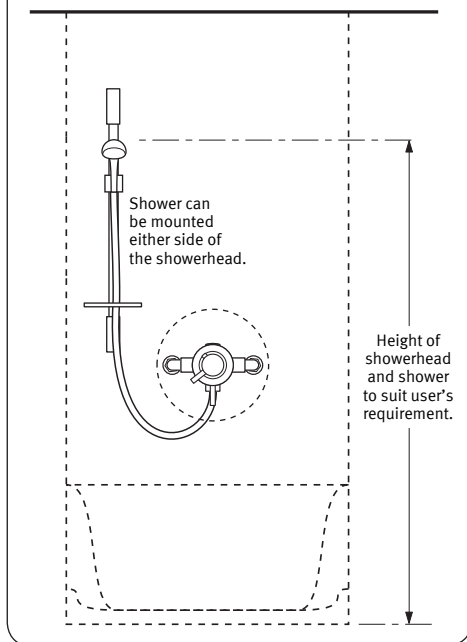

INSTALLATION

General conditions

Note: The outlet of the shower MUST NOT be connected to anything other than the hose and showerhead supplied.

DO NOT use jointing compounds on any pipe fittings for the installation.

Use only the compression fittings supplied.

DO NOT solder fittings near the mixer unit as heat can transfer along the pipework and may damage components.

Note: Suitable isolating valves (complying with Water Regulations and Bylaws) MUST be fitted on the hot and cold water supplies to the shower as an independent means of isolating the water supplies should maintenance or servicing be necessary.

When connecting pipework avoid using tight 90° elbows. Swept or formed bends will give the best performance.

IMPORTANT: The water circuit should be installed such that the flow is not significantly affected by other taps and appliances being operated elsewhere on the premises. Water pressure must not fall below specification of the shower.

Hot water pipe entry MUST be made to the left-hand side inlet (**fig.8**).

IMPORTANT: The mixer inlets contain non-removable filters that may become blocked if debris is not flushed through before fitting.

The inlet elbows allow for either rising, falling or rear entry hot and cold water supplies. The elbows have 'O' seals (**fig.9**) to the body and do not require PTFE tape or other means of sealing.

High Pressure Systems

If installing the mixer with a combi boiler or multipoint water heater with a low BTU rating, it may be necessary to insert the two flow regulators into the inlet elbows. To fit the flow regulators unscrew the inlet elbows. Insert the flow regulator into the elbow, making sure to fit the correct way (**fig.10**). Refit the elbows to the mixer.

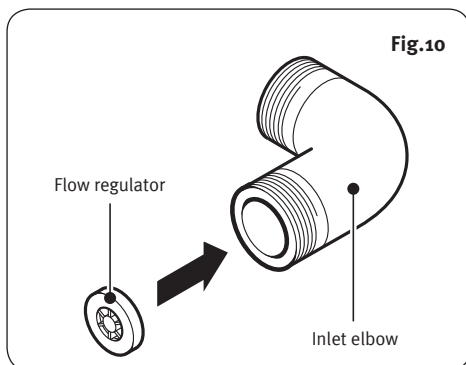
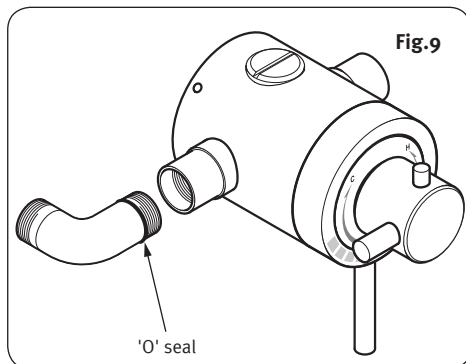
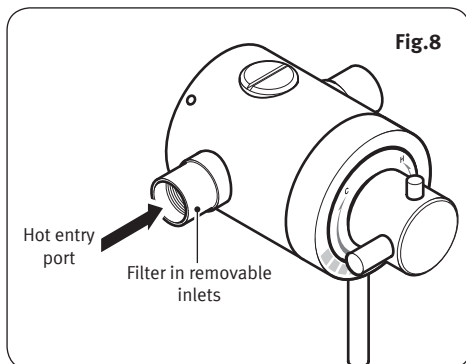

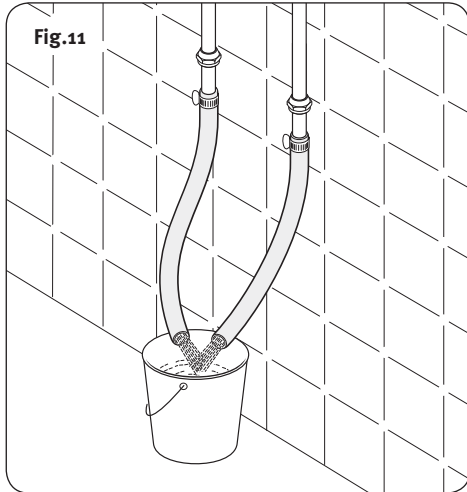

Instantaneous Gas Water Heaters

In order to provide the best performance from the shower when connected to an instantaneous water heater, the appliance must be capable of raising the temperature of the incoming water to a minimum of 52°C (125°F) and delivering a flow rate of not less than eight litres per minute.

With the flow regulators fitted and when the system is in use, the On/Off flow control should be turned fully clockwise to full flow setting.

OPTION 1: EXPOSED FITTING

Rising or falling supplies

Complete the pipework to the shower area having decided on the position of the shower and direction of pipe entry.

The final separation between pipe centres needs to be between 150 mm and 155 mm. The hot and cold water pipes should not be permanently attached to the wall within one metre of the valve to allow for final adjustment of the valve position.

Mark the position of the four locating screws for the mounting plate, although if installing to a solid brick wall using two diagonal holes will usually be enough.

Flush the pipework (**fig.11**) to clear the system of debris and check for leaks before connecting to the mixer.

Drill and plug the holes (*the wall plugs provided are suitable for most brick walls — use an appropriate masonry drill, but if the wall is plasterboard or a soft building block, use suitable wall plugs and an appropriate drill bit*).

Using the screws supplied secure the mounting plate to the wall (**fig.12**). Push fit the pipe trims onto the base of the inlet nut and then slide the nut and olive onto the supply pipes (**fig.13**).

Rear entry supplies

Using a spirit level, mark the route of incoming hot and cold water supply pipes at a distance of between 150 mm and 155 mm between centres. The hot and cold water pipes should not be permanently attached to the wall within one metre of the valve to allow for final adjustment of the valve position.

Note: Pipework installed in solid walls MUST be provided with enough free play inside a cavity to enable entry into the inlet elbows for tightening, before fixing the mixer unit to the finished wall surface.

Install the hot and cold pipework (hot pipe enters from the left), making sure that the finished pipework projects from the front face of the tiled surface of the wall by about 30 – 35 mm (**fig.14**).

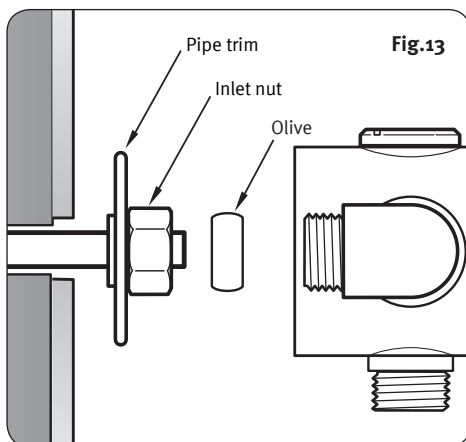
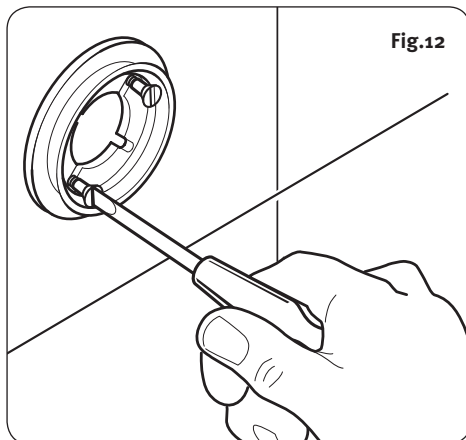

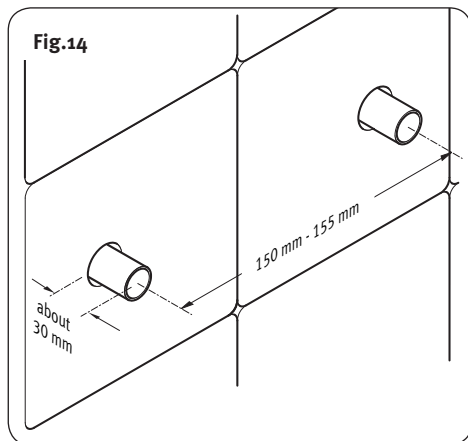

IMPORTANT: The inlets contain non-removable filters that may become blocked if debris is not flushed through before fitting.

Make good the wall and complete the tiling.

Mark the four fixing holes, although if installing to a solid brick wall using two diagonal holes will usually be enough.

Drill and plug the holes using the wall plugs provided.

Using the screws supplied secure the mounting plate to the wall (**fig.12**). Push fit the pipe trims onto the base of the inlet nut and then slide the nut and olive onto the supply pipes (**fig.13**).

Fitting the mixer

Flush the pipework to clear the system of debris and check for leaks before connecting to the mixer.

Offer the mixer to the pipework and mounting plate. Make sure that the mixer body grub screws are slack, allowing the body to move freely on the mounting plate.

Level the mixer and tighten the grub screws to secure to the mounting plate. Tighten the inlet nuts to the incoming supply pipework. Slide the trims back up to the wall.

Leak testing

Fit a hose to the outlet and direct it to waste. Turn the flow control fully clockwise to close it. Open the isolating valves to the shower. Open the flow control by turning fully clockwise and flush through.

Turn the temperature control fully anti-clockwise (HOT) and then fully clockwise (COLD).

Turn the flow control fully anti-clockwise to close off the water supply.

Check for any leaks and remedy if necessary.

TURN OFF the water supplies.

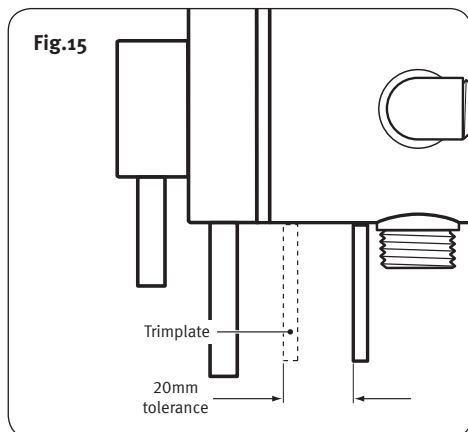

OPTION 2: BUILT-IN FITTING

Building-in depth

The allowance for varying thicknesses of tiles up to 10 mm is accommodated by the front trimplate (fig.15).

The following are typical thicknesses and are given as a guide only:

Tile	6 – 10 mm
Adhesive	2 – 3 mm
Plasterboard	9.5 – 12.5 mm
Plaster finish	2 – 3 mm

Maximum tile thickness to be 10 mm.

When installing into a stud partition or other hollow wall structure, the installer may wish to consider building rear supports or other options for fitting the mounting plate. Such options are beyond the scope of this guide.

Use the supplied tiling shroud as a template when cutting the opening for installing the shower into a solid wall, stud partition or hollow wall structure.

If using the mounting plate in a solid wall (fig.16), make sure the available building-in depth is at least 55 mm measured from the face of the wall.

Note: To ease future requirements for cleaning and servicing the unit, it is advisable to route both the incoming and outgoing pipework from the same direction.

Solid wall, hollow wall and panel mounting

The building-in depth for the mounting plate is typically 55 mm from plaster finish but this is dependant upon tile and adhesive thicknesses.

Decide upon the shower position and determine whether the hot and cold water supplies will enter from the top (falling), bottom (rising) or rear.

Note: For the rear entry supplies, in order to access the inlet elbow compression fitting (fig.17), it is advisable to have the pipework rising or falling from the elbows before routing to the rear.

Using the tiling shroud supplied, mark the hole outline position onto the wall (fig.18). Remove the plaster and brickwork (or plasterboard) to the depth required and chase out any additional areas of wall to allow for incoming pipework and access to the mixer and the outlet pipework to the

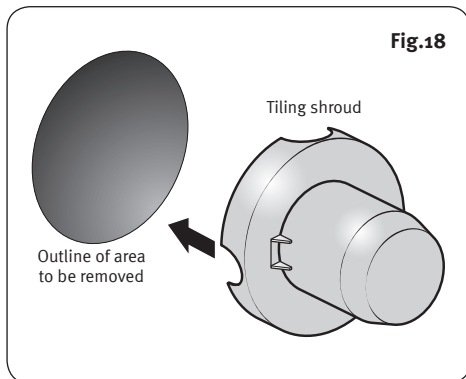
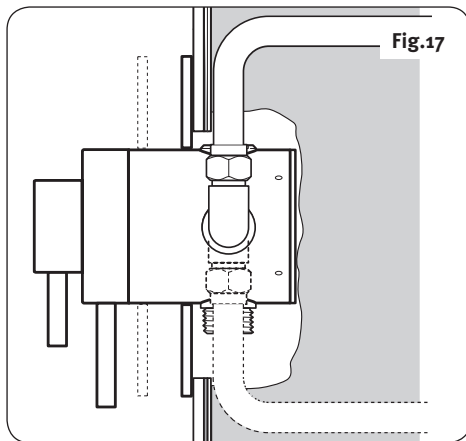
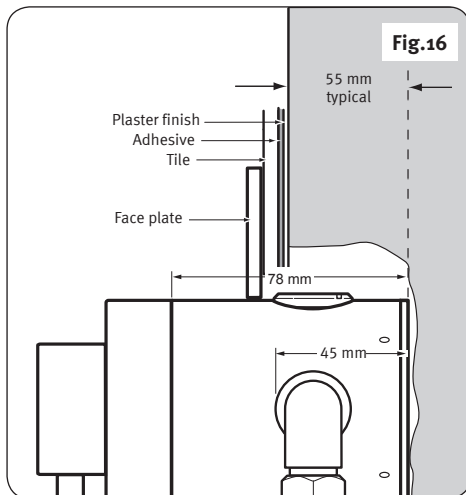

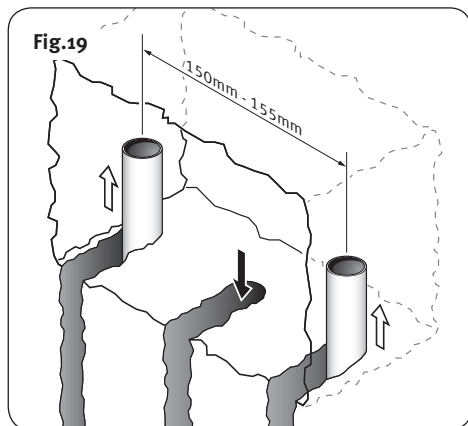

bulkhead.

The final separation between pipe centres needs to be 150 mm and 155 mm (fig.19).

Offer the mounting plate up to the recess. Centralise and mark the four holes. Drill and plug the wall (the wall plugs provided are suitable for most brick walls — use an appropriate masonry drill, but if the wall is plasterboard or a soft building block, use suitable wall plugs and an appropriate drill bit).

Note: It is preferable to flush the pipework (fig.20) to clear the system of debris and check for leaks before connecting to the mixer.

IMPORTANT: The inlet elbows contain water filters that may become blocked if debris is not flushed through before fitting.

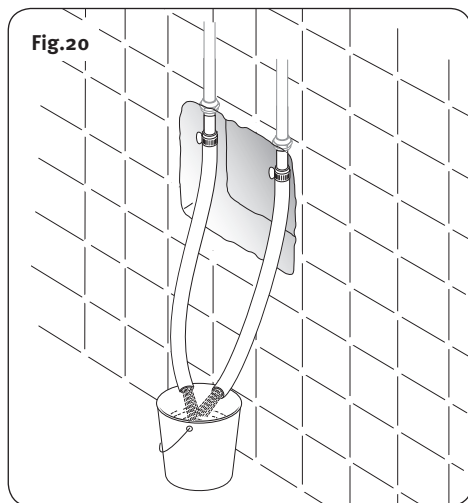

Before fitting the valve body to the pipework remove the controls:

Unscrew the temperature control lever to expose the retaining grub screw (fig.21). Using a suitable allen key unscrew the retaining screw and remove the temperature control.

Loosen the retaining screw in the base of the temperature stop (fig.22). Pull off the stop then remove the silicon ring and flow control.

Remove the plugs from the mixer valve inlets and outlet.

Make sure the inlet elbows are facing the correct way. Offer the mixer up to the mounting plate, fit and secure using the grub screws provided.

Complete the pipework to the mixer valve marking off the length to enter the elbows.

Note: Leave enough free play in the pipework to allow withdrawal from the compression fittings.

DO NOT secure the incoming pipes within one metre of the shower mixer.

Remove the mixer and cut the pipes to length. Refit the mixer to the mounting plate and pipework. Slide the inlet nut and olives onto the supply pipes.

Tighten the inlet nuts and valve body grub screws.

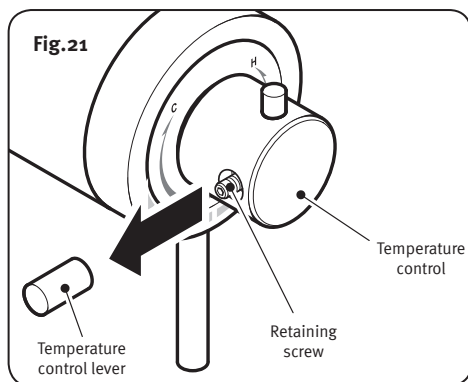

Fitting the bulkhead pipework

Complete the outlet pipework ending in a 15 mm x 1/2" BSP female thread elbow (**fig.23**).

Note: This fitting is not supplied as variations in installations require the selection of a suitable solder or compression fitting.

Screw the supplied male-thread connector into the female fitting (**fig.24**) using PTFE tape to give a watertight joint.

Note: The male-thread connector supplied has a shoulder. If fitting into a flush wall, make an extra 8 mm allowance for this shoulder at the finished surface. The connector can be cut to size if required.

The threaded connector should protrude from the finished wall surface between 8 mm and 13 mm.

Leak testing

Fit a hose to the bulkhead threaded connector and direct it to waste.

Turn the flow control fully anti-clockwise to close it. Open the isolating valves to the shower. Open the flow control by turning fully clockwise and flush through.

Turn the temperature control fully anti-clockwise (HOT) and then fully clockwise (COLD).

Turn the flow control fully anti-clockwise to close off the water supply.

Check for any leaks and remedy if necessary.

TURN OFF the water supplies.

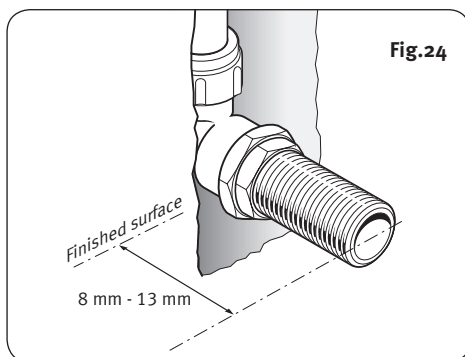
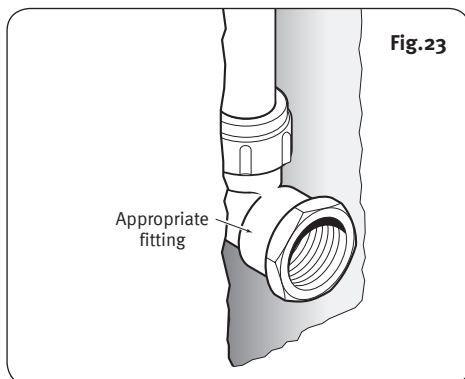
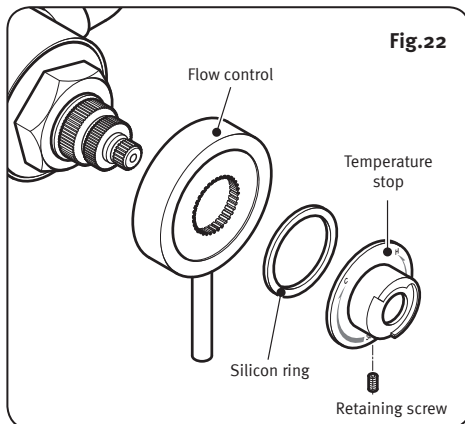

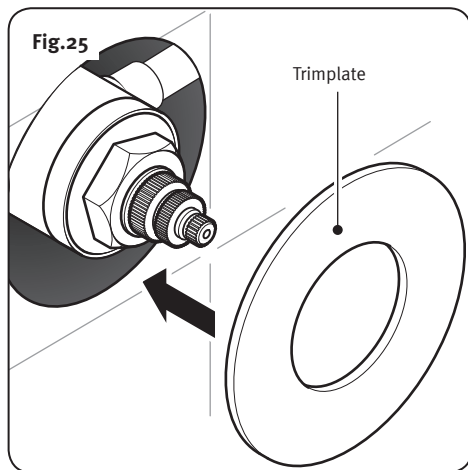

Making good

Place the tiling shroud over the shower mixer and secure temporarily. Make good the incoming and outlet pipe channelling and around the bulkhead outlet. Plaster or tile up to the edge of the shroud.

Note: The tiles must be accurately cut to match the profile of the shroud. The outer cover will then accurately seal the hole, and enable the mixer unit to be removed from the mounting bracket without the need to break any tiles.

Make sure the grout lines are flush with the tiles in order to provide a smooth sealing surface for the outer cover. When complete, remove the tiling shroud.

Fitting the trimplate

Slide the trimplate over the valve body and push up tight to the wall (**fig.25**).

Make sure the seal in the opening remains in place as it slides over the valve body. A smear of liquid soap on the seal will ease this procedure.

The trimplate incorporates a silicon sponge backing that seals against a smooth wall.

Refit the flow control, the temperature stop and the temperature control.

BULKHEAD ASSEMBLY

Screw the bulkhead elbow to the bulkhead body with the three screws supplied.

Screw the completed assembly onto the threaded connector temporarily to mark the position of the two fixing holes (**fig.26**) for securing the bulkhead to the wall.

Note: If screw thread protrudes too far out of the wall, it can be cut to the correct length using a hacksaw.

Unscrew and remove the bulkhead assembly. Check the location of the pipe in the wall before drilling.

Drill and plug the holes (*the wall plugs provided are suitable for most brick walls — use an appropriate masonry drill, but if the wall is plasterboard or soft building block, you must use suitable wall plugs and an appropriate drill bit*).

If fitting to a hollow wall structure, it may be preferable to secure the bulkhead by applying a bead of silicon seal to the back of the bulkhead.

Apply PTFE tape to the threaded connector.

Screw the bulkhead assembly onto the threaded connector until tight to the wall and the two fixing holes are aligned. Secure to the wall with the two screws supplied (**fig.27**).

Finish by clipping the cover onto the bulkhead, making sure the protruding legs locate in the bulkhead body.

At this point, refer to the 'commissioning procedure' to establish the correct maximum shower temperature.

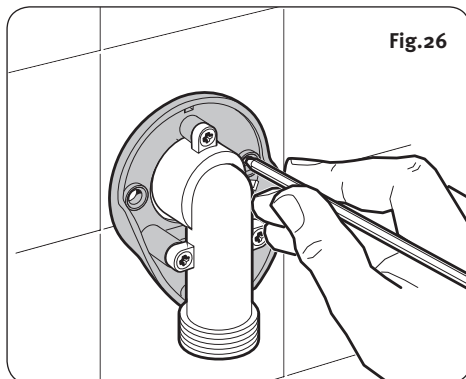

Fig.26

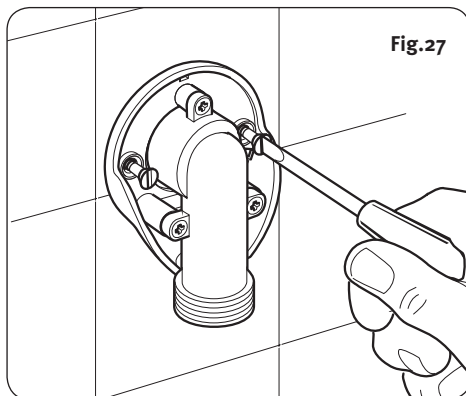
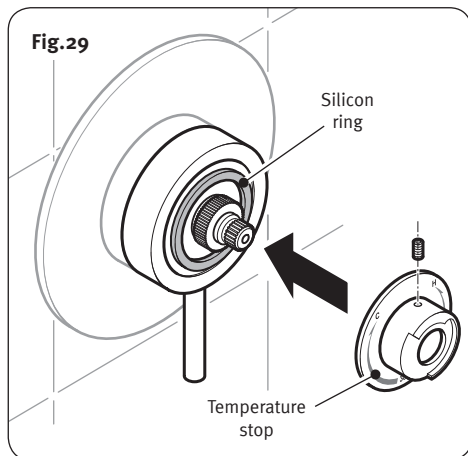
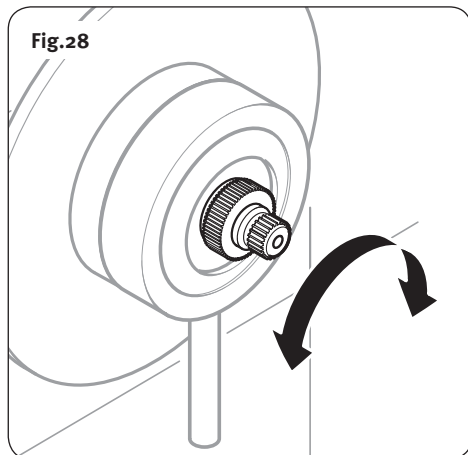

Fig.27



COMMISSIONING

IMPORTANT: Make sure that all supply pipework has been flushed through before commissioning. Make sure that both hot and cold water supplies are fully open and their design temperature and pressures and are within the requirements as stated.

Make sure the temperature control is at the maximum temperature setting, i.e. rotated fully anti-clockwise, and make sure the showerhead is directed to waste.

Start the water flow by turning the flow control clockwise. Allow the shower to run at the maximum temperature setting until the water temperature has stabilised. Rotate the temperature control anti-clockwise until the desired maximum showering temperature is reached.

The mixer has a temperature stop to prevent accidental rotation to higher temperatures. This is adjustable to provide a maximum temperature of 35°C – 45°C.

ADJUSTING THE MAXIMUM TEMPERATURE SETTING

Unscrew the temperature control lever to expose the retaining grub screw (**fig.21**). Using a suitable allen key unscrew the retaining screw and remove the temperature control.

Loosen the retaining screw in the base of the temperature stop (**fig.22**) and pull off.

Turn the flow control fully clockwise. With a steady flow running, adjust the spindle on the temperature valve by hand until the desired temperature is obtained (**fig.28**).

When you are satisfied with the temperature turn off the flow control. Refit the maximum temperature stop, taking care to align the '38°C' to the bottom of the mixer unit (**fig.29**) and secure in place.

Refit the temperature control onto the spindle. Make sure the temperature override button is aligned to 6 o'clock and then secure with the retaining screw. Screw the lever onto the retaining screw.

The mixer valve is fitted with a maximum temperature stop factory set at 38°C.

OPERATING THE SHOWER

To start the shower, turn the On/Off flow control fully clockwise for maximum flow (**fig.30**).

To stop the shower, turn the On/Off flow control fully anti-clockwise (**fig.31**).

To adjust the showering temperature rotate the temperature control — clockwise for cooler and anti-clockwise for hotter (**fig.31**).

To override the maximum temperature stop depress the button and rotate the temperature control past the stop (**fig.32**).

CAUTION: Exposed metal surfaces may become hot during use.

CLEANING

WARNING!

DO NOT use 'powerful' abrasive or solvent cleaning fluids when cleaning the shower as they may damage the plastic fittings.

DO NOT use abrasive or solvent cleaning fluids. The shower unit, riser rail, hose, etc. should be cleaned using a soft cloth and warm water.

IT IS IMPORTANT TO KEEP THE SHOWERHEAD CLEAN TO MAINTAIN THE PERFORMANCE OF THE SHOWER.

The hardness of the water will determine the frequency of cleaning. For example, if the shower is used every day in a very hard water area, it may be necessary to clean the showerhead on a weekly basis.

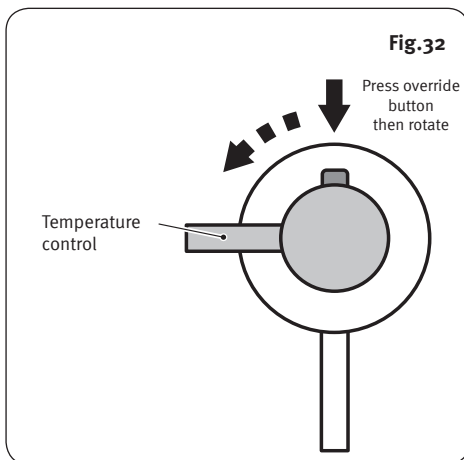
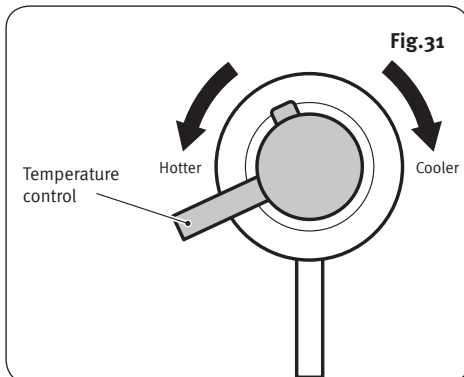
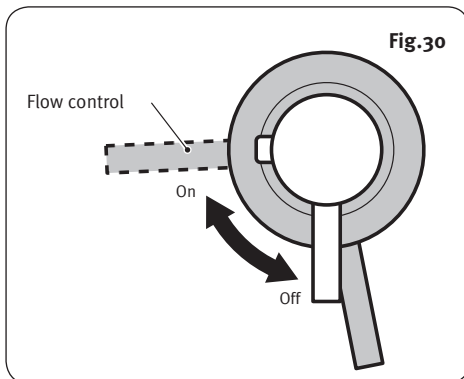

SPARE PARTS

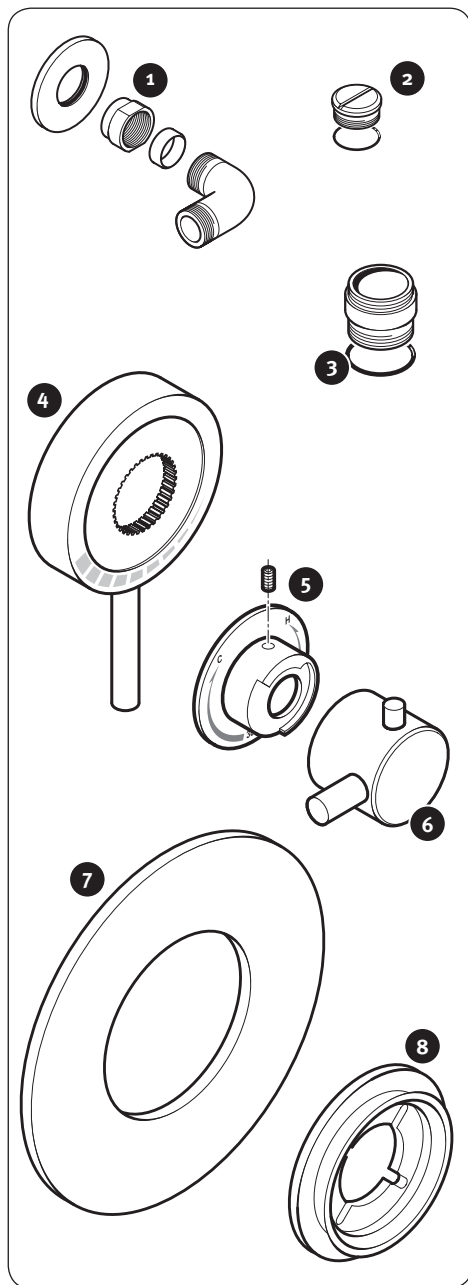

Ref.	Description	Part No.
1.	Elbow w/ cover trim	83310020
2.	Plug	83310030
3.	Outlet connector	83310040
4.	Flow control	83310410
5.	Temperature stop	83310420
6.	Temperature control	86100030
7.	Trimplate	86002000
8.	Mounting plate	83310090
-	Thermostatic cartridge	83310120
-	Check valve assembly including check valve & filter	83310130
-	Flow regulator	22011610
-	Bulkhead fitting	85500230
-	Nutted long thread connector	7032915

FAULT FINDING

The following can be carried out by a competent person

Problem/Symptom	Cause	Action/Cure
1 Water too hot.	1.1 Temperature control incorrectly commissioned.	1.1.1 Refer to 'commissioning' section.
	1.2 Not enough cold water flowing through shower.	1.2.1 Turn temperature control clockwise.
	1.3 Increase in the ambient cold water temperature.	1.3.1 Turn temperature control clockwise.
	1.4 Cold water supply blocked.	1.4.1 Turn off shower and consult a competent plumber or contact Alterna Customer Service.
	1.5 High volume of cold water drawn off elsewhere.	1.5.1 Reduce the simultaneous demand from the mains supply.
2 Water too cold.	2.1 Temperature control incorrectly commissioned	2.1.1 Refer to 'commissioning' section.
	2.2 Not enough hot water flowing through shower.	2.2.1 Turn the temperature control anti-clockwise. (Override maximum temperature stop if necessary).
	2.3 Decrease in the ambient cold water temperature.	2.3.1 Turn the temperature control anti-clockwise. (Override maximum temperature stop if necessary).
	2.4 Insufficient hot water supplies from the heating system.	2.4.1 Make sure heating appliance is set to maximum or has sufficient stored hot water. 2.4.2 Make sure heating appliance is igniting by trying a hot water tap elsewhere.
	2.5 Hot water supply blocked or restricted.	2.5.1 Turn off shower and consult a competent plumber or contact Alterna Customer Service.
	2.6 Flow regulator not fitted (HP systems only).	2.6.1 Fit the supplied flow regulators into the inlet elbows (see ' <i>instantaneous gas water heaters</i> ').
3 High water flow and/or poor performance on a mains fed system.	3.1 Flow regulators not fitted.	3.1.1 Fit the supplied flow regulators in the inlet elbows (see ' <i>high pressure systems</i> ').

FAULT FINDING

Problem/Symptom	Cause	Action/Cure
4 Water does not flow or shower pattern collapses when another outlet is turned on.	4.1 Water supplies cut off.	4.1.1 Check water elsewhere in house and if necessary contact local water company.
	4.2 Shower unit blocked.	4.2.1 Inspect the filters. Clean if necessary.
	4.3 Blockage in pipework.	4.3.1 Turn off the shower and consult a suitably competent plumber.
	4.4 Showerhead blocked.	4.4.1 Clean the showerhead.
	4.5 System not capable of supplying multiple outlets at the same time.	4.5.1 Reduce the simultaneous demand. 4.5.2 Make sure stop or service valve is fully open. 4.5.3 Check if there is sufficient water pressure.

The following is recommended for a professional qualified installer only

5 Water too cold.	5.1 Running pressure in excess of maximum recommended.	5.1.1 Fit a pressure reducing valve.
6 Shower controls noisy when in use.	6.1 Running pressure in excess of maximum recommended.	6.1.1 Fit a pressure reducing valve.
7 Shower will not shut off.	7.1 Pipework not flushed before connecting the unit (seals damaged).	7.1.1 Renew thermostatic cartridge.
	7.2 Seals damaged.	



Service Policy

In the event of a product fault or complaint occurring, the following procedure should be followed:

- 1 Telephone Customer Service on 0844 980 0749 having available, your details including post code, the model number and power rating of the product, together with the date of purchase.
- 2 Based on information given over the telephone, a Customer Service Advisor will attempt to diagnose the fault and confirm whether a site visit from a qualified service engineer is required.
- 3 All products attended to by a service engineer must be installed in full accordance with the installation guide applicable to the product. (Every product pack contains an installation guide, however, they can also be bought via our Customer Service Spares Department).
- 4 Our engineer will require local parking and if a permit is required this must be available to the engineer on arrival at the call.
- 5 It is essential that you or an appointed representative (who must be over 18 years of age) is present for the duration of the service engineer's visit. If the product is in guarantee you must produce proof of purchase.
- 6 Where a call under the terms of guarantee has been booked and the failure is not product related (i.e. scaling and furring, incorrect water pressure, pressure relief device operation or electrical/plumbing installation fault) a charge will be made. A charge will also be issued if nobody is at home when the service engineer calls or adequate parking/permit is not available.
- 7 If the product is no longer covered by the guarantee an up front fixed fee will be charged before the site visit.
- 8 Should proof of purchase not be available on an "in-guarantee" call, or should the service engineer find that the product is no longer under guarantee, the engineer will charge the same fixed price and the customer will be expected to pay the engineer before he leaves. If payment is not made on the day an administration charge will be added to the fixed charge.
- 9 If a debt is outstanding from a previous visit, or from any other purchase, we reserve the right to withhold service until the debt has been settled.
- 10 We take the health, safety and wellbeing of our employees very seriously and expects customers to treat all staff members with respect. Should any employee feel threatened or receive abuse, either verbally or physically, we reserve the right to withhold service and will support our employee with a legal prosecution.

Replacement Parts Policy

Availability: It is the policy of the manufacturer to maintain parts availability for the duration of production and a period of five years thereafter, in accordance with industry standards.

Payment should be made by credit/debit card (excluding American Express or Diners Card).

Payment can also be made by pre-payment of a pro forma invoice by cheque or money order.

STANDARD GUARANTEE

This product against all mechanical defects arising from faulty workmanship or materials for a period of five years for domestic use only, from the date of purchase, provided that it has been installed by a competent person in full accordance with the fitting instructions.

Any part found to be defective during this guarantee period we undertake to repair or replace at our option without charge so long as it has been properly maintained and operated in accordance with the operating instructions, and has not been subject to misuse or damage.

This product must not be taken apart, modified or repaired except by an authorised. This guarantee applies only to products installed within the United Kingdom and does not apply to products used commercially. This guarantee does not affect your statutory rights.

What is not covered:

- 1 Breakdown due to: **a)** use other than domestic use by you or your resident family; **b)** wilful act or neglect; **c)** any malfunction resulting from the incorrect use or quality of water or incorrect setting of controls; **d)** faulty installation.
- 2 Repair costs for damage caused by foreign objects or substances.
- 3 Total loss of the product due to non-availability of parts.
- 4 Compensation for loss of use of the product or consequential loss of any kind.
- 5 Call out charges where no fault has been found with the appliance.
- 6 The cost of repair or replacement of showerheads, hoses, riser rails and/or wall brackets or any other accessories installed at the same time.
- 7 The cost of routine maintenance, adjustments, overhaul modifications or loss or damage arising therefrom, including the cost of repairing damage, breakdown, malfunction caused by corrosion, furring, pipe scaling, limescale, system debris or frost.

Distributed in the UK for Jewson Limited

Aldwych House

81 Aldwych

London

WC2B 4HQ.

Registered in England & Wales No. 348047

Customer Service: ☎ 0844 980 0749

Trade Installer Hotline: ☎ 0844 980 0748

Fax: 0844 980 0744