

TRITON

T150+

electric shower

**REGISTER ONLINE
ENTER A PRIZE DRAW**

**WIN
£100**

LOVE2SHOP VOUCHERS

VISIT OUR WEBSITE TODAY

TRITONSHOWERS.CO.UK/REGISTER

*PRODUCT REGISTRATION IS ONLY AVAILABLE
TO UNITS PURCHASED & INSTALLED IN THE UK*



FOR YOUR SERVICE REFERENCE

NOTE DOWN THE PRODUCT CODE BELOW
(FROM THE FRONT OR TOP OF THE BOX)



ALTERNATIVELY REGISTER BY TEL: 024 7637 8321

IMPORTANT SAFETY ADVICE

The shower unit **MUST BE** switched off at the isolating switch when not in use. This is a safety procedure recommended for all electrical appliances.

The showerhead and hose supplied with this product are a safety critical part of your shower. Failure to use genuine Triton parts may cause injury and invalidate your guarantee.

INSTALLATION AND OPERATING INSTRUCTIONS













Please read this book thoroughly and familiarise yourself with all instructions before commencing installation and keep it for future reference.

The shower installation **MUST** be carried out by a suitably qualified person, **in the sequence of this instruction book.**



PLEASE READ THIS IMPORTANT SAFETY INFORMATION

Products manufactured by Triton are safe and without risk, provided they are installed, used and maintained in good working order in accordance with our instructions and recommendations.

-  **WARNING: DO NOT** operate the shower if there is a possibility of water within the heater or pipes feeding the shower of being frozen.
-  **DO NOT** operate the unit if the showerhead or spray hose becomes damaged.
-  **DO NOT** restrict flow out of shower by placing showerhead in direct contact with your body.
-  **DO NOT** operate the shower if water ceases to flow during use or if water has entered inside the unit because of an incorrectly fitted cover.
-  **WARNING: If restarting the shower immediately after stopping, be aware that a slug of hot water will be expelled for the first few seconds.**
-  The spray head must be descaled regularly.
-  Fit only shower heads recommended by the manufacturer and never fit any additional device to restrict the water outlet flow.
-  The outlet must not be connected to any tap or fitting other than those specified.
-  This appliance is intended to be permanently connected to the water mains and not connected by a hose set.
-  The water inlet of this appliance shall not be connected to inlet water obtained from any other water heating system.
-  **WARNING:** This appliance is not to be used for a potable water supply.
-  A suitable double pole isolation switch for supply disconnections must be incorporated in the fixed wiring circuit in accordance with current wiring rules. See Electrical Installation section for further details.
-  Mains water pressure only.
Minimum inlet pressure 100kPa (1 bar)
Maximum inlet pressure 1000kPa (10 bar)

This book contains all the necessary fitting and operating instructions for your electric shower.

Care taken during the installation will provide a long, trouble-free life from your shower.

▲ WARNING ▲

This appliance can be used by children aged from 3 years and above and persons with reduced physical, sensory or mental capabilities or lack of experience and knowledge if they have been given supervision or instruction concerning use of the appliance in a safe way and understand the hazards involved. Children may not play with the appliance. Cleaning and user maintenance shall not be made by children.



IMPORTANT - PLEASE READ THESE GENERAL GUIDANCE NOTES BEFORE PROCEEDING



1 GENERAL

- 1.1 Isolate the electrical and water supplies before removing the cover.
- 1.2 Read all of these instructions and retain them for later use.
- 1.3 **DO NOT** take risks with plumbing or electrical equipment.
- 1.4 Isolate electrical and water supplies before proceeding with the installation.
- 1.5 The unit must be mounted onto the finished wall surface (on top of the tiles). **DO NOT** tile up to or seal around **ANY PART** of the unit using silicone sealer after fixing to the wall. Special care must be taken **NOT TO BLOCK OR SEAL ANY PRD VENTS ON THE UNIT**.
- 1.6 Contact Customer Experience (*see back page*), if any of the following occur:
 - a) *If it is intended to operate the shower at pressures above the maximum or below the minimum stated.*
 - b) *If the unit shows a distinct change in performance.*
 - c) *If the shower is frozen.*
- 1.7 If it is intended to operate the shower in areas of hard water (above 200 ppm temporary hardness), a scale inhibitor may have to be fitted. For advice on the Scale Inhibitor, contact Customer Experience.
- 1.8 The showerhead must be cleaned regularly with descaler to remove scale and debris, otherwise restrictions to the flow on the outlet of the unit will result in higher temperatures and could also cause the (PRD) Pressure Relief Device in the unit to operate.
- 1.9 This product is not suitable for mounting into steam rooms or steam cubicles.

2 PLUMBING

- 2.1 The plumbing installation must comply with Water Regulations, Building Regulations or any particular regulations as specified by Local Water Company or Water Undertakers and should be in accordance with BS EN 806.
- 2.2 The supply pipe must be flushed to clear debris before connecting to the shower unit.

- 2.3 **DO NOT** solder pipes or fittings within 300mm of the shower unit, as heat can transfer along the pipework and damage components.
- 2.4 **DO NOT** fit any form of outlet flow control as the outlet acts as a vent for the heater can.
- 2.5 **DO NOT** use excessive force when making connections to the flexible hose or showerhead, finger tight is sufficient.
- 2.6 All plumbing connections must be completed before making the electrical connections.
- 2.7 This appliance **MUST NOT** be connected to the inlet supply by a hose-set.

3 ELECTRICAL

- 3.1 The installation must comply with BS 7671 'Requirements for electrical installations' (IEE wiring regulations), building regulations or any particular regulations as specified by the local Electrical Supply Company.
- 3.2 This appliance **MUST** be earthed.
- 3.3 In accordance with 'The Plugs and Sockets etc. (Safety) Regulations 1994', this appliance is intended to be permanently connected to the fixed wiring of the electrical mains system.
- 3.4 Make sure all electrical connections are tight to prevent overheating.
- 3.5 A 30mA residual current device (RCD) **MUST** be installed in all UK electric and pumped shower circuits. This may be part of the consumer unit or a separate unit.
- 3.6 Switch off immediately at isolating switch if water ceases to flow during use.
- 3.7 Other electrical equipment i.e. extractor fans, pumps must not be connected to the circuits within the unit.

3.8 Switch off at isolating switch when not in use. This is a safety procedure recommended with all electrical appliances.

- 3.9 As with all electrical appliances it is recommended to have the shower and installation checked at least every two years by a competent electrician to ensure there is no deterioration due to age and usage.

INTRODUCTION

This book contains all the necessary fitting and operating instructions for your Triton electric shower.

Take time to read this book thoroughly and familiarise yourself with all instructions before commencing installation. Please keep it for future reference.

The shower installation must be carried out by a suitably qualified person and in the sequence of this instruction book.

Care taken during the installation will provide a long, trouble-free life from your shower.

SPECIFICATIONS

Electrical

Nominal power rating at 240V	Nominal power rating at 230V
8.5kW – (40A MCB rating)	7.8kW – (40A MCB rating)
9.5kW – (40A MCB rating)	8.7kW – (40A MCB rating)

Water

Inlet connection – 15 mm diameter.

Outlet connection – ½" BSP male thread.

Entry Points

Water – **Right:** Top, bottom back, bottom.

Cable – **Right:** Top, bottom back, bottom.

Left: Top

Materials

Backplate, cover, controls, showerhead – ABS.

Sprayplate – Acetal.

Elements – Minerally insulated corrosion resistant metal sheathing.

Dimensions

Height – 361 mm

Width – 245 mm

Depth – 121 mm

Standards and Approvals

Splashproof rating IP25.

Complies with the requirements of current British and European safety standards for household and similar electrical appliances.

Complies with requirements of the British Electrotechnical Approvals Board (BEAB) and BEAB CARE mark (BEAB).

ADVICE TO USERS

Important: When first installed the unit will be empty. It is essential the unit should contain water before the elements are switched on. It is vital that the commissioning procedure is followed. Failure to carry out this operation will result in damage to the unit and will invalidate the guarantee.

The following points will help you understand how the shower operates:

a) Temperature/flow rate

The temperature/flow control can be adjusted to provide shower temperatures between 35°C and 47°C.

Alternatively, adjusting a temperature stop mechanism inside the unit to 41°C or 43°C maximum can restrict the shower temperature.

Important: To comply with BEAB care mark requirements the unit must not be able to run hotter than 41°C (this is used in healthcare or special needs environments). The **T150 + thermostatic** unit is factory set at 47°C (see page 27) on how to adjust the **MAXIMUM temperature stop** to 41°C

At a selected showering temperature the unit will provide the optimum flow rate possible. Note the maximum flow rate for the given temperature will be greater in the summer than in the winter because of the variance in the ambient mains water supply.

Should water pressure/flow to the shower be insufficient for optimum performance then the unit will operate at a reduced power level and provide the highest flow rate possible for the given shower temperature.

b) Temperature stabilisation

The shower will maintain temperature in accordance with the BEAB care mark.

If ever the water becomes too hot, and you cannot obtain cooler water, first check that the sprayplate in the showerhead has not become blocked.

DO NOT place items such as soap or shampoo bottles on top of the unit. Liquid could seep through the joint between the cover and backplate, and possibly damage the sealing rubber.

PLEASE USE THE FOLLOWING CHECK LIST TO AID YOUR INSTALLATION

	Tick off as you complete
SECTION 1 1 Product specifications	<input type="checkbox"/> 1
SECTION 2 2 Product entry points and dimensions.....	<input type="checkbox"/> 2
SECTION 3 3 Check that the electric supply will satisfy requirements	<input type="checkbox"/> 3
SECTION 4 4 Siting of the shower.....	<input type="checkbox"/> 4
SECTION 5 5 Plumbing installation	<input type="checkbox"/> 5
SECTION 6 6 Electrical installation and pumps	<input type="checkbox"/> 6
SECTION 7 7 Fitting the inlet trims	<input type="checkbox"/> 7
SECTION 8 8 Commissioning temperature, DIP switch settings and fitting the cover	<input type="checkbox"/> 8
SECTION 9 9 Familiarise yourself with the user operating instructions	<input type="checkbox"/> 9



Please read this book thoroughly and familiarise yourself with all instructions before commencing installation and keep it for future reference.

The shower installation **MUST** be carried out by a suitably qualified person, **in the sequence of this instruction book.**

To check the product suitability for commercial and multiple installations, please contact Triton's specification advisory service before installation. Please see back of book for contact information.

Contents	Page
IMPORTANT SAFETY INFORMATION AND INTRODUCTION	2 - 3
General advice to users	4
Installation checklist.....	5
Main components	7 - 8
Specifications.....	9
Dimensions & entry points	10
Electrical requirements.....	11 - 12
Siting of the shower.....	13 - 14
Plumbing installation	16 - 17
Electrical installation and pumps.....	18 - 21
Fitting the inlet trims	22
Commissioning.....	23
Fitting the cover	24
Adjusting the Maximum temperature stop	
35°C to 47°C - Standard showering	25- 26
BEAB Care (41°C).....	27
PCB Dip Switch settings.....	28
Operating instructions and functions	29
Instructions for installers and service engineers only.....	30
Fault finding	31 - 33
In-service Testing	34 - 36
Spare parts	37
UK Service policy /Guarantee, etc	Rear cover

PRODUCT FICHE

Model	8.5kW	9.5kW
Load Profile	XS	XS
Energy Efficiency Class	A	A
Energy Efficiency (%)	39	39
Annual Electricity Consumption (kwh)	482	483
Sound Power Level (db)	15	15

MAIN COMPONENTS

Inside the unit (Fig.A)

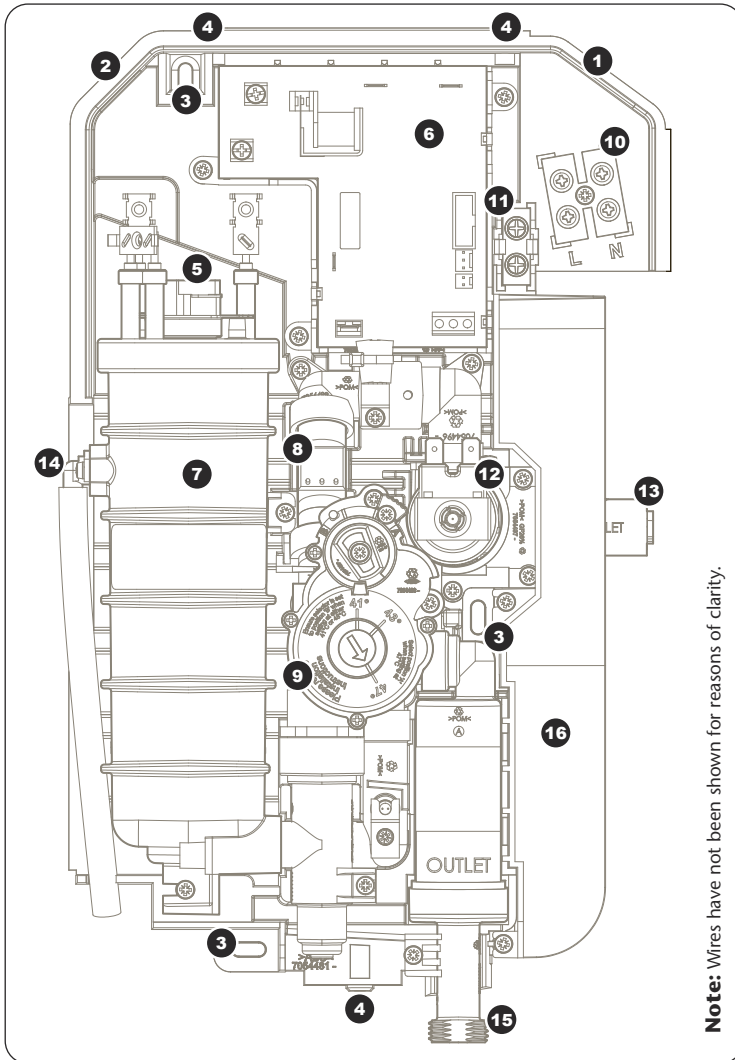

Note: Wires have not been shown for reasons of clarity.

Inside the unit (Fig.A)

- | | | |
|---|--|---|
| <p>1. Top cable and pipe entry</p> <p>2. Top left cable entry</p> <p>3. Wall screw fixings</p> <p>4. Cover screw fixings</p> <p>5. Thermal safety cut-out</p> <p>6. Power printed circuit board</p> | <p>7. Can and element assembly</p> <p>8. Flow sensor</p> <p>9. Thermostatic valve & maximum temperature selector</p> <p>10. Terminal block (L & N)</p> <p>11. Earth connection</p> <p>12. Solenoid valve</p> | <p>13. Water inlet</p> <p>14. Pressure relief device (PRD)</p> <p>15. Shower outlet</p> <p>16. Splash guard</p> |
|---|--|---|

MAIN COMPONENTS (CONTINUED)

Inside cover (Fig.B)

- 16. Stop/start printed circuit board
- 17. Control printed circuit board

Other items

- Instructions, guarantee, etc.

Inside cover (Fig.B)

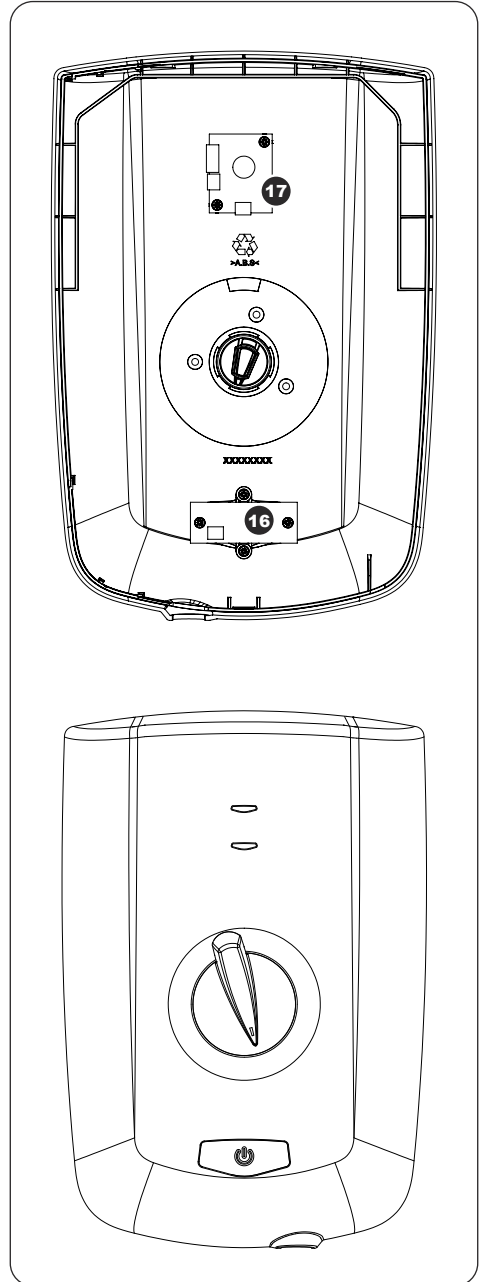

ELECTRICAL	
Nominal power - rating at 240V	Nominal power - rating at 230V
8.5kW – (40A MCB rating)	7.8kW – (40A MCB rating)
9.5kW – (40A MCB rating)	8.7kW – (40A MCB rating)
PLUMBING (see page 13 & 14 for water requirements)	
Supply Source	Mains pressure cold water only
Minimum running pressure and flow to the inlet of the shower	50kPa (0.5 bar) at 8 litres per minute for 8.5kW & 9.5kW
Maximum static pressure	1000 kPa (10 bar)
Maximum inlet temperature	28°C
Minimum inlet temperature	2°C
Inlet connection	15mm diameter
Outlet connection	½" BSP male thread
MATERIALS	
ABS	Backplate, cover, controls, showerhead
Minerally insulated corrosion resistant metal sheathing	Elements
STANDARDS and APPROVALS	
Splashproof rating	IP25
Safety	Complies with the requirements of current British and European safety standards for household and similar electrical appliances
BEAB	Complies with the requirements of the BEAB Care mark
CE	Meets with Compliance with European Community Directives (CE)

Fig.1

DIMENSIONS

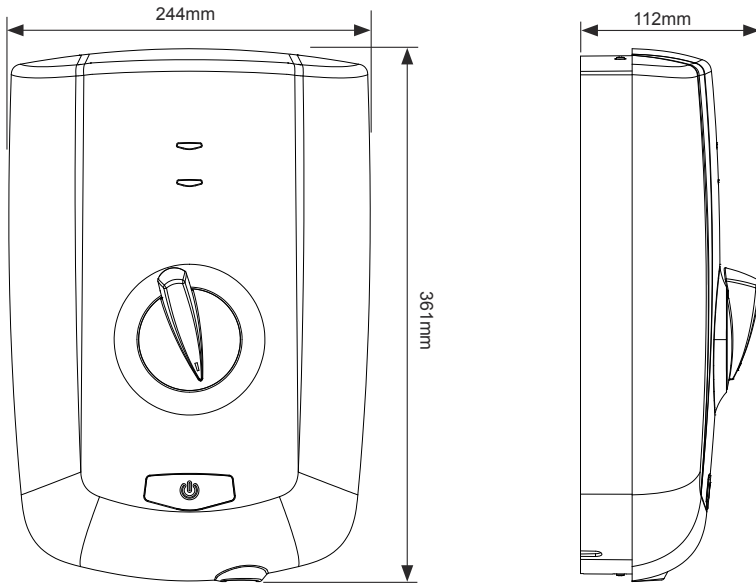

Fig.2

ENTRY POINTS

Diagram Key:



Water Entry Points



Cable Entry Points

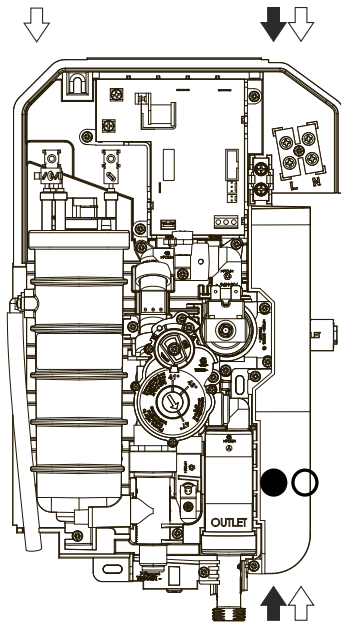

ELECTRICAL REQUIREMENTS

⚠ WARNING! ⚠
THIS APPLIANCE MUST BE EARTHED

The installation, supply cable and circuit protection must conform with BS 7671 (IEE wiring regulations) and be sufficient for the amperage required.

The following notes are for guidance only:

- 1** The shower must only be connected to a 230-240V ac supply. If you are installing a shower with a kilowatt rating above 9kW, it is advisable to contact the local electricity supply company.
- 1.1** The electrical rating of the shower is shown on the rating label (**Fig.3**) within the unit.
- 2** Before making any sort of electrical connection within the installation make sure that no terminal is live. If in any doubt, switch off the whole installation at the mains supply and remove the correct fuse.
- 3** The shower must be connected to its own independent electrical circuit. **IT MUST NOT** be connected to a ring main, spur, socket outlet, lighting circuit or cooker circuit.
- 3.1** The electrical supply must be adequate for the loading of the unit and existing circuits.
- 4** Check your consumer unit (main fuse box) has a main switch rating of 80A or above and that it has a spare fuse way which will take the fuse or Miniature Circuit Breaker (MCB) necessary for the shower (**Fig.4**).
- 4.1** If your consumer unit has a rating below 80A or if there is no spare fuse way, then the installation will not be straightforward and may require a new consumer unit serving the house or just the shower.
- 4.2** You will need to contact the local electricity company. They will check the supply and carry out what is necessary.
- 5** For close circuit protection **DO NOT** use a rewirable fuse. Instead use a suitably rated Miniature Circuit Breaker (MCB) or cartridge fuse (**see Table A**).
- 5.1** A 30mA residual current device (RCD) **MUST** be installed in all UK electric and pumped shower circuits. This may be part of the consumer unit or a separate unit.

Fig.3



Fig.4 Schematic of installation circuit

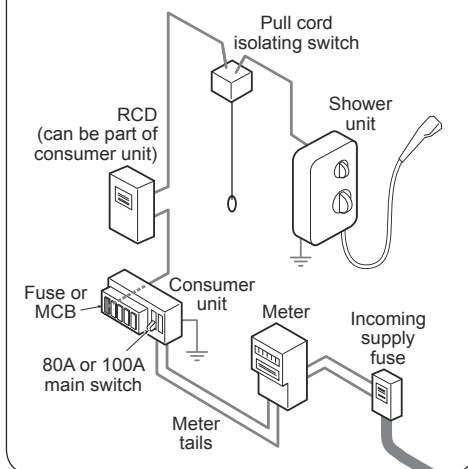

Table A

CIRCUIT PROTECTION		
unit rating	MCB	cartridge fuse
7.0kW	30/32A	30A
7.5kW	32A	35A
8.0kW	40A	35A
8.5kW	40A	45A
9.0kW	40A	45A
9.5kW	40/45A	45A
10.5kW	45A	45A

- 6 A 45 amp double pole isolating switch with a minimum contact gap of 3mm in both poles must be incorporated in the circuit.
- 6.1 It must have a mechanical indicator showing when the switch is in the OFF position, and the wiring must be connected to the switch without the use of a plug or socket outlet.
- 6.2 The switch must be accessible and clearly identifiable, but out of reach of a person using a fixed bath or shower, except for the cord of a cord operated switch, and should be placed so that it is not possible to touch the switch body while standing in a bath or shower cubicle. It should be readily accessible to switch off after using the shower.
- 7 Where shower cubicles are located in any rooms other than bathrooms, all socket outlets in those rooms must be protected by a 30mA RCD.
- 8 The current carrying capacity of the cable must be at least that of the shower circuit protection (see Table B).
- 8.1 To obtain full advantage of the power provided by the shower, use the shortest cable route possible from the consumer unit to the shower.
- 8.2 It is also necessary to satisfy the disconnection time and thermal constraints which means that for any given combination of current demand, voltage drop and cable size, there is a maximum permissible circuit length.
- 9 The shower circuit should be separated from other circuits by at least twice the diameter of the cable or conduit.
- 9.1 The current rating will be reduced if the cabling is bunched with others, surrounded by thermal loft or wall insulation or placed in areas where the ambient temperature is above 30°C. Under these conditions, derating factors apply and it is necessary to select a larger cable size.
- 9.2 In the majority of installations (see Table B), the cable will unavoidably be placed in one or more of the above conditions. This being so, it is strongly recommended to use a minimum of 10mm cabling throughout the shower installation.

- 9.3 In any event, it is essential that individual site conditions are assessed by a competent electrician in order to determine the correct cable size and permissible circuit length.

Table B

Twin and earth PVC insulated cable Current carrying capacity		
Installed in an insulated wall	In conduit trunking	Clipped direct or buried in a non-insulated wall
6mm ² 32A	6mm ² 38A	6mm ² 46A
10mm ² 43A	10mm ² 52A	10mm ² 63A
16mm ² 57A	16mm ² 69A	16mm ² 85A

Note: Cable selection is dependent on derating factors

***The method below may be used by installers to determine the approximate size of the incoming cable.**

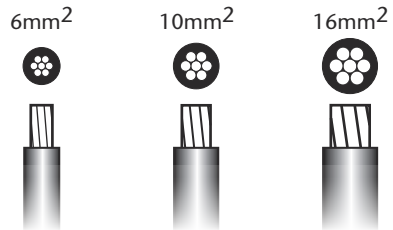

1. Measure the width of an individual strand, and half that measurement to find (r) , e.g: $1.34\text{mm} \div 2 = (r) 0.67\text{mm}$
2. Multiply $(r) \times (r) \times 3.14$, e.g: $(r) 0.67 \times (r) 0.67 \times 3.14 = 1.41\text{mm}^2$
3. Multiply this by the number of wire strands (usually 7), e.g: $1.41\text{mm}^2 \times 7 = 9.87\text{mm}^2$.
4. The number obtained would suggest 10mm^2 wiring.

***PLEASE NOTE:** If unsure, consult a qualified Electrician.

Water Requirements

The installation must be in accordance with Water Regulations/Bylaws.

Supply Source.....	Mains pressure cold water only
Minimum running pressure and flow at the shower inlet*	50kPa (0.5 bar) at 8 litres per minute*
Maximum static pressure	1000 kPa (10 bar)
Maximum inlet temperature	28°C (BEAB Care mark 20°C)
Minimum inlet temperature	2°C (BEAB Care mark 5°C)

* Recommended minimum running pressure and flow at the shower inlet 100kPa (1 bar) at 8 litres per minute for full performance.

Note: if the recommended running pressure and flow is not available there will be a noticeable reduction in flow from the showerhead.

If it is intended to operate the shower at pressures above the maximum or below the minimum stated, contact Customer Experience for advice.

Fig.5 shows a typical system layout.

Do not use jointing compounds on any pipe fittings for the installation.

Important: To comply with BEAB care mark in service testing procedure the isolating valve should be located close to the shower unit.

Important: The unit must be mounted on a flat surface which covers the full width and length of the backplate. It is important that the wall surface is flat otherwise difficulty may be encountered when fitting the cover and subsequent operation of the unit may be impaired.

Fig.5 Diagrammatic view (not to scale)

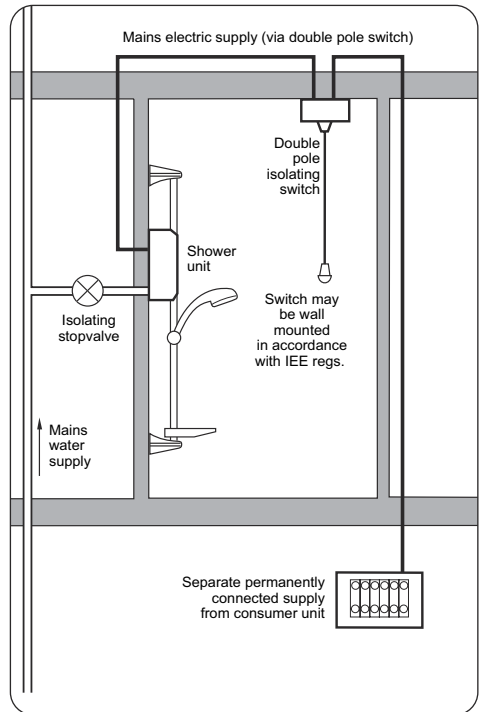

Siting of The Shower - New installation

For ease of servicing, the unit must always be mounted on the surface of tiled walls. Never tile up to the unit.

Refer to **Fig.6** for correct siting of shower. Position the unit where it will not be in direct contact with water from the showerhead. Position the shower unit vertically.

Allow enough room between the ceiling and the shower to access the cover top screws.

Siting of the shower - As a replacement of other showers

If replacing an old shower then depending on pipe and cable positions the original top or bottom wall fixing screw hole may be exposed. A white and satin chrome colour screw cap is supplied that can be used to conceal the existing screw fixing as an alternative to using silicon sealant (**Fig.7**).

IMPORTANT: Water regulations

It is required that the showerhead be 'constrained by a fixed or sliding attachment so that it can only discharge water at a point not less than 25mm above the spill-over level of the relevant bath, shower tray or other fixed appliance'.

If the riser kit is supplied with a 'soapdish hose retainer' or bespoke 'hose retainer', it will in most cases meet this requirement. If the showerhead can still be placed within a bath, basin or shower tray within the 25mm limit, then a double check valve or similar **MUST be fitted in the supply pipework to prevent back-flow**.



WARNING



The shower **MUST NOT** be positioned where it will be subjected to freezing conditions.

Fig.6 Diagrammatic view (not to scale)

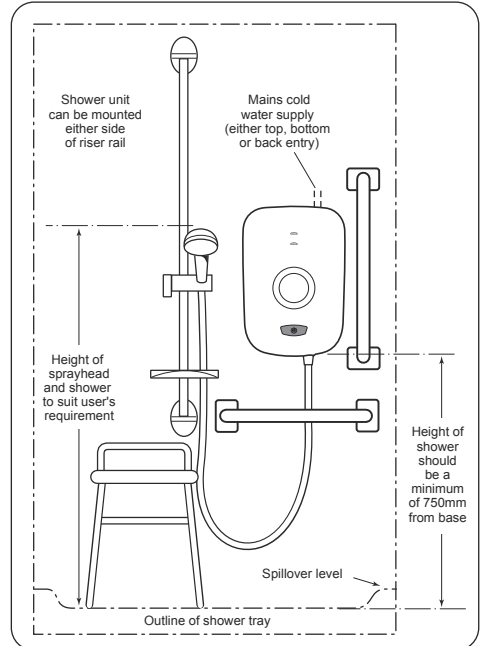
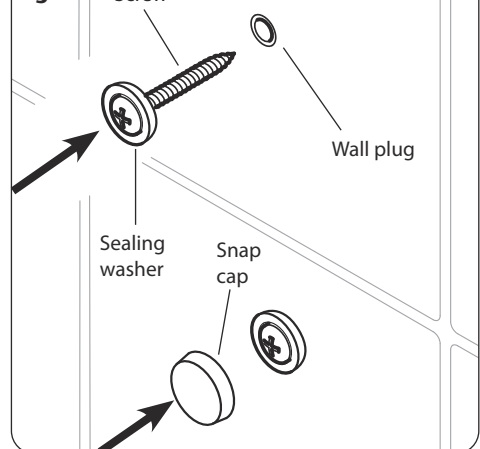

Fig.7



Pressure relief safety device

A pressure relief device (PRD) is designed into the shower unit which complies with European standards. The PRD provides a level of appliance protection should an excessive build up of pressure occur within the shower.

Do not operate the shower with a damaged or kinked shower hose, or a blocked showerhead which can cause the PRD to operate.

When commissioning, the showerhead must be removed from the flexible hose. Failure to follow this procedure may also cause the PRD to operate.

Make sure the shower is positioned over a bath or shower tray because if the PRD operates, then water will eject from the bottom of the unit.

Should this happen, turn off the electricity and water supplies to the shower at the isolating switch and stop valve. Contact Customer Experience for advice on replacing the PRD.

IMPORTANT PRD INFORMATION

DO NOT seal the outlet hole on the bottom left of the backplate.
This is the PRD escape vent.

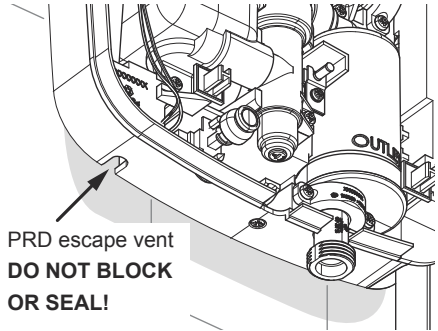

Plumbing Connections

Plumbing to be carried out before wiring

DO NOT use jointing compounds on any pipe fittings for the installation.

DO NOT solder fittings near the shower unit as heat can travel along pipework and damage components.

A compression or demountable push-fit fitting can be used to connect to the shower inlet.

Note: Do not use a push-fit fitting that does not allow the inlet to be disconnected for servicing i.e. a non-demountable push-fit fitting.

Note: An additional stop valve (complying with Water Regulations) **Must** be fitted in the mains water supply to the shower as an independent means of isolating the water in order to carry out maintenance or servicing. If this isolator is fitted in a loft space, the loft must have a fixed access ladder and be boarded, with appropriate lighting from the access point to the isolator.

Important: Before completing the connection of the water supply to the inlet of the shower, flush out the pipework to remove all swarf and system debris. This can be achieved by connecting a hose to the pipework and turning on the mains water supply long enough to clear the debris to waste.

Fitting Procedure

- Turn off water supply either at the mains stop valve or the isolating stop valve.
- Temporarily connect the mains water supply to the inlet of the shower using a 15mm x 15mm fitting.
- Use the backplate as a template making sure it is level and mark the fixing holes. The top and one of the bottom two fixing holes should be sufficient to hold the shower.
- Remove the unit from the wall. Drill and plug the wall. An appropriate drill bit should be used. If the wall is plasterboard or a soft building block, appropriate wall plugs should be fitted.

Fig.8

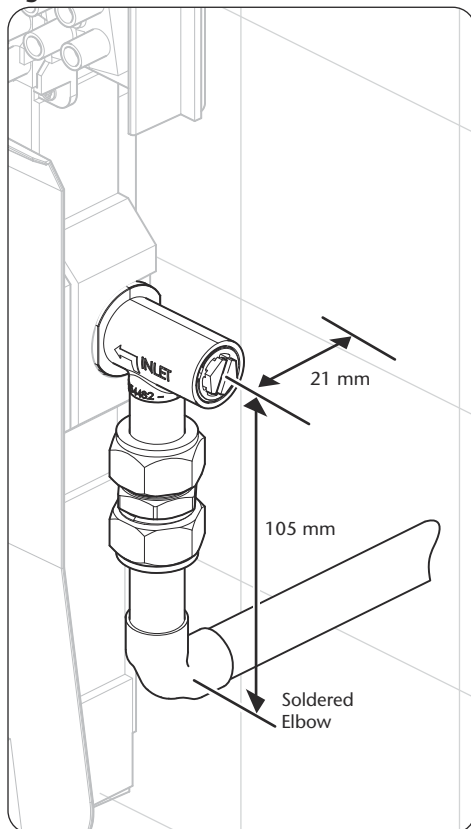

- Screw the top fixing screw into position leaving the base of the screw head protruding 6mm out from the wall.

Note: If installing a feed pipe from the back, the use of a soldered Elbow connector is recommended. It should be positioned approximately 105 mm from the inlet connector centre. The centre of the inlet valve to the wall surface is 21 mm.

The inlet fitting is designed to rotate through 180° to allow for either Top or Bottom/Rear entry fitting (**Fig.9**).

DO NOT use excessive force when making these connections.

Make sure the backplate is square on the wall and tighten the retaining screws which hold it to the wall.

Turn on mains water supply and check for leaks in pipework connection to the shower.

Note: At this stage no water can flow through the unit.

Important: Using a suitable sealant, always seal around the rear entry pipework to prevent water entering the wall.

Important: The Inlet Fitting Must be used in the Bottom fitting position for Rear fitting. Under NO circumstances must the Inlet be rotated 90° and the pipe fitted directly. The shower has not been designed for this method of connection. See below.

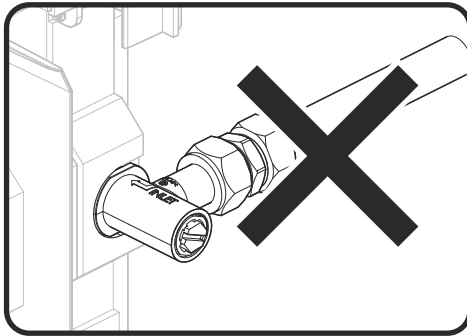

Warning!

The outlet of the shower acts as a vent and must not be connected to anything other than the hose and showerhead supplied.

Fig.9

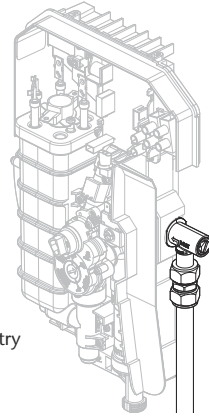

A. Bottom Entry

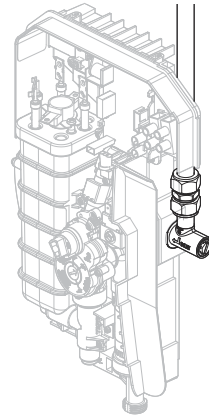

B. Top Entry

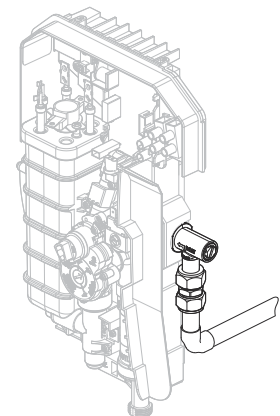

C. Rear Entry

Cable Routing Options

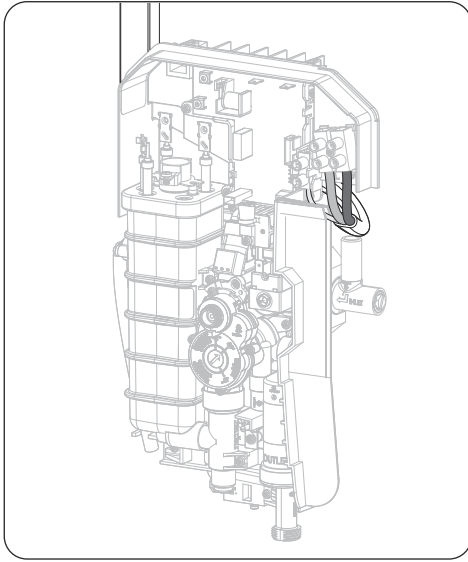

A. Top Left Cable Entry

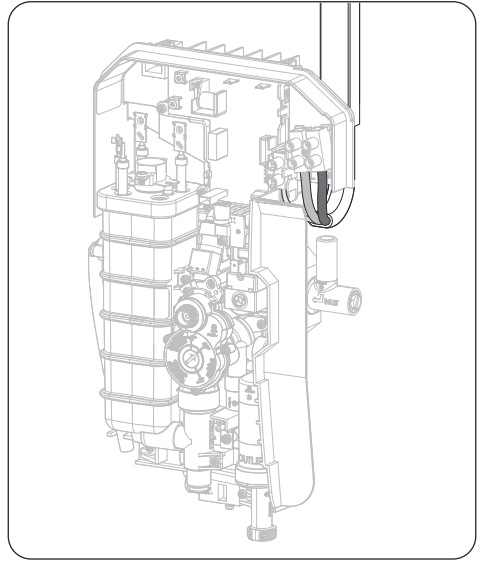

B. Top Right Cable Entry

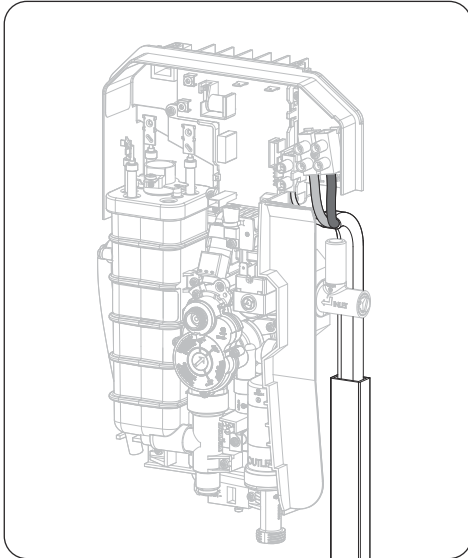

C. Bottom Right Cable Entry

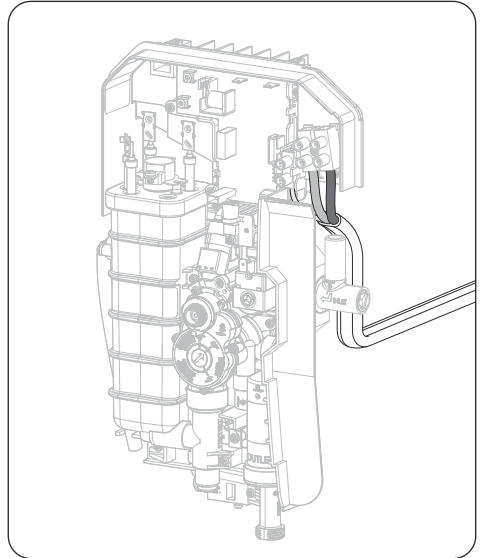

D. Rear Cable Entry

Electrical Connections

Switch off the electricity supply at the mains.

Fig.10 shows a schematic wiring diagram.

The cable entry points are shown in on page 18.

Route the cable into the shower unit and connect to the terminal block (**Fig.11**) as follows:

Earth cable to terminal marked 

Neutral cable to terminal marked **N**

Live cable to terminal marked **L**

Important: Fully tighten the terminal block screws and make sure that no cable insulation is trapped under the screws. Loose connections can result in cable overheating.

Note: The supply cable earth conductor must be sleeved. The outer sheath of the supply cable must be stripped back to the minimum.

The supply cable must be secured either by routing through conduit or in trunking or by embedding in the wall, in accordance with IEE regulations.

The use of connections within the unit, or other points in the shower circuit, to supply power to unspecified equipment, will invalidate the guarantee.

DO NOT switch on the electricity supply until the cover has been fitted.

Note: The elements on UK models are to 240V specification and will give a lower kW rating if the voltage supply is below 240V.

Warning!

After any servicing of mains water supply, always flush out the pipework to remove any debris.

In these circumstances the unit should only be re-started by following the commissioning procedure on page 23.

Fig.10

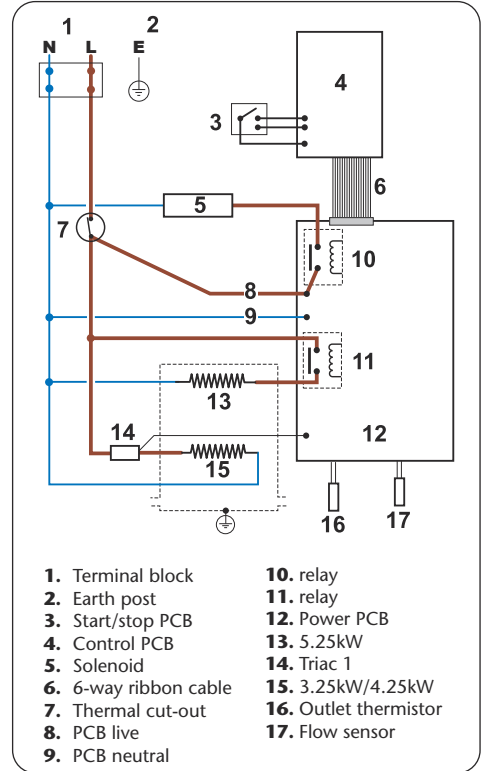
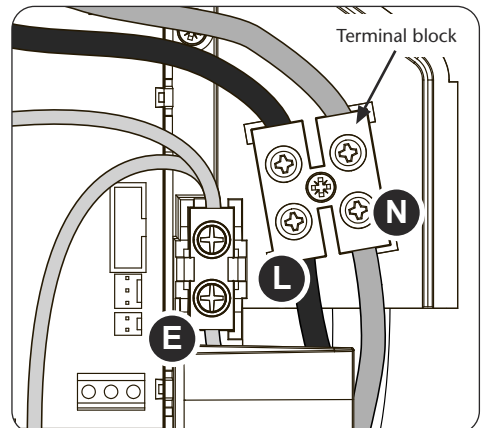

Fig.11



Shower Drain Pumps

Drain Pump Compatibility

The T150* has been designed to operate with the most popular drain pumps found on the market, please take time to fully understand the type of drain pump being fitted and the connection required to the electrical shower. During the installation process the correct DIP switch configuration must be selected (**see page 28**).

Analogue Drain Pump

When the shower is turned on, a signal is sent to the drain pump electronics telling the pump to start. When the shower is turned off, a signal is sent again to the drain pump electronics telling the pump to stop; generally after a preset time delay. This type of pump makes no allowance for the flow rate of the water from the shower, the 'gulp' or speed of the pump is fixed.

Connecting the Control Wire for Analogue

The pump manufacture provides a two core cable for connection to the shower unit.

The shower's internal Drain Pump Connector is shown in **Fig.12** and connect the electrical Control Wire as below:

- 1 - Not Used (connections numbered from left)
- 2 - Any
- 3 - Any

Note: Please reference the relevant Pump manufacturers installation instructions for Pump connection and relevant IEE regulations.

Digital Drain Pumps

When the shower is turned on, a digital signal is sent to the drain pump electronics telling the pump to start and the pump speed required. When the shower is turned off, the digital signal stops. This tells the drain pump electronics to stop; generally after a preset time delay. This type of pump varies the 'gulp' or pump speed based on the flow rate from the shower unit, the flow rate is measured by a flow sensor fitted within the shower and communicates this information to the drain pump through the digital signal.

Connecting the Control Wire for Digital

The pump manufacture provides a three core cable for connection to the shower unit.

The shower's internal Drain Pump Connector is shown in **Fig. 12** and connect the electrical Control Wire as below:

- 1 - +5V to +24V
- 2 - 0V dc
- 3 - Signal

Note: Please refer to the relevant pump manufacturers installation instructions for pump connection, relevant IEE regulations and full details of operation.

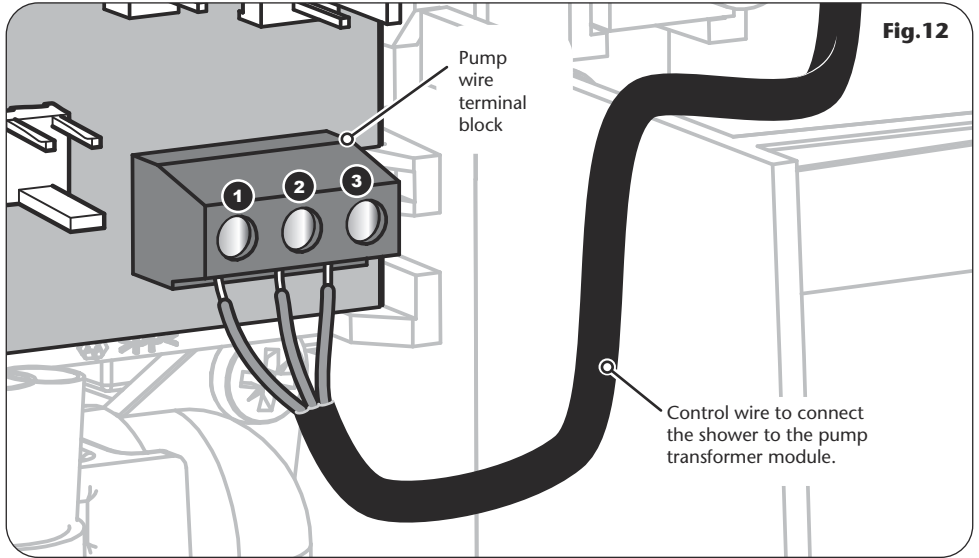

! WARNING !

The pump is a **non-gravity** installation. It is advised that where the property is left unattended for an extended period of time, that the water supply to the shower is **shut off**.

Shower Drain Pumps

Drain pumps are manufactured by the following companies but no endorsements are offered by Triton showers regarding third party products listed within this fitting book.

- | | |
|-----------------|---|
| AKW | http://www.akw-ltd.co.uk/ |
| Contour-showers | http://www.contour-showers.co.uk/ |
| Whale pumps | http://www.whalepumps.com/ |

For pump information please contact the appropriate manufacturer.

Pumps are not supplied with any products manufactured by Triton Showers.

If bottom entry has been chosen, fit the appropriate cut-out in the top of the cover (**Fig.13**).

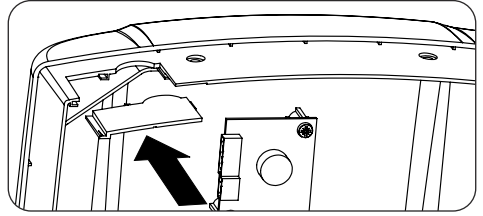
Fig.13

If top entry has been chosen, fit the appropriate cut-out in the bottom of the cover (**Fig.14**).

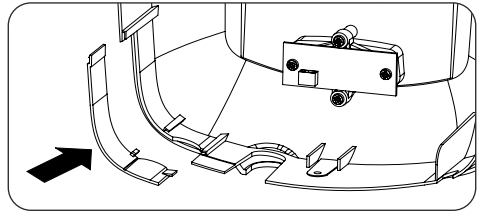
Fig.14

Commissioning

The first operation of the shower is intended to flush out any remaining unit debris and to make sure the heater unit contains water before the elements are switched on.

Temporarily fit the cover to the unit making sure that the connector is **NOT** plugged into the PCB fitted in the shower (**Fig.15**).

Temporarily fitting the cover

For ease of access to the Inlet fitting, the right hand side of the shower has a removable splash guard. This **MUST** be fitted before the cover, using two of the screws provided, to stop any water penetration of the shower during the commissioning procedure (**Fig.16**).

Once the splash guard is fitted offer the cover to the unit.

Guide the cover into position so that the temperature control spindle locates correctly (minor adjustment may be necessary to align the control and spindle). Secure the cover in position with the three retaining screws.

Fit the flexible hose to the shower outlet making sure the outlet of the hose is directed to waste. Check that the supplied sealing washer is in place.

DO NOT attach the showerhead at this stage.

Turn on the water supply to the shower at the isolating stop valve. Switch on the electricity supply to the shower at the isolating switch.

Wait until water starts to flow from the flexible hose.

It will take about thirty seconds for a smooth flow of water to be obtained while air and any debris is being flushed from the shower.

Once the flushing out has been completed, switch off the electricity to the shower at the isolating switch. The water will cease to flow.

Unscrew the top and bottom retaining screws again and lift off the cover.

Note: Removal of power to the PCB is the only way to exit the commissioning mode.

Fig.15

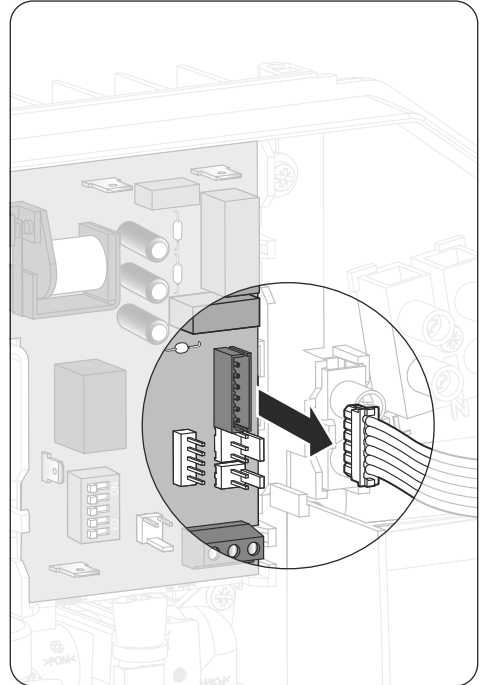
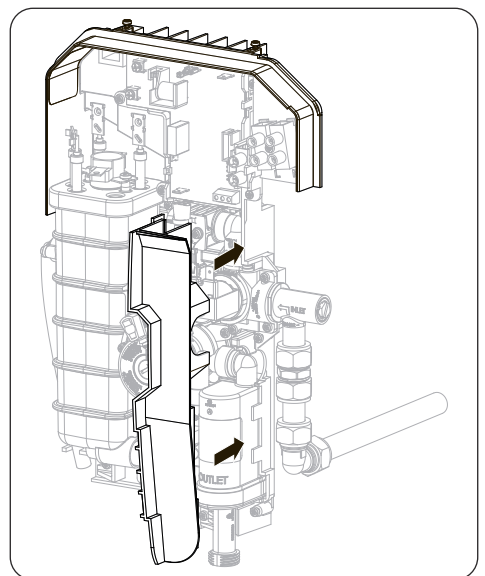

Fig.16



Fitting the Cover

Attached to the control PCB inside the cover, is a 6-way cable. The cable connector must be plugged into the socket located at the right of the power PCB situated inside the unit (**Fig.17**).

Note: The cable connector can be fitted to the socket only one way.

Important: Before finally fitting the cover, the following steps must be taken:

- a. Check all plumbing connections are watertight.
- b. Check terminal block screws are fully tightened.
- c. Make sure pipe and cable entering the unit do not prevent the cover locating correctly.
- d. Splash guard is secured.

Offer the cover to the unit.

Guide into position so that the temperature control lever locates correctly (minor adjustment may be necessary to align the lever and spindle). Should any difficulty arise, recheck the points above.

While applying slight pressure to the cover, secure in position with the three retaining screws.

Turn the electric supply back on at the isolating switch. The 'Power' indicator will light. No water will flow now until the **Start/Stop** button is pressed.

However, it is recommended that the water and electric supplies to the shower are turned off while the riser rail kit is being installed.

The flexible hose can be left attached to the shower outlet. Make sure the supplied sealing washer is fitted.

Fig.17

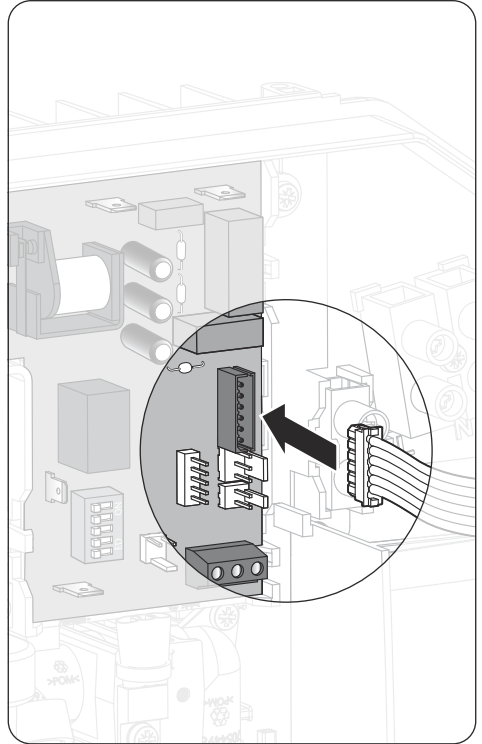

WARNING

COVER RETAINING SCREWS
ONLY the **SUPPLIED SCREWS** should be used. The use of none supplied screws **WILL** invalidate product specifications & warranty.

Adjusting the Maximum temperature selector 35°C to 47°C - Standard showering

Fig.18

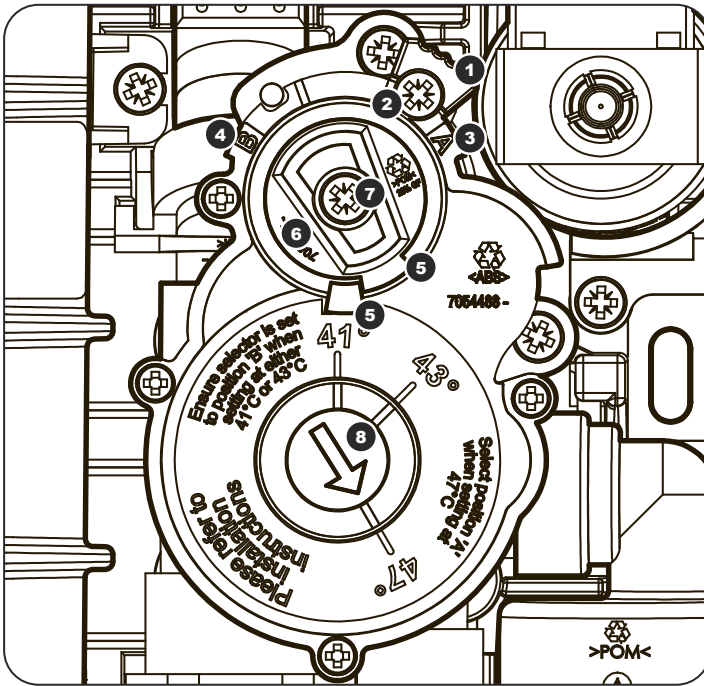

1. Position selector
2. Locking screw
3. Position A
4. Position B
5. Travel limit stops
6. Knob adaptor
7. Securing screw
8. Inner arrow

The temperature control valve has an adjustable maximum temperature selector mechanism that is supplied factory set at 47°C (**Fig.18**).

To select a lower maximum temperature setting, isolate the mains electricity supply to the shower. Remove the cover and disconnect the 6-way cable from the power PCB.

To adjust the maximum temperature please follow **Figs.19 - 23**. A brief description of the procedure is detailed below.

Remove the securing screw (**7**) from the knob adaptor (**6**) and remove knob adaptor (**6**). Rotate splined spindle so that the inner arrow (**8**) is aligned with either 43°C or 41°C marking line. Remove the locking screw (**2**) from the position selector (**1**), rotate position selector (**1**) to position 'B' (**4**) (minor adjustment of the splined spindle may be necessary to align internal gears). Insert the locking screw (**2**) to fix the position selector (**1**) in its new position. Refit the knob adaptor (**6**) ensuring that the travel limit stops (**5**) are engaged - **see Fig.23**. Reassemble securing screw (**7**).

Reconnect the ribbon cable, replace the cover assembly with the knob rotated to its maximum clockwise position for cover realignment, and restore mains electrical power supply to the unit.

IMPORTANT:

Please follow this procedure outlined on page 27 when altering the maximum stop to conform with the BEAB Care (41°) showering setting.

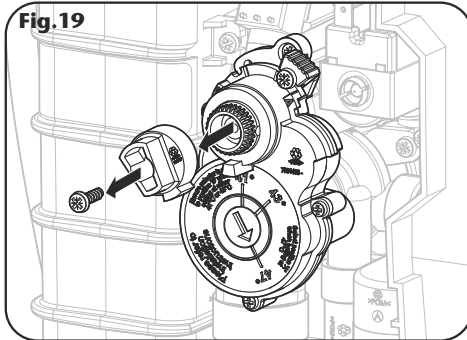

Remove the securing screw holding the adaptor in place.

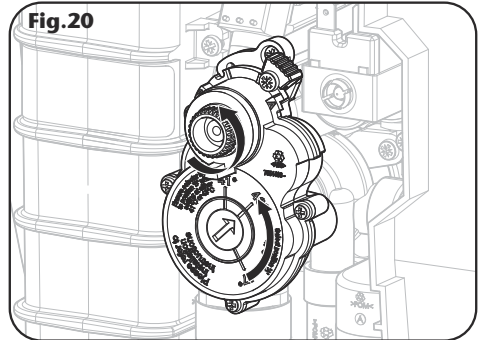

Rotate the inner arrow using the spined screwdriver until the arrow aligns with the desired temperature.

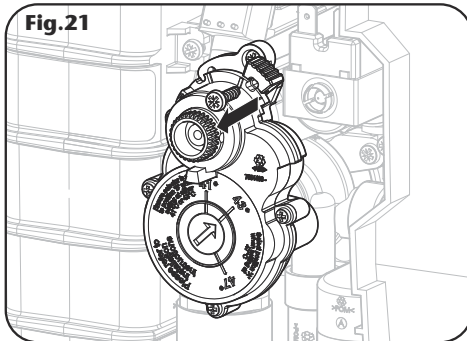

Remove the locking screw and slide the position selector to position B.

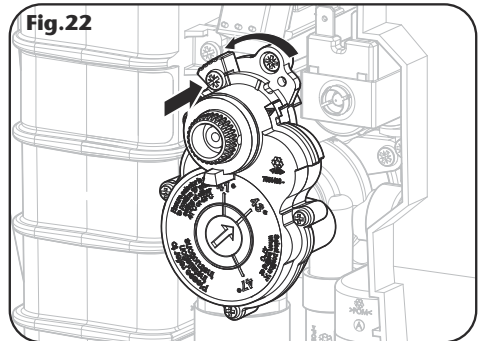

Replace the locking screw, fixing the position selector in position B.

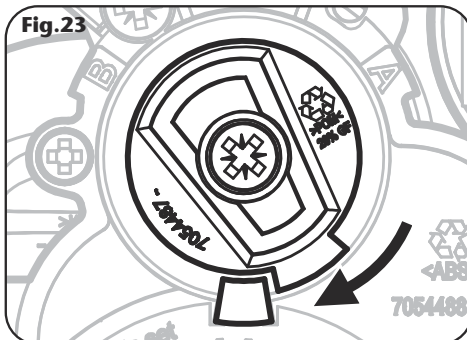

Replace the knob adapter so that it is orientated as shown in **Fig.23**

BEAB Care

Fig.24

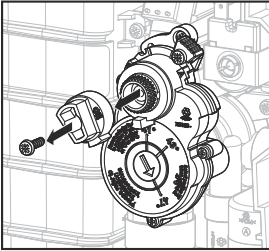

IMPORTANT INFORMATION:

*BEAB care mark specification states a **MAXIMUM** of 41°C outlet temperature.

If the shower is adjusted above the maximum 41°C the product falls outside the BEAB care mark specification.

Important: The 41°C marker on the thermostatic valve assembly is merely a guide. Further adjustment may be required to tune the maximum temperature of the unit to 41°C.

Fig.25

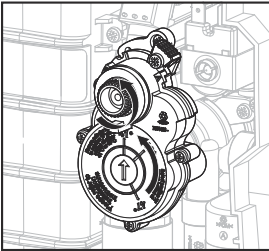

Setting the temperature stop to *41°C, BEAB Care use

Isolate the mains electricity supply to the shower.

Remove the cover and disconnect the ribbon cable from the power PCB.

Remove the securing screw holding the knob adaptor in place (Fig.24).

Rotate the splined spindle so that the inner arrow aligns with 41° (Fig.25).

The position selector should be set to position 'B' for BEAB care mode. Remove the locking screw and slide the position selector to position 'B' (Fig.26).

Reconnect the power PCB cable and replace the cover assembly.

Restore mains electrical power to the shower.

Start the shower by pressing the Start/Stop button.

The shower should run for a minimum of 30 seconds to allow the water temperature from the handset to stabilise.

Follow the instructions given on **page 36**.

Switch off the shower and isolate the unit from the mains electricity supply.

Fig.26

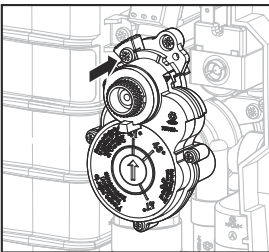
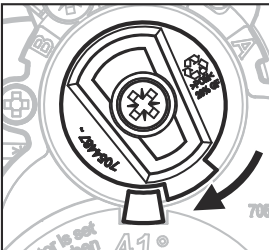

Fig.27



If the outlet temperature measured 41°C simply replace the knob adaptor making sure the travel limit stop is in its most clockwise position (Fig.27).

If further adjustment is required to achieve 41°C from the shower, rotate the splined spindle clockwise to increase the temperature or anti-clockwise to decrease the temperature.

Reconnect the power PCB cable and replace the cover assembly. Then remeasure the outlet temperature.

Replace the knob adaptor as shown in Fig.27.

Reconnect the ribbon cable, replace the cover assembly and restore mains electrical power to the unit.

Dip Switch Settings

A five way DIP switch block is mounted on the control PCB that allows the user to configure the shower to perform different functions (**Fig.28**).

Fig.28

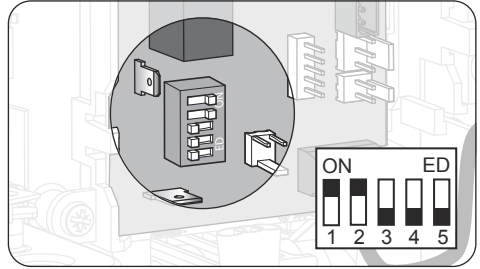

Dip Switch No.	Operation Enabled	Switch Position
DIP switch 1 On	Audible Feedback On (Factory Setting)	
DIP switch 1 Off	Audible Feedback Off	
DIP switch 2 Off DIP switch 3 Off	Timed Shutdown - 5 Mins	
DIP switch 2 Off DIP switch 3 On	Timed Shutdown - 10 Mins	
DIP switch 2 On DIP switch 3 Off	Timed Shutdown - 20 Mins (Factory Setting)	
DIP switch 2 On DIP switch 3 On	Timed Shutdown - 30 Mins	
DIP switch 4 On	Analogue Pump Setting	
DIP Switch 4 Off	Digital Pump Setting (Factory Setting)	
DIP Switch 4 Off DIP Switch 5 On	Digital Pump Setting 2200 Pulses - Per litre	
DIP Switch 4 Off DIP Switch 5 Off	Digital Pump Setting 1000 Pulses - Per litre (Factory Setting)	

Operating functions (Fig.29)

Power on indicator (green)

When the electricity supply to the shower is switched on at the isolating switch, the power on indicator will light up.

Low flow indicator (red)

If a low flow condition occurs the unit will turn off the water flow immediately and illuminate the low flow indicator. A rapid audible beep will also sound for 5 seconds (if the audible function is selected). It will be necessary to wait until water in the unit has reduced to a comfortable temperature, at which point the LED will extinguish. Pressing the start/stop button will then restart the unit.

Shutdown indicator (yellow)

This will illuminate if a 'Timed Shutdown' has been programmed into the unit, or the start/stop button has been pressed to stop the shower. When the indicator illuminates it indicates there is 1 minute before the timed shutdown setting. The indicator will then flash for 10 seconds prior to the shower switching off, an audible beep will also commence if it has been set to do so (see **commissioning section, for information on how to program the unit**).

Phased shutdown

In use, every time the **Start/Stop** button is pressed, power is switched off to the elements. Water will continue to flow for a few seconds, flushing out any remaining hot water. This makes sure the next immediate user will not receive a slug of hot water if standing under the showerhead when starting the shower.

Important: DO NOT switch off the shower using the isolating switch before the phased shutdown process has completed. This may damage the unit.

Temperature Protection

During normal operation if the flow of water through the unit is restricted power to the elements will be reduced to maintain the shower temperature. When the flow of water through the unit returns to normal, power to the elements will be automatically restored to the setting at the time of interruption.

Fig.29

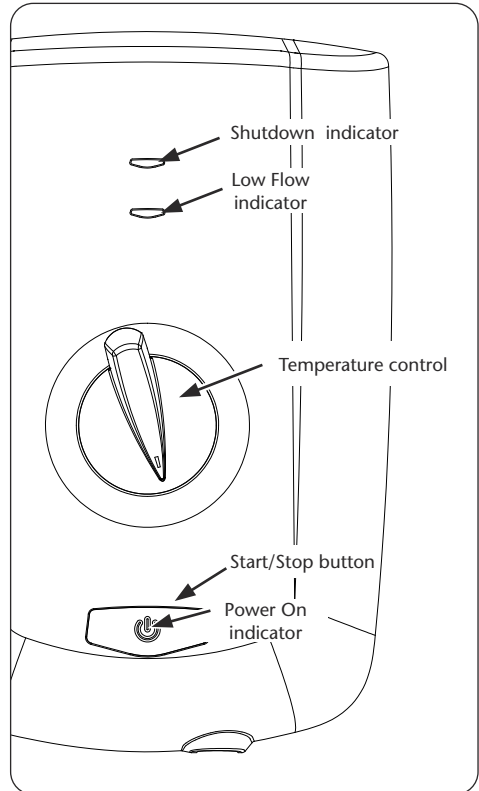

Safety cut-out

The unit is fitted with an over-temperature safety device. In the event of abnormal operation which could cause unsafe temperatures within the unit, the device will disconnect the heating elements and remove power from the electronics making the shower unit inoperable.

It will require a visit from a qualified engineer to identify the nature of the fault and replace the safety device.

IMPORTANT

The shower unit **MUST BE** switched off at the isolating switch when not in use. This is a safety procedure recommended for all electrical appliances.

Instructions for installers and service engineers only

Cleaning the Filter

It is recommended that the filter is periodically cleaned in order to maintain the performance of the shower. It is essential that this operation is carried out by a competent person.

Switch off the electricity and water supply at the mains.

The inlet filter is situated inside the water inlet fitting (**Fig.30**).

To gain access to the filter remove the cover. Unscrew the inlet filter cap on the water inlet fitting.

Inspect the O ring for damage when the filter is removed. Do not over tighten the filter cap on reassembly.

When cleaning the filter, **DO NOT** use a sharp object as it will cause damage. It is preferable to use an old toothbrush or similar.

Fig.30

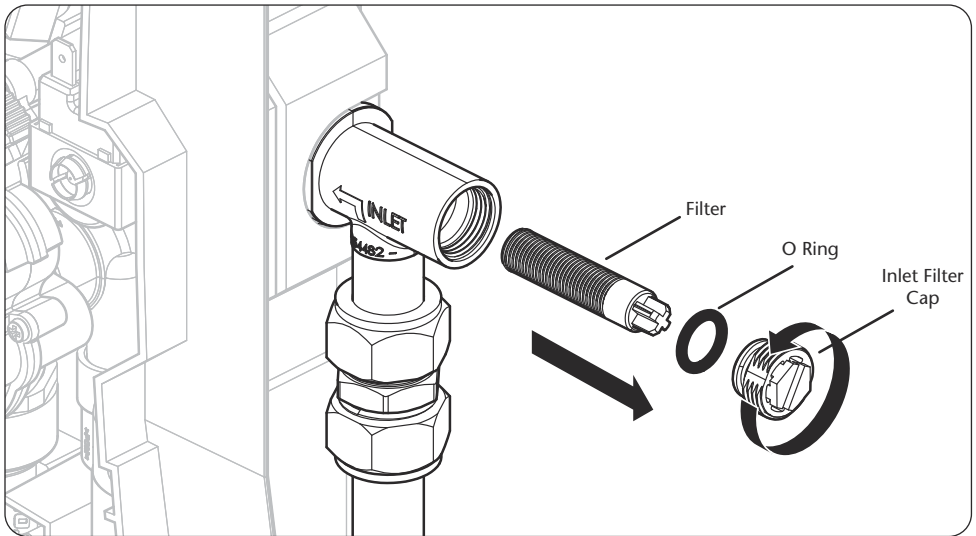

FAULT FINDING/TROUBLESHOOTING

Important: Switch off the electricity at the mains supply and remove the circuit fuse before attempting any fault finding inside the unit.

Problem/Symptom	Cause	Action/Cure
1 Shower inoperable, no water flow.	1.1 Interrupted power supply.	1.1.1 Blown fuse or circuit breaker. Check supply Renew or reset fuse or circuit breaker. If it fails again, consult a qualified electrician.
	1.2 Unit malfunction.	1.2.1 Power cut? Check other appliances and if necessary, contact local Electricity Supply Co.
		1.2.2 Have unit checked. Contact Customer Experience.
	1.3 Thermal cut-out operated.	1.3.1 The thermal cut-out safety device has operated. Have the unit checked by a suitably qualified service engineer or contact Customer Experience.
	1.4 PCB - NTC has operated.	1.4.1 The PCB has an NTC safety device which has operated. Have the unit checked by a suitably qualified service engineer or contact Customer Experience (lights and audio still in operation).
2 Water too hot.	2.1 Temperature control set incorrectly.	2.1.1 Alter the temperature control.
	2.2 Unit malfunction.	2.2.1 Have the unit checked by a suitably qualified service engineer or contact Customer Experience.
3 Water too cool or cold.	3.1 Temperature control set incorrectly.	3.1.1 Alter the temperature control.
	3.2 Maximum temperature selector set incorrectly.	3.2.1 Alter the maximum temperature selector.
	3.3 Unit malfunction.	3.3.1 Have the unit checked by a suitably qualified service engineer or contact Customer Experience.
4 Water will not stop flowing from unit unless switched off at isolating switch.	4.1 Control cable is not connected to PCB.	4.1.1 Remove cover and connect cable.

FAULT FINDING/TROUBLESHOOTING

Problem/Symptom	Cause	Action/Cure
5 Pressure relief device has operated (water ejected from PRD tube).	5.1 Blocked showerhead.	5.1.1 Clean sprayplate and then fit a new PRD.
	5.2 Twisted/blocked flexible shower hose.	5.2.1 Check for free passage through hose. Replace hose if necessary and then fit new PRD.
	5.3 Showerhead not removed while commissioning.	5.3.1 Fit new PRD. Commission unit with showerhead removed.
6 Low flow LED permanently on when start/stop bar pressed. Shower will not start.	6.1 Low flow condition	6.1.1 Insufficient water flow available. 1. Check showerhead is not blocked 2. Check shower hose is not restricted. 3. Check filter is not blocked. 4. Check water supply to shower is adequate
7 Low flow LED comes on when shower is running. Shower switches off.	7.1 Low flow condition has caused temperature sensor in the shower to operate.	7.1.1 Shower will not start until water in the unit has cooled and LED goes off. If problem persists. 1. Check showerhead is not blocked 2. Check shower hose is not restricted. 3. Check filter is not blocked. 4. Check water supply to shower is adequate
8 Low flow LED flashes continuously when start/stop bar pressed. Shower will not start.	8.1 Flow sensor has failed	8.1.1 Replace flow sensor assembly
9 Low flow and shutdown LED's alternately flashing when power turned on to unit. Shower will not start.	9.1 Start/Stop PCB failed	9.1.1 Replace cover assembly
10 Low flow and shutdown LED'S flashing simultaneously when start/stop bar pressed. Shower will not start.	10.1 Outlet thermistor failed	10.1.1 Replace thermistor

FAULT FINDING/TROUBLESHOOTING

Problem/Symptom	Cause	Action/Cure
11 Low flow and shutdown LED'S permanently on when power is turned on. Shower will not start.	11.1 Power pcb faulty	11.1.1 Replace power pcb
12 Low flow, shutdown & Start Stop LED'S all flashing simultaneously an audible alarm (If in use) will also be present.	12.1 NTC safety device operated. Note: After 3 failures on NTC, unit will continue to show same fault.	12.1.1 The PCB has an NTC safety device which has operated. Have the unit checked by a suitably qualified service engineer or contact Customer Experience.

Note: Identify cause of operation before fitting new PRD unit. When fitting a new PRD, follow the commissioning procedure.

It is advised all electrical maintenance/repairs to the shower should be carried out by a suitably qualified person.

In the unlikely event of unit failure other than detailed in the fault finding page, please contact Customer Experience for advice.

Important:

These tests should only be performed by a qualified engineer.

Commissioning and In-Service Tests**D.1 Commissioning****D.1.1 Purpose**

Since the installed supply conditions are likely to be different from those applied in production it is appropriate, at commissioning, to carry out some simple checks and tests on each instantaneous water heater to provide a performance reference point for future in-service tests.

D.1.2 Procedure

D.1.3 With the appliance turned off check that:

- a) The water supply temperature is within the range 5 to 20°C;
- b) The terminal voltage at the appliance is within the range $230 \pm 10\%$.

D.1.4 Turn on the appliance and if the maximum outlet water temperature is adjustable, adjust this in accordance with the manufacturer's instructions to the maximum permitted BEAB care temperature. Then carry out the following sequence:

- a) Record the supply voltage at the terminals of the appliance;
- b) Record the outlet water temperature and the flow rate resulting from the setting;
- c) Reduce the water supply flow rate at the inlet of the appliance by at least 50% or to the lowest value at which the appliance continues to deliver an output of heated water, whichever is the greater pressure;
- d) Record the outlet water temperature and the reduced flow rate.

The outlet water temperature should not exceed 43°C for a shower;

- e) Record details of the equipment, thermometers etc. used for the measurements.

D.2 In-service tests**D.2.1 Principle**

The purpose of in-service tests is regularly to monitor and record the performance of the instantaneous water heater. Deterioration in performance can indicate the need for service work on the appliance and/or the water supplies.

D.2.2 Procedure

D.2.3 Using the measuring equipment recorded in D.1.4 or equipment to the same specification and with the appliance turned off check that:

- a. The water supply temperature is within the range 5 to 20°C;
- b. The terminal voltage at the appliance is within the range $230 \pm 10\%$

D.2.4 If the set maximum outlet water temperature has changed significantly from the previous test results (e.g. $> 1^\circ\text{C}$), record the change and before re-setting the maximum outlet water temperature check:

- a) That any outlet fittings are not blocked and are free of scale;
- b) That any in-line or integral strainers are clean;
- c) Any in-line or integral check valves or other backflow prevention devices are in good working order;
- d) Any isolating valves are fully open.

D.2.5 With an acceptable outlet water temperature, complete the following procedure:

- a) Record the supply voltage at the terminals of the appliance;
- b) Record the outlet water temperature and the flow rate resulting from the setting;
- c) Reduce the water supply flow rate at the inlet of the appliance by at least 50% or to the lowest value at which the appliance continues to deliver an output of heated water, whichever is the greater pressure;
- d) Record the outlet water temperature and the reduced flow rate;

NOTE: The outlet water temperature should not exceed 43°C for a shower and washbasin.

- e) Record details of the equipment, thermometers etc. used for the measurements.

D.2.6 If at step D.2.5 b) the outlet water temperature is greater than the values given in the note to D.2.5 d) then service work is indicated.

D.3 Frequency of in-service tests

D.3.1 General

In-service tests should be carried out with a frequency which identifies a need for service work before an unsafe water temperature can result. In the absence of any other instruction or guidance on the means of determining the appropriate frequency of in-service testing, the following procedure may be used:

D.3.1.1 6 to 8 weeks after commissioning, conduct the tests given in D.2.2 to D.2.6.

D.3.1.2 12 to 15 weeks after commissioning, conduct the tests given in D.2.2 to D.2.6.

D.3.1.3 Depending on the results of D.3.1.1 and D.3.1.2 several possibilities exist:

- a) If no significant changes (e.g. $\leq 1^{\circ}\text{C}$) in outlet water temperatures are recorded between commissioning and D.3.1.1, or between commissioning and D.3.1.2 the next in-service test can be deferred to 24 to 28 weeks after commissioning;
- b) If small changes (e.g. 1 to 2°C) in outlet water temperatures are recorded in only one of these periods, necessitating adjustment of the outlet water temperature, then the next in-service test can be deferred to 24 to 28 weeks after commissioning;
- c) If small changes (e.g. 1 to 2°C) in outlet water temperatures are recorded in both of these periods, necessitating adjustment of the outlet water temperature, then the next in-service test should be carried out at 18 to 21 weeks after commissioning;
- d) If significant changes (e.g. $> 2^{\circ}\text{C}$) in outlet water temperatures are recorded in either of these periods, necessitating service work, then the next in-service test should be carried out at 18 to 21 weeks after commissioning or earlier.

D.3.1.4 The general principle to be observed after the first 2 or 3 in-service tests is that the intervals of future tests should be set to those which previous tests have shown can be achieved with no more than a small change in outlet water temperature.

To purchase a genuine Triton spare part for your product, please visit **www.tritonshowers.co.uk/spares** for product codes and prices. Alternatively please call our Customer Experience team on **024 7637 2222** to order direct. Please have your model name available.

WEEE Directive – Policy Statement

As a producer and a supplier of electric showers, Triton Showers is committed to the protection of the environment via our own environmental policy and compliance with the **WEEE directive**.

Triton Showers is fully registered with the Environment Agency under the following scheme:

Repic: Producers take-back scheme (PTS), registration number WEE/EJ3466QV

All our electric products are labelled accordingly with the crossed out wheeled bin symbol. This indicates, for disposal purposes at end of life, that these products must be taken to recognised collection points, such as local authority sites/local recycling centres; this will be free of any charges. **Do not return to Triton Showers.**







UK SERVICE POLICY

In the event of a product fault or complaint occurring, the following procedure should be followed:

DO NOT REMOVE THE PRODUCT

1. Telephone Customer Experience on **024 7637 2222** having available your details including post code, the model number and power rating of the product, together with the date of purchase and, where applicable, details of the particular fault.
2. If required, the Customer Experience Advisor will arrange for a qualified engineer to call.
3. All products attended to by a Triton service engineer must be installed in full accordance with the Triton installation guide applicable to the product. Every product pack contains an installation guide, however, they can also be downloaded free at www.tritonshowers.co.uk.
4. Our engineer will require local parking and if a permit is required, this must be available to the engineer on arrival at the call.
5. If loft access is required for isolation or to complete a repair, the loft must have a fixed access ladder and be boarded, with appropriate lighting from the access point to and around the repair area.
6. It is essential that you or an appointed representative, who must be over 18 years of age, is present for the duration of the service engineer's visit. If the product is in guarantee you must produce proof of purchase.
7. Where a call under the terms of guarantee has been booked and the failure is not product related (i.e. scaling and furring, incorrect water pressure, pressure relief device operation or electrical/plumbing installation fault) a charge will be made. A charge will also be issued if nobody is at the property when the service engineer calls or adequate parking/permit is not available.
8. If the product is no longer covered by the guarantee an up-front fixed fee will be charged before the site visit.
9. Your receipt must be retained as proof of purchase. Should proof of purchase not be available on an 'in-guarantee' call, or should the service engineer find that the product is no longer under guarantee, the engineer will charge the same fixed price and will request payment prior to departing. If payment is not made on the day an administration charge will be added to the fixed charge.
10. If a debt is outstanding from a previous visit, or from any other Triton purchase, Triton reserves the right to withhold service until the debt has been settled.
11. Triton takes the health, safety and wellbeing of its employees very seriously and expects customers to treat all staff members with respect. Should any employee feel threatened or receive abuse, either verbally or physically, Triton reserves the right to withhold service.

Replacement Parts Policy

In line with AMDEA guidelines, Triton retains functional spares for as long as there is a market for them and in most cases, well beyond. Due to the vast array of product types, the life cycle of products can vary and therefore so can the length of time parts can be supplied. Spare parts can be ordered via our online spare parts store or by telephoning Triton Customer Experience team on **024 7637 2222**. Payment should be made by credit / debit card (excluding American Express or Diners Card). Payment can also be made by pre-payment of a pro-forma invoice, by cheque or postal order.

Telephone orders are based on information given during the call. Before contacting Triton, please verify your requirements using the Triton website or your professional installer. Triton cannot accept liability for incorrect part identification.

Triton Showers
Triton Road
Nuneaton
Warwickshire, CV11 4NR

Triton is a division of Norcross Group (Holdings) Limited

Triton reserve the right to change product specification without prior notice. E&OE. © TRITON SHOWERS 2020

TRITON UK STANDARD GUARANTEE

This guarantee applies only to products installed within the United Kingdom and does not apply to products used commercially. This guarantee does not affect your statutory rights.

With the exception of accessories, Triton guarantee the product against all manufacturing defects for a period of **2 years** (for domestic use only) from the date of purchase, provided that it has been installed by a competent person in full accordance with the fitting instructions.

All accessories such as shower heads, hoses and riser rails carry a **1 year** parts only guarantee against manufacturing defects.

Any part found to be defective during this guarantee period we undertake to repair or replace at our option without charge, so long as it has been properly maintained and operated in accordance with the operating instructions and has not been subject to misuse or damage. This product must not be taken apart, modified or repaired except by a person authorised by Triton.

What is not covered:

1. Breakdown due to:
 - a) use other than domestic use by the property occupants;
 - b) wilful act or neglect;
 - c) any malfunction resulting from the incorrect use or quality of electricity, gas or water or incorrect setting of controls;
 - d) failure to install in accordance with this installation guide.
2. Claims for missing parts once the product has been installed.
3. Repair costs for damage caused by foreign objects or substances.
4. Total loss of the product due to non-availability of parts.
5. Compensation for loss of use of the product or consequential loss of any kind.
6. Call out charges due to an abortive visit or where no fault has been found with the appliance.
7. The cost of repair or replacement of isolating switches, electrical cable, fuses and/or circuit breakers or any other accessories installed at the same time. Replacement of the Pressure Relief Device that only activates when the shower outlet is blocked is also excluded.
8. The cost of routine maintenance, adjustments, overhaul modifications or loss or damage arising therefrom, including the cost of repairing damage, breakdown, malfunction caused by corrosion, furring, frost or exposure to freezing conditions.
9. Callout charges where the water supply cannot be isolated, this includes consequential losses arising from unserviceable supply valves, or inaccessible product or valves located in a loft space without suitable access.

For the latest Terms & Conditions please see:

www.tritonshowers.co.uk/terms

PLEASE NOTE PRODUCT REGISTRATION IS ONLY AVAILABLE TO UNITS PURCHASED & INSTALLED IN THE UK

Customer Experience: **024 7637 2222**

Trade Installer Hotline: **024 7637 8344**

www.tritonshowers.co.uk

E-mail: serviceenquiries@tritonshowers.co.uk

E-mail: technical@tritonshowers.co.uk