

TRITON

T301 INSTAFLOW Handwash

**REGISTER ONLINE
ENTER A PRIZE DRAW**

**WIN
£100**

RETAIL VOUCHERS

VISIT OUR WEBSITE TODAY

TRITONSHOWERS.CO.UK/REGISTER

*PRODUCT REGISTRATION IS ONLY AVAILABLE
TO UNITS PURCHASED & INSTALLED IN THE UK*

FOR YOUR SERVICE REFERENCE

NOTE DOWN THE PRODUCT CODE BELOW
(FROM THE FRONT OR TOP OF THE BOX)

ALTERNATIVELY REGISTER BY TEL: 024 7637 8321



IMPORTANT SAFETY ADVICE

The swivel arm supplied with this product is a safety critical part of your shower. Failure to use genuine Triton parts may cause injury and invalidate your guarantee.

INSTALLATION AND OPERATING INSTRUCTIONS

Please read this book thoroughly and familiarise yourself with all instructions before commencing installation and keep it for future reference.

The handwash installation **MUST** be carried out by a suitably qualified person, **in the sequence of this instruction book.**



PLEASE READ THIS IMPORTANT SAFETY INFORMATION

Products manufactured by Triton are safe and without risk provided they are installed, used and maintained in good working order in accordance with our instructions and recommendations.

- ⚠ WARNING:** The appliance must not be positioned where it will be subjected to freezing conditions. If suspected of being frozen, do not use.
- ⚠ DO NOT** operate the appliance if the spray arm becomes damaged.
- ⚠ DO NOT** restrict flow out of the spray arm by placing arm in direct contact with your body.
- ⚠ DO NOT** operate the appliance if water ceases to flow during use or if water has entered inside the unit because of an incorrectly fitted cover.
- ⚠ WARNING:** If restarting the appliance immediately after stopping, be aware that a slug of hot water will be expelled for the first few seconds.
- ⚠** The spray head and rings must be descaled regularly.
- ⚠** Fit only the spray head recommended by the manufacturer and never fit any additional device to restrict the water outlet flow.
- ⚠** The outlet must not be connected to any tap or fitting other than those specified.
- ⚠** This appliance is intended to be permanently connected to the water mains and not connected by a hose set.
- ⚠** The water inlet of this appliance shall not be connected to inlet water obtained from any other water heating system.
- ⚠ WARNING:** This appliance is not to be used to provide a potable water supply.
- ⚠** Always disconnect the appliance from the supply before assembling, disassembling or cleaning.

Mains water pressure only.
Minimum inlet pressure 100kPa (1 bar)
Maximum inlet pressure 1000kPa (10 bar)

This book contains all the necessary fitting and operating instructions for your handwash.

Care taken during the installation will provide a long, trouble-free life from your handwash.

⚠ WARNING ⚠

This appliance can be used by children aged from 3 years and above and persons with reduced physical, sensory or mental capabilities or lack of experience and knowledge if they have been given supervision or instruction concerning use of the appliance in a safe way and understand the hazards involved. Children may not play with the appliance. Cleaning and user maintenance shall not be made by children.



IMPORTANT - PLEASE READ THESE GENERAL GUIDANCE NOTES BEFORE PROCEEDING



1 GENERAL

- 1.1 Isolate the electrical and water supplies before removing the cover.
- 1.2 Read all of these instructions and retain them for later use.
- 1.3 **DO NOT** take risks with plumbing or electrical equipment.
- 1.4 Isolate electrical and water supplies before proceeding with the installation.
- 1.5 The unit must be mounted onto the finished wall surface (on top of the tiles). **DO NOT** tile up to or seal around **ANY PART** of the unit using silicone sealer after fixing to the wall. Special care must be taken **NOT TO BLOCK OR SEAL ANY PRD VENTS ON THE UNIT.**
- 1.6 Contact Triton Customer Experience (*see back page*), if any of the following occur:
 - a) *If it is intended to operate the handwash at pressures above the maximum or below the minimum stated.*
 - b) *If the unit shows a distinct change in performance.*
 - c) *If the handwash is frozen.*
- 1.7 If it is intended to operate the handwash in areas of hard water (above 200 ppm temporary hardness), a scale inhibitor may have to be fitted. For advice on the Scale Inhibitor, contact Triton Customer Experience.
- 1.8 The sprayhead must be cleaned regularly with descaler to remove scale and debris, otherwise restrictions to the flow on the outlet of the unit will result in higher temperatures and could also cause the (PRD) Pressure Relief Device in the unit to operate.
- 1.9 This product is not suitable for mounting into steam rooms or steam cubicles.

2 PLUMBING

- 2.1 The plumbing installation must comply with Water Regulations, Building Regulations or any particular regulations as specified by Local Water Company or Water Undertakers and should be in accordance with BS EN 806.
- 2.2 The supply pipe must be flushed to clear debris before connecting to the handwash unit.

- 2.3 **DO NOT** solder pipes or fittings within 300mm of the handwash unit, as heat can transfer along the pipework and damage components.
- 2.4 **DO NOT** fit any form of outlet flow control as the outlet acts as a vent for the heater can.
- 2.5 **DO NOT** use excessive force when making connections to the swivel arm or sprayhead, finger tight is sufficient.
- 2.6 All plumbing connections must be completed before making the electrical connections.
- 2.7 This appliance **MUST NOT** be connected to the inlet supply by a hose-set.

3 ELECTRICAL

- 3.1 The installation must comply with BS 7671 'Requirements for Electrical Installations' (IEE wiring regulations), building regulations or any particular regulations as specified by the local Electrical Supply Company.
- 3.2 This appliance **MUST** be earthed.
- 3.3 In accordance with 'The Plugs and Sockets etc. (Safety) Regulations 1994', this appliance is intended to be permanently connected to the fixed wiring of the electrical mains system.
- 3.4 Make sure all electrical connections are tight to prevent overheating.
- 3.5 A 30mA residual current device (RCD) **MUST** be installed in all UK electric circuits. This may be part of the consumer unit or a separate unit.
- 3.6 Switch off immediately at isolating switch if water ceases to flow during use.
- 3.7 Other electrical equipment i.e. extractor fans, pumps etc. must not be connected to the circuits within the unit.
- 3.8 If the product is to be left unattended for a significant amount of time without use, Triton recommends the product is isolated from the electricity supply.

- 3.9 As with all electrical appliances it is recommended to have the handwash and installation checked at least every two years by a competent electrician to ensure there is no deterioration due to age and usage.

To check the product suitability for commercial and multiple installations, please contact Triton's specification advisory service before installation. Please see back of book for contact information.

INTRODUCTION

This book contains all the necessary fitting and operation instructions for your Triton T301 Instaflo handwash. Please read carefully.

The installation must be carried out by a suitably qualified person and in the sequence of this instruction book.

SPECIFICATIONS

Electrical

Nominal power rating at 240V	Nominal power rating at 230V
3kW – 13A	2.8kW – 13A

Water

Inlet connection – **1/2" BSP thread**
Outlet connection – **1/2" BSP thread**

Entry Points

Water – **Right: bottom**
Cable – **Right: top, bottom or middle back**

Materials

Backplate, cover, control knobs – **ABS**
Elements – Minerally insulated corrosion resistant metal sheathing.

Dimensions without Spout

T301
Height – 183mm
Width – 228mm
Depth – 92mm

Standards and Approvals

Splashproof rating **IPX4**
Complies with the requirements of current British and European safety standards for household and similar electrical appliances.
Complies with requirements of the British Electrotechnical Approvals Board (BEAB).
Meets with Compliance with European Community Directives (CE).

ADVICE TO USERS

The following information will help you understand how the handwash product operates.

The electric heating elements operate at a constant rate. It is the flow rate of the water passing through the heater can which determines the water temperature at any given setting. The slower the flow, the hotter the water becomes and the faster the flow, the cooler the water.

During winter the mains water supply will be cooler than in summer, therefore, the water temperature of the handwash unit will vary between seasons on any one setting of the temperature control. To alter the temperature, simply adjust the control knob to the desired temperature.

The stabiliser valve minimises variations in water temperature during mains water pressure changes. If changes in water temperature are experienced during normal use, it will most likely be caused by the water pressure falling near to or below the minimum level. The drop in pressure may be due to water being drawn off at other points whilst the handwash is in use. If the pressure drops appreciably below the minimum, the heating elements will automatically cut out.

DO NOT place items such as soap or shampoo bottles on top of the unit. Liquid could seep through the joint between the cover and back plate and possibly damage the sealing rubber.

If water becomes too hot and you cannot obtain cooler water, first check that the sprayhead is not blocked. Secondly check the inlet water supply filter.

INTRODUCTION

IMPORTANT SAFETY INFORMATION & GENERAL GUIDANCE NOTES *(please read)*

GENERAL ADVICE TO USERS

Specification and advice to users.....4

Key to main components and entry points..... 6

Electrical requirements..... 7

Water requirements 8

Siting of the unit 8

Fitting the unit to the wall..... 9

Plumbing connections..... 10

Electrical connections 11

Fitting the swivel arm and cover..... 12

Commissioning..... 13

Operating the handwash 14

Operating functions..... 14

Cleaning..... 15

Flow rates and temperatures 16

Fault finding 17 - 18

Spare parts 19

Guarantee, service policy, etc.....rear cover

PRODUCT FICHE	
Model	3.0kW
Load Profile	XXS
Energy Efficiency Class	A
Energy Efficiency (%)	38
Annual Electricity Consumption (kwh)	496
Sound Power Level (db)	15

MAIN COMPONENTS

NOTE: Not all wiring is shown for reasons of clarity

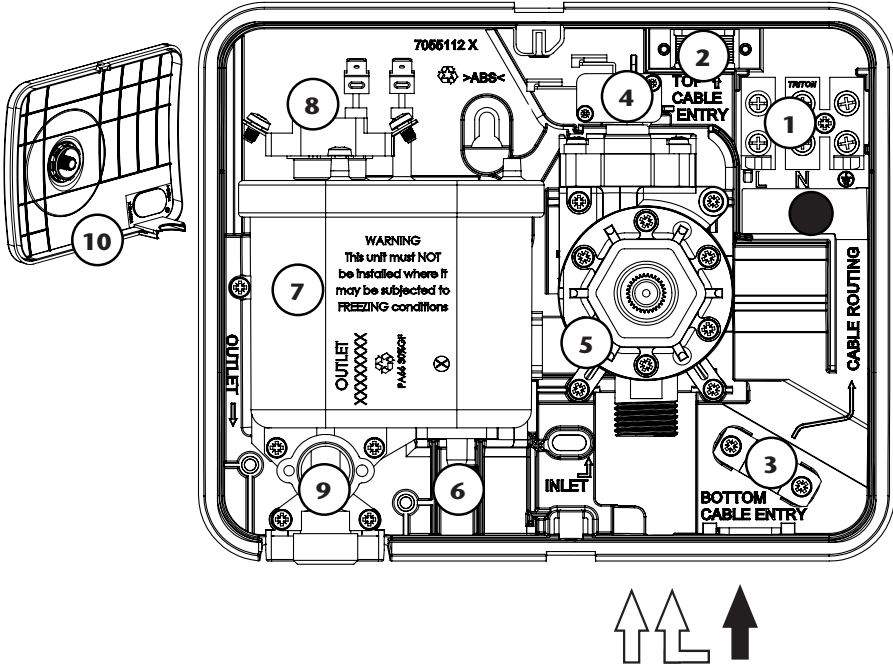

Inside Unit

1. Terminal block
2. Cable clamp top
3. Cable clamp bottom
4. Microswitch
5. Stabiliser valve
6. Pressure Relief Device (PRD)
7. Can assembly 3kW
8. Thermal Cut-Out (TCO)
9. Outlet pipe
10. Cover

Package Contents

- Handwash unit
- Cover screw pack
- 200mm swivel arm
- Instruction booklet including guarantee

Entry Points Key:



Water Entry Point



Cable Entry Points

Fig. 1

ELECTRICAL REQUIREMENTS

WARNING!
THIS APPLIANCE MUST BE EARTHED

The installation, supply cable and circuit protection must conform with BS7671 (IEE wiring regulations) and be sufficient for the amperage required.

The following notes are for guidance only:

- 1** The unit must only be connected to a 230 - 240V ac supply.
- 1.1** The electrical rating of the unit is shown on the rating label (**fig.2**) within the unit.
- 2** Before making any sort of electrical connection within the installation, make sure that no terminal is live. If in any doubt, switch off the whole installation at the consumer unit.
- 3** The 3kW rated handwash can be connected to a ring main via a 13A fused spur.
- 3.1** The electrical supply must be adequate for the loading of the unit and existing circuits.
- 4** A 30mA residual current device (RCD) must be installed in all UK electric circuits. This may be part of the consumer unit or a separate unit.



Fig.2

Table A

CIRCUIT PROTECTION		
unit rating	MCB	cartridge fuse
3.0kW	-	13A

Table B

Twin and earth PVC insulated cable CURRENT CARRYING CAPACITY		
installed in an insulated wall	in conduit or trunking	clipped direct or buried in a non insulated wall
1.5mm ²	1.5mm ²	1.5mm ²
14A	16A	19A

Note: Cable selection is dependent on derating factors

Minimum 1.5mm flexible cord in conjunction with the cable clamp should be used when using top or bottom cable entries.

Twin and Earth flat PVC cable should NOT be used for clipped direct installation method.

Surface mounted cable installations should be suitably supported by equally spaced clips on the wall.

WATER REQUIREMENTS

The installation must be in accordance with Water Regulations and Bylaws.

To guarantee activation of the heating elements, the unit must be connected to a mains water supply with a minimum running pressure of 100kPa (1.0 bar) at a minimum flow rate of four litres/minute and a maximum static pressure of 1000kPa (10 bar).

NOTE: If the stated flow rates are not available, it may not be possible to achieve optimum performance from the unit throughout the year. The water supply can be taken from a cold water storage cistern provided there is a minimum head of ten metres above the unit. It must be an independent supply to the handwash unit only.

If it is intended to operate the unit at pressures above the maximum or below the minimum stated, contact Triton Customer Experience for advice.

SITING OF THE UNIT

IMPORTANT: This product **MUST ONLY** be connected to cold water inlet mains pipework.

Fig.3 shows a typical system layout. **DO NOT** use jointing compounds on any pipe fittings for the installation.

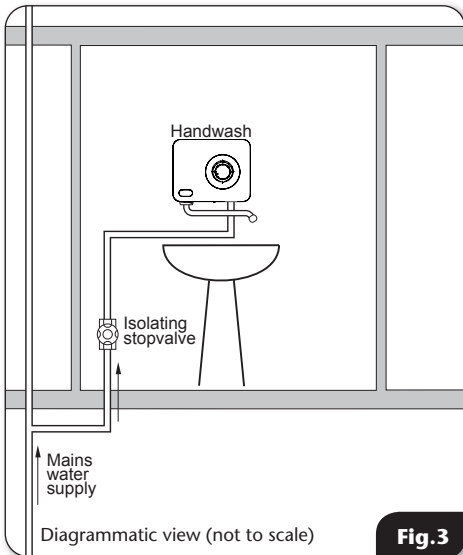

Pressure Relief Safety Device

A pressure relief device (PRD) is designed into the handwash unit which complies with European Standards. The PRD provides a level of appliance protection should an excessive build up of pressure occur within the unit.

DO NOT operate the handwash with a damaged or blocked sprayhead; this can cause the PRD to operate.

When commissioning, the sprayhead must be removed from the swivel arm and the temperature control must be at the minimum flow position. Failure to follow this procedure may also cause the PRD to operate.

Make sure the handwash is positioned over a sink or basin, because if the PRD operates, water will eject from the bottom of the unit. Should this happen, turn off the electricity and water supplies to the unit at the isolating switch and stop valve.

Contact Triton Customer Experience for advice on replacing the PRD.

FITTING THE UNIT TO THE WALL

⚠ WARNING

CHECK THERE ARE NO HIDDEN CABLES OR PIPES BEFORE DRILLING HOLES FOR WALL PLUGS. USE GREAT CARE WHEN USING POWER TOOLS NEAR WATER. THE USE OF A RESIDUAL CURRENT DEVICE (RCD) IS RECOMMENDED WHEN USING POWER TOOLS.

IMPORTANT: The unit must be mounted on a flat surface, on top of tiles which cover the full width and length of the backplate. It is important that the wall surface is flat otherwise difficulty may be encountered when fitting the cover and subsequent operation of the unit may be impaired. DO NOT tile up to or seal around any part of the unit using silicone sealer after fixing to the wall. Special care must be taken not to block or seal any PRD vents on the unit.

The control knob is an integral part of the cover — DO NOT attempt to remove it.

Entry position for the mains water is at the bottom. Entry for electrical supplies are at the top, bottom or back of the unit.

If top or bottom entry position is chosen, the cable entry not being used should have the pipe trim inserted (**fig.4**).

Procedure

Position the unit on the wall and using the backplate as a template, mark the two fixing holes (**fig.5**).

Drill and plug the wall. An appropriate drill bit should be used. If the wall is brick, plasterboard or a soft building block, appropriate wall plugs and screws should be fitted.

Screw the top fixing screw into position leaving the base of the screw head protruding 6mm out from the wall. Hook the backplate over the top screw and fit the bottom fixing screw into position.

DO NOT fully tighten the screws at this stage, as the fixing holes are elongated to allow for out of square adjustment after the plumbing connections have been completed.

IMPORTANT: Using a suitable sealant, always seal around the incoming pipework to prevent water entering the wall.

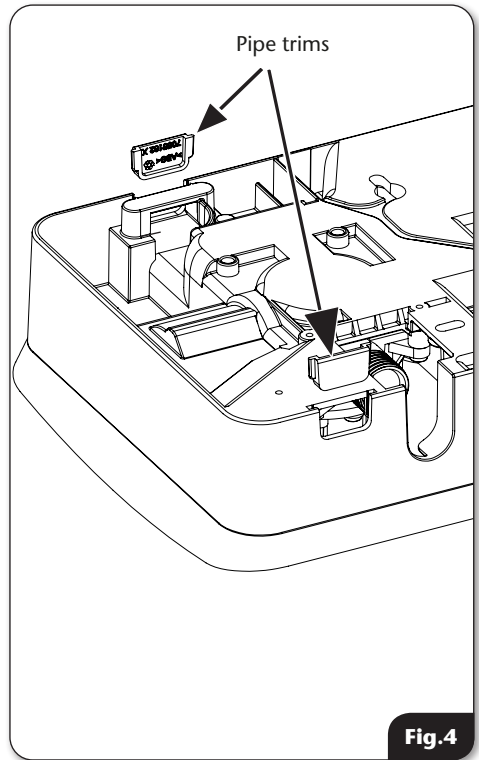

Fig.4

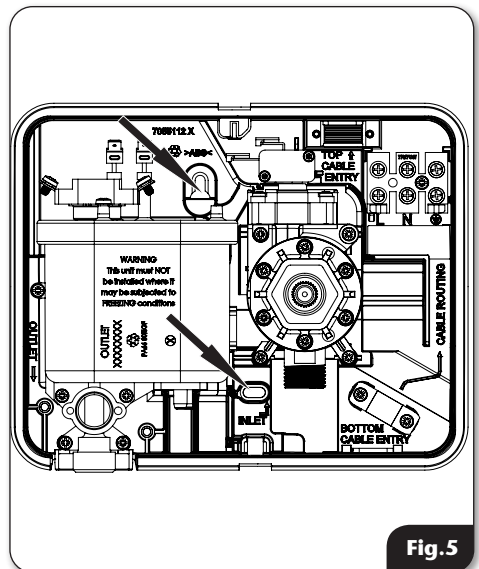

Fig.5

ELECTRICAL CONNECTIONS

SWITCH OFF THE ELECTRICITY SUPPLY AT THE MAINS.

Fig.8 shows a schematic wiring diagram

The cable can be surface clipped, hidden or via 20mm conduit. For this handwash unit the minimum cable size will be 1.5mm².

The supply cable earth conductor must be sleeved. The outer sheath of the supply cable must be stripped back to the minimum. For top cable entry, remove sufficient outer sheath to assist routing beneath and looping back into the terminal block - DO NOT remove too much.

Conduit entry can only be from rear. Route the cable into the unit and connect to the terminal block (**fig.9**) as follows:

Earth cable to terminal marked 

Neutral cable to terminal marked N

Live cable to terminal marked L

IMPORTANT: When connecting the cable, fully tighten the terminal block screws and make sure that no cable insulation is trapped under the screws - loose connections can result in cable overheating. Make sure the cable is fully secured by the cable clamp provided (**fig.10**). If top entry is used, move the cable clamp from its position at the bottom entry position to the top entry position.

The use of connections within the unit, or other points in the circuit, to supply power to other equipment i.e. extractor fans, pumps etc. will invalidate the guarantee.

DO NOT switch on the electricity supply until the cover has been fitted and the unit commissioned.

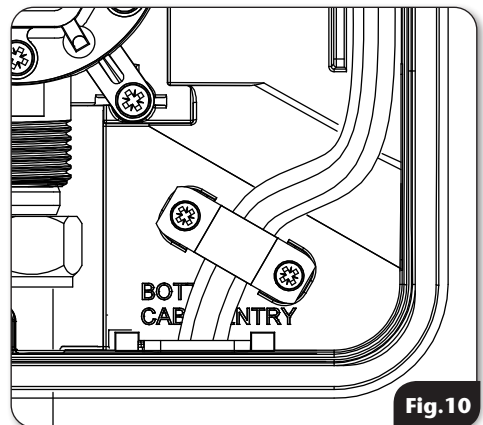
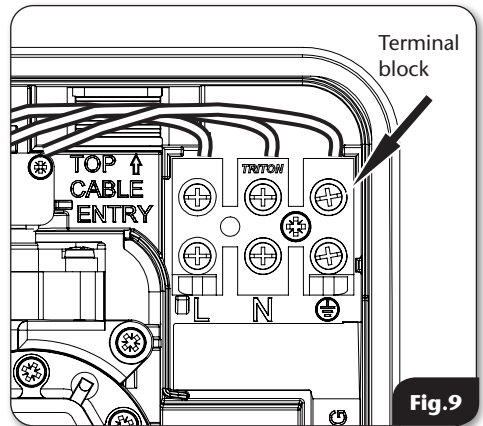
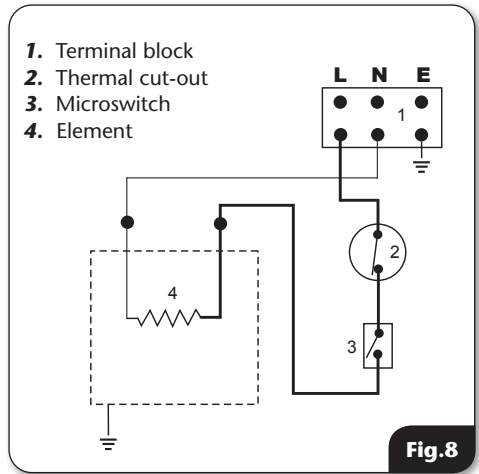

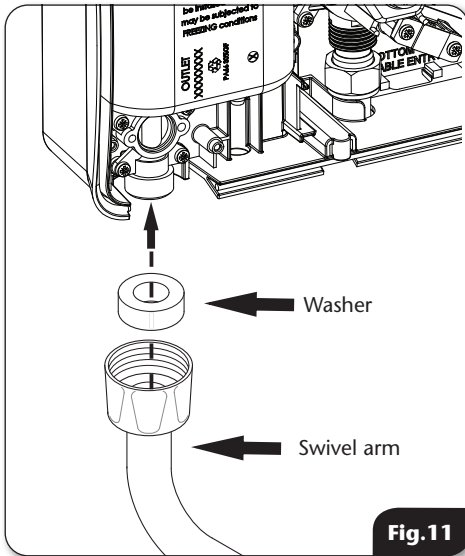



Fig.11

FITTING SWIVEL ARM

Insert the washer into the swivel arm and screw onto the outlet pipe connection (**fig.11**).

FITTING THE COVER

To ensure that the temperature control is correctly positioned on the stabiliser valve, temporarily place the cover in position so that the splines engage. Rotate the temperature control fully clockwise.

Remove the cover and position the temperature control so that it points at the  position (**fig.12**). Replace the cover squarely to the backplate and guide into position so that the control locates correctly into the splined spindle. Should any difficulty arise, recheck the points above.

Secure the cover in position with the two retaining screws at the top and bottom of the unit.

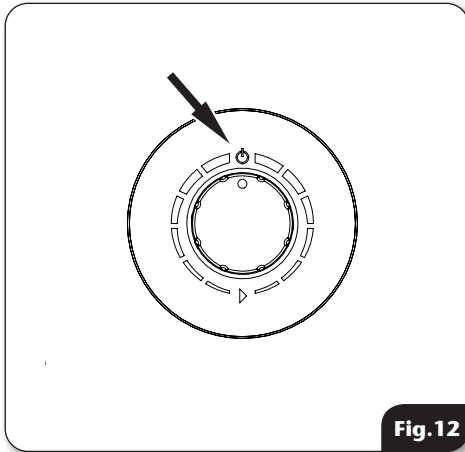

Fig.12

IMPORTANT

PLEASE ENSURE COVER SCREWS ARE FULLY TIGHTENED DOWN TO PREVENT WATER ENTERING THE HANDWASH UNIT.

ONLY THE SUPPLIED SCREWS SHOULD BE USED. THE USE OF NON SUPPLIED SCREWS WILL INVALIDATE PRODUCT SPECIFICATIONS & GUARANTEE.

COMMISSIONING



WARNING



BEFORE NORMAL OPERATION OF THE HANDWASH, IT IS ESSENTIAL THE FOLLOWING COMMISSIONING PROCEDURE IS COMPLETED CORRECTLY.

The first operation of the unit is intended to flush out any unit debris and to ensure the heater unit contains water before the elements are switched on.

Make sure the electricity is switched OFF at the isolating switch and that the cold mains water supply is turned ON at the units isolating valve. Check that the swivel arm is directed to waste.

Make sure that the swivel arm is screwed to the outlet pipe, **but remove the sprayhead (fig.13)**.

Rotate the temperature control fully anti-clockwise to the minimum flow position (**fig.14**). **NOTE:** Leaving the control at any position other than minimum may cause the PRD to operate.

Wait until water starts to flow from the swivel arm then rotate the control fully clockwise to the maximum flow position (**fig.15**).

It will take about thirty seconds for a smooth flow of water to be obtained while air and any debris is being dispersed from the unit. When a smooth flow of water is obtained, rotate the control from minimum to maximum and back again several times to release any trapped air.

Once flushing out has been completed, stop the water flow by rotating the control to the  position.

Screw the sprayhead assembly back on to the swivel arm - hand tight should be sufficient.

Switch on the electricity supply to the handwash at the isolating switch.

The unit is now ready for normal operation.

NOTE: The unit does not need the power supply to be turned on for cold mains water to be able to flow through it.

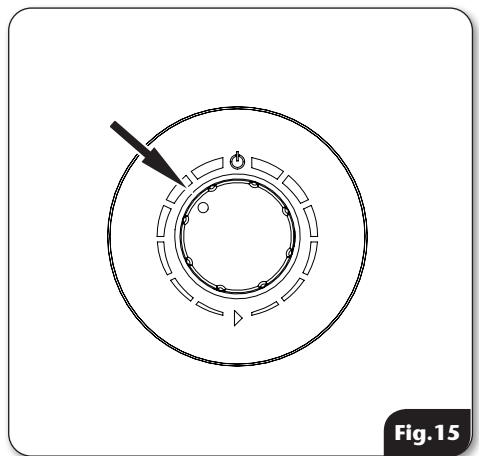
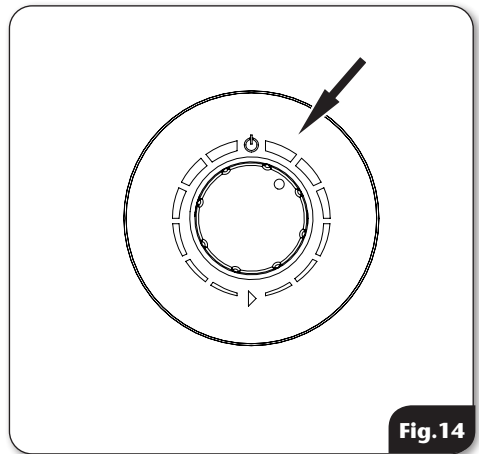
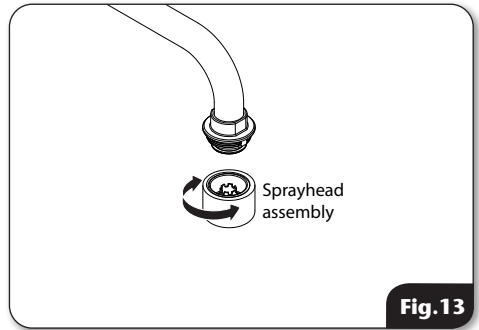

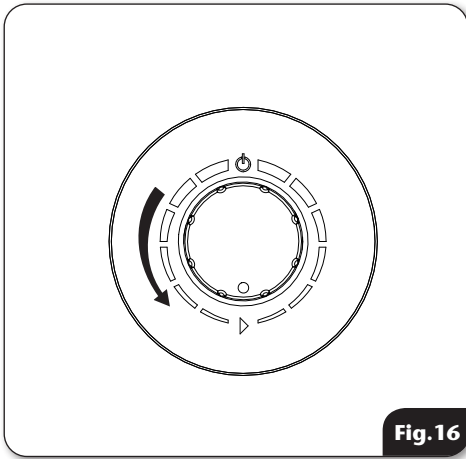

Fig. 16

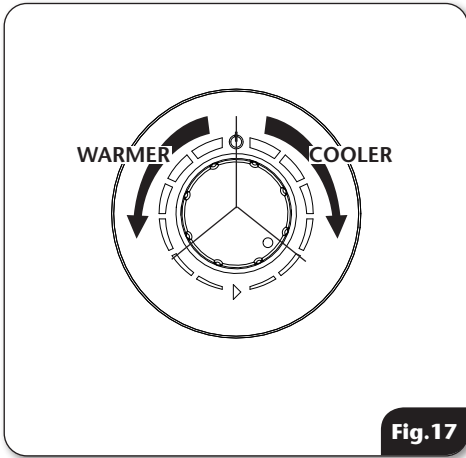

Fig. 17

OPERATING THE HANDWASH

To start the handwash unit

Turn the temperature control anti-clockwise and the water will begin to flow.

The flow of water is controlled by the combined start/stop temperature control.

To obtain warm water turn the control slowly anti-clockwise to the mid position (**fig.16**).

If the water is too hot, turn the control slowly clockwise. If the water is too cool, turn the control slowly anti-clockwise (**fig17**).

NOTE: There will always be a short time delay between selecting a flow rate and reaching the stable temperature for that flow rate.

To stop the handwash unit

Turn the temperature control fully clockwise to the  position and water will cease to flow.

WARNING

IF RESTARTING IMMEDIATELY AFTER STOPPING, BE AWARE THAT A SLUG OF HOT WATER WILL BE EXPELLED FOR THE FIRST FEW SECONDS.

NOTE: It is normal practice to leave the water supply permanently connected to the handwash unit when not in use.

OPERATING FUNCTIONS

Low Water Pressure Cut-out

If the water pressure falls below the minimum required for correct operation of the unit, power will be switched off to the heating elements preventing any maintained temperature rises; water will continue to flow. Power will automatically be restored when adequate water pressure returns.

Safety Cut-out

The unit is fitted with a non-resettable thermal cut-out safety device. In the event of abnormal operation which could cause unsafe temperatures within the unit, the device will disconnect the heating elements. It will require a visit from a qualified engineer to determine the nature of the fault and replace the safety device once the unit has been repaired.

IMPORTANT: After any servicing of the mains water supply, always make sure the unit is run with no power supplied to it - see Commissioning section for details.

CLEANING THE SPRAYHEAD

IMPORTANT: Before cleaning, turn off the unit at the isolation switch to avoid the handwash being accidentally switched on. Cleaning can be carried out with the swivel arm removed or still attached to the handwash unit.

DO NOT use powerful abrasive or solvent cleaning fluids when cleaning the sprayhead assembly as they may damage the plastic fittings.

The sprayhead is a critical part of the unit. In order to maintain maximum performance, the sprayhead assembly should be cleaned at regular intervals to prevent build up of deposits from the water supply. Blocked spray holes can reduce the water flow to such an extent that it will cause the thermal cut-out or PRD to operate.

When the unit is first installed the sprayhead assembly may need cleaning due to debris that may be left in the pipework after installation. Following this, the frequency of cleaning will depend upon the type of water available. Hard water areas may require cleaning once a week whereas soft water areas may only require cleaning every six months.

Procedure

Unscrew the sprayhead assembly from the swivel arm and separate the sprayplate from the sprayhead (**fig.18**). Clean with a suitable brush, ensuring all traces of scale are removed from the spray holes. Rinse in clean water and refit the assembly.

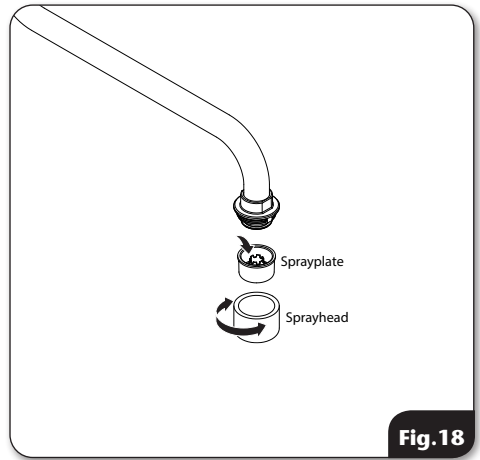

Fig.18

FLOW RATES & WATER TEMPERATURES

The temperature of the water coming flowing from the unit depends on:

- The temperature of the mains water supply
- The water flow rate through the unit
- The power level of the unit
- The electric supply voltage

The temperature of the water supply can vary from 5°C in the winter to about 20°C in summer, with an average of about 12°C. The table below shows a scenario of the water temperature you can expect at different flow rates in litres/minute.

Power Rating	Flow L/Min	Outlet Temp °C	
3.0kW @ 240V	1 l/min	48°C	Winter
	2 l/min	27°C	
	3 l/min	19°C	
	1 l/min	*55°C	Average
	2 l/min	34°C	
	3 l/min	26°C	
	1 l/min	*63°C	Summer
	2 l/min	42°C	
	3 l/min	35°C	

* Thermal cut-out activation will occur.

FAULT FINDING

IMPORTANT: Switch OFF the electricity at the mains supply and remove the circuit fuse before removing the cover from the handwash while attempting any fault finding inside the unit.

It is advised all electrical maintenance/repairs to the handwash unit should be carried out by a suitably qualified person.

Problem	Cause	Action
1 Unit inoperable, no water flow.	1.1 No mains water supply to unit.	1.1.1 Check if isolating valves are fully open. Check if a blockage in inlet filter or in pipework.
	1.2 Unit malfunction.	1.2.1 Have unit checked. Contact Triton Customer Experience.
2 Water too hot.	2.1 Not enough water flowing through the unit.	2.1.1 Increase the flow rate. 2.1.2 Blocked sprayhead - clean or replace sprayhead.
	2.2 Blockage in supply.	2.2.1 Check if stop valves are fully open. Check if blockage in inlet filter.
	2.3 Increase in ambient water temperature.	2.3.1 Increase the flow rate.
3 Water temperature cycling hot/cold at intervals.	3.1 Heater cycling on thermal cut- out.	3.1.1 See 'Water too hot' causes 2.1, 2.2 and 2.3 and their appropriate actions. If it continues, contact Triton Customer Experience.
4 Water too cool or cold.	4.1 Too much flow.	4.1.1 Reduce the flow rate.
	4.2 Water pressure below minimum stated on rating label	4.2.1 Is water supply mains or tank fed?
		4.2.2 If tank fed, replumb to mains water supply or see 4.2.4.
		4.2.3 If mains fed, ensure that mains stop valve is fully open and that there are no other restrictions in the supply while the unit is in use, or see 4.2.4.
		4.2.4 Fit a pump to give minimum pressure. Contact Triton Customer Experience for advice.
4.3 Reduction in ambient water temperature.	4.3.1 Reduce the flow rate.	
4.4 Electrical malfunction.	4.5 Interrupted power supply.	4.4.1 Have unit checked by suitably qualified electrician or contact Triton Customer Experience.
		4.5.1 Blown fuse or circuit breaker. Check supply. Renew or reset fuse or circuit breaker. If it fails again, consult a qualified electrician.
		4.5.2 Power cut. Check other appliances and if necessary, contact local Electricity Supply Company.

FAULT FINDING

Problem	Cause	Action
5 Unit varies from normal temperature to cold during use.	5.1 Water pressure has dropped below minimum required	5.1.1 Wait until the water pressure resumes to normal.
6 Pressure relief device has operated (water ejected from PRD tube).	6.1 Blocked sprayhead.	6.1.1 Clean or replace sprayhead and then fit new PRD. Note: Identify cause of operation before fitting new PRD unit. When fitting a new PRD, follow the commissioning procedure.

To purchase a genuine Triton spare part for your product, please visit **www.tritonshowers.co.uk/spares** for product codes and prices. Alternatively please call our Customer Experience team on **024 7637 2222** to order direct. Please have your model name available.

WEEE Directive – Policy Statement

As a producer and a supplier of electric showers, Triton Showers is committed to the protection of the environment via our own environmental policy and compliance with the **WEEE directive**.

Triton Showers is fully registered with the Environment Agency under the following scheme:

Repic: Producers take-back scheme (PTS), registration number WEE/EJ3466QV

Valpak: Distributor Takeback Scheme (DTS) registration number DTS-700160

All our electric products are labelled accordingly with the crossed out wheeled bin symbol. This indicates, for disposal purposes at end of life, that these products must be taken to recognised collection points, such as local authority sites/local recycling centres; this will be free of any charges. **Do not return to Triton Showers.**



UK SERVICE POLICY

In the event of a product fault or complaint occurring, the following procedure should be followed:

DO NOT REMOVE THE PRODUCT

1. Telephone Customer Experience on **024 7637 2222** having available your details including post code, the model number and power rating of the product, together with the date of purchase and, where applicable, details of the particular fault.
2. If required, the Customer Experience Advisor will arrange for a qualified engineer to call.
3. All products attended to by a Triton service engineer must be installed in full accordance with the Triton installation guide applicable to the product; this can be downloaded free at www.tritonshowers.co.uk/guides.
4. Our engineer will require local parking and if a permit is required, this must be available to the engineer on arrival at the call.
5. If loft access is required for isolation or to complete a repair, the loft must have a fixed access ladder and be boarded, with appropriate lighting from the access point to and around the repair area.
6. It is essential that you or an appointed representative (who must be over 18 years of age) is present for the duration of the service engineer's visit. If the product is in guarantee you must produce proof of purchase.
7. Where a call under the terms of guarantee has been booked and the failure is not product related (i.e. scaling and furring, incorrect water pressure, pressure relief device operation or electrical/plumbing installation fault) a charge will be made. A charge will also be issued if nobody is at the property when the service engineer calls or adequate parking/permit is not available.
8. If the product is no longer covered by the guarantee an up-front fixed fee will be charged before the site visit.
9. Your receipt must be retained as proof of purchase. Should proof of purchase not be available on an 'in-guarantee' call, or should the service engineer find that the product is no longer under guarantee, the engineer will charge the same fixed price and will request payment prior to departing. If payment is not made on the day an administration charge will be added to the fixed charge.
10. If a debt is outstanding from a previous visit, or from any other Triton purchase, Triton reserves the right to withhold service until the debt has been settled.
11. Triton takes the health, safety and wellbeing of its employees very seriously and expects customers to treat all staff members with respect. Should any employee feel threatened or receive abuse, either verbally or physically, Triton reserves the right to withhold service.

Replacement Parts Policy

In line with AMDEA guidelines, Triton retains functional spares for as long as there is a market for them and in most cases, well beyond. Due to the vast array of product types, the life cycle of products can vary and therefore so can the length of time parts can be supplied. Spare parts can be ordered via our online spare parts store or by telephoning our Triton Customer Experience team on **024 7637 2222**. Payment should be made by credit/debit card (excluding American Express or Diners Card). Payment can also be made by pre-payment of a pro-forma invoice, by cheque or postal order.

Telephone orders are based on information given during the call. Before contacting Triton, please verify your requirements using the Information contained in the user guide. Triton cannot accept liability for incorrect part identification.

Triton Showers
Triton Road
Nuneaton
Warwickshire, CV11 4NR

Triton is a division of Norcross Group (Holdings) Limited

Triton reserve the right to change product specification without prior notice. E&OE. © TRITON SHOWERS 2024

TRITON UK STANDARD GUARANTEE

This guarantee applies only to products installed within the United Kingdom and does not apply to products used commercially. This guarantee does not affect your statutory rights.

With the exception of accessories, Triton guarantee the product against all manufacturing defects for a period of **1 year** (for domestic or light commercial use only) from the date of purchase, provided that it has been installed by a competent person in full accordance with the fitting instructions.

All accessories such as shower heads, hoses and riser rails carry a **1 year** parts only guarantee against manufacturing defects.

Any part found to be defective during this guarantee period we undertake to repair or replace at our option without charge, so long as it has been properly maintained and operated in accordance with the operating instructions and has not been subject to misuse or damage. This product must not be taken apart, modified or repaired except by a person authorised by Triton.

What is not covered:

1. Breakdown due to:
 - a) wilful act or neglect;
 - b) any malfunction resulting from the incorrect use or quality of electricity, gas or water or incorrect setting of controls;
 - c) failure to install in accordance with this installation guide.
2. Claims for missing parts once the product has been installed.
3. Repair costs for damage caused by foreign objects or substances.
4. Total loss of the product due to non-availability of parts.
5. Compensation for loss of use of the product or consequential loss of any kind.
6. Call out charges due to an abortive visit or where no fault has been found with the appliance.
7. The cost of repair or replacement of isolating switches, electrical cable, fuses and/or circuit breakers or any other accessories installed at the same time. Replacement of the Pressure Relief Device that only activates when the shower outlet is blocked is also excluded.
8. The cost of routine maintenance, adjustments, overhaul modifications or loss or damage arising therefrom, including the cost of repairing damage, breakdown, malfunction caused by corrosion, furring, frost or exposure to freezing conditions.
9. Call out charges where the water supply cannot be isolated, this includes consequential losses arising from unserviceable supply valves, or inaccessible product or valves located in a loft space without suitable access.

For the latest Terms & Conditions please see:

www.tritonshowers.co.uk/terms

PLEASE NOTE PRODUCT REGISTRATION IS ONLY AVAILABLE TO UNITS PURCHASED & INSTALLED IN THE UK

Customer Experience: 024 7637 2222

Trade Installer Hotline: 024 7637 8344

www.tritonshowers.co.uk

E-mail: CXsupport@tritonshowers.co.uk

E-mail: technical@tritonshowers.co.uk