

# SERVICEKIT

Salamander **GENUINE** parts  
SKELECT10 ELECT



**ESP 100/120 PUMPS  
& IRISH VERSION**  
Salamander Pumps 

Making  
**water**  
perform



Instructions **VIDEOLINK:**



## Salamander Pumps Shower Systems Limited

Unit 2c Colima Avenue, Enterprise Park West,  
Sunderland, SR5 3XE

**Telephone:** 0191 516 2002

**Facsimile:** 0191 548 4445

**Email:** sales@salamanderpumps.co.uk

[www.salamanderpumps.co.uk](http://www.salamanderpumps.co.uk)



### PLEASE NOTE:

By using the parts included in this pack to repair your pump, you will be invalidating any warranty you have on the pump.

### Returns:

If you need to return this pack for any reason please ensure the original packaging and these instructions leaflets are returned also. If you have any questions or queries regarding this spares pack or any other pump related questions please contact us.

### UK:

Salamander Pumped Shower Systems Limited  
Unit 2c, Colima Avenue Enterprise Park West  
Sunderland SR5 3XE

Tel: 0191 516 2002

Email: tech@salamanderpumps.co.uk

### Eire:

MTA agencies Ireland Fearn House,  
Unit 4 Jamestown Business Park  
Jamestown Road Finglas,  
Dublin 11

Tel: +353 (0)1 864 3363

Email: service@mtagencies.ie

**WARNING! ENSURE PUMP IS ISOLATED FROM  
ELECTRICITY AND WATER SUPPLY. IF IN  
DOUBT CONSULT A COMPETENT  
TRADESMAN.**

**Pump should be serviced in horizontal  
position with couples disconnected and water  
and electricity supply isolated.**

**DO NOT RUN PUMP DRY. ALLOW WATER TO  
FILL PUMP TO LUBRICATE SEALS BEFORE  
STARTING. CHECK FOR LEAKS DURING TEST  
BEFORE BEING SATISFIED PUMP IS OK**

## INTRODUCTION

ESP 50/55 PUMPS and IRISH versions

### Tools required :

- PZ2 Screwdriver
- 7mm Deep Socket
- Long nose Pliers
- Snips
- PZ1 Screwdriver

### Parts in Service kit:

- Float- PFLOAT01(13) x 2
- NRV - CNRVPL01 (41) x 2
- HE Cold -EHALLE01 (17)
- HE Hot- EHALLE03 (17)
- Cable Tie Blue -FCABLE02 (35)
- Cable Tie Red- FCABLE03 (35)
- Interface (New)- EPCBES01 (5)
- Screw 6 x 1/2" - FScrew 11 x 2 (31)
- Screw SS Grub - FScrew 02 x 2 (42)

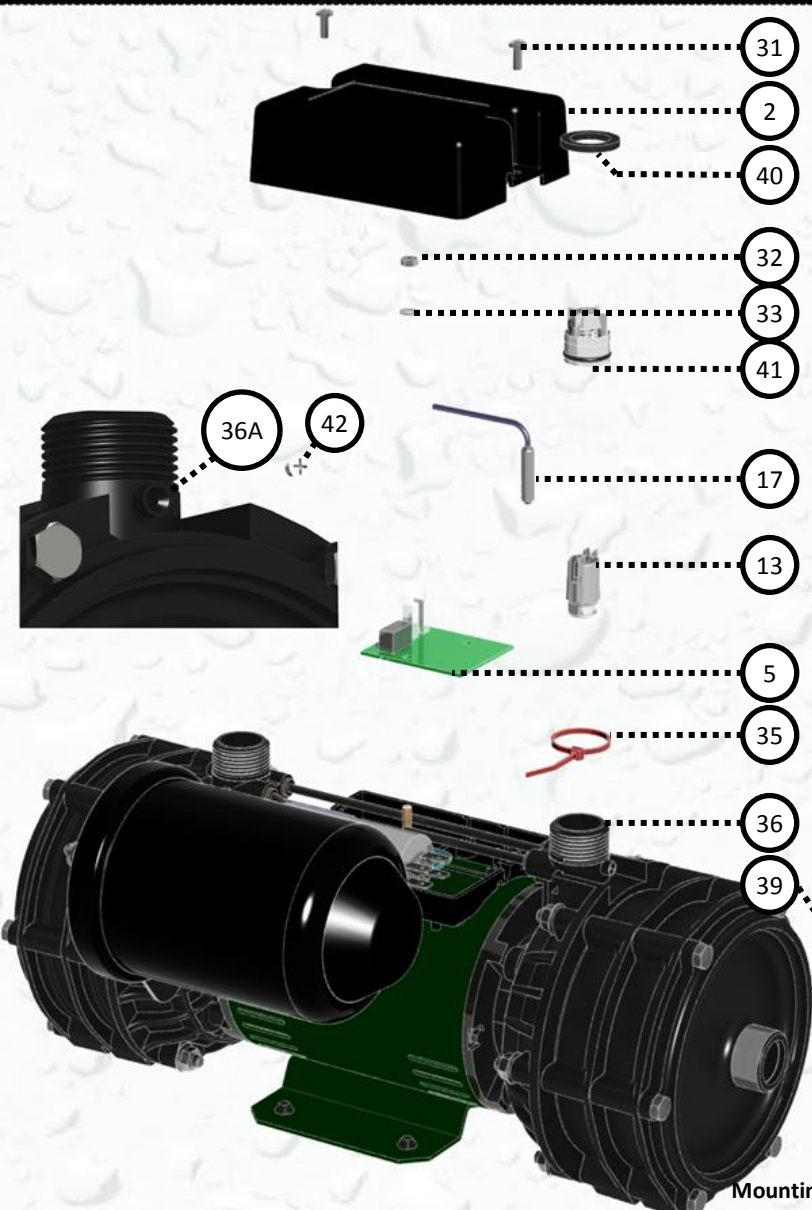

1. Remove Junction box (JB) lid screws (31) using PZ2 screwdriver and discard.
2. Remove JB lid (2) and retain.
3. Disconnect Hall Effect (HE) sensor lead (17 noting type)
4. Snip cable tie , noting colour that secures HE sensor to pump housing , note its orientation and remove. Discard both.
- RED IS HOT SIDE**
5. Repeat above steps for opposite pump side.
6. Disconnect mains and motor cables noting their orientation.
7. Remove M4 nut(32) and M4 washer(33) using 7mm deep socket.
8. Remove PCB interface (5) and carefully remove pressure transducer tube from carstick fitting in the outer(36), by pressing outer QR ring that secures the tube.
9. Fit new PCB interface and insert transducer tube into outer carstick ensuring it is cut to the same length with a vertical flat face.
10. Secure with M4 nut and washer and tighten to 1.95Nm +/- 0.15Nm
11. Insert new HE sensor (17) into OUTLET housing and secure with cable tie of CORRECT TYPE AND COLOUR. Snip excess cable tie off.
12. Repeat above steps for opposite pump side ENSURING CORRECT HE SENSOR AND COLOURED CABLE TIE. **BLUE IS COLD**
13. Reconnect both HE sensors and mains ,motor cables as per PCB diagram. Ensure cables are routed via junction box base cable slots.
- NOTE: RECONNECT PUMP AND TEST FOR SERVICEABILITY . IF OK THE NEXT STEPS ARE NOT REQUIRED. IF NOT OK FOLLOW INSTRUCTIONS WITH CARE AS THIS TASK IS ORDINARILY FACTORY PROVEN.**
14. Remove Non Return Valve (NRV) retaining screw PZ1 (42) FROM 36A aperture. Remove NRV (41) noticing its orientation using long nosed pliers and discard.
15. Remove Float(13) noticing its orientation.
16. Repeat above steps for opposite pump side.
17. Insert Float (13) into OUTLET in the same orientation as removed ensuring it engages with float guides and moves freely.
18. Insert NRV to stop position and fit NRV PZ1 screw into 36A. secured to 0.5 Nm max
- DO NOT OVER TIGHTEN OR USE SEALANT**
19. Refit JB lid checking no cables are trapped.
20. Re-secure JB lid screws to hand tight.
21. Reconnect couplers ensuring filter and rubber washers are seated correctly. Service is now complete and ready for test.

